



Queensland

*Transport Operations (Road Use Management) Act 1995*

# **Transport Operations (Road Use Management—Vehicle Registration) Regulation 2021**

**Current as at 1 October 2025**

© State of Queensland 2026



This work is licensed under a Creative Commons Attribution 4.0 International License.



Queensland

# Transport Operations (Road Use Management—Vehicle Registration) Regulation 2021

## Contents

---

		Page
<b>Part 1</b>	<b>Preliminary</b>	
<b>Division 1</b>	<b>Preliminary</b>	
1	Short title .....	13
2	Commencement .....	13
<b>Division 2</b>	<b>Interpretation and key concepts</b>	
3	Definitions .....	13
4	Meaning of exempt vehicle .....	13
5	Meaning of garage address .....	13
6	Meaning of registered operator .....	14
7	Meaning of registered vehicle and unregistered vehicle .....	14
8	Meaning of vehicle law .....	15
9	Complying with vehicle law .....	15
<b>Part 2</b>	<b>Requirements for using vehicles on roads</b>	
10	Vehicles used on roads must be registered except in particular circumstances .....	16
11	Driving or towing unregistered vehicle .....	16
12	Conditionally registered vehicles not to be used on road in contravention of conditional registration guideline conditions .....	18
13	Person may apply for authorisation to use unregistered vehicle on roads 18	
14	Deciding application .....	18
15	If application refused .....	19
16	If application granted .....	20
17	Permit to use intercepted unregistered vehicle on road .....	20
<b>Part 3</b>	<b>Vehicle registration</b>	

Contents

---

<b>Division 1</b>	<b>Registration</b>	
<b>Subdivision 1</b>	<b>Applying for registration</b>	
18	Vehicles eligible for registration . . . . .	21
19	Person may apply to register vehicle . . . . .	22
20	Requirements for registration application . . . . .	22
21	Deciding registration application . . . . .	24
22	Grounds on which chief executive may refuse registration application 25	
23	Grounds on which chief executive must refuse registration application 27	
24	Power to require further information not limited . . . . .	28
25	If registration application refused . . . . .	28
26	If registration application granted . . . . .	28
27	Registration certificates . . . . .	28
<b>Subdivision 2</b>	<b>Term of registration</b>	
28	Term . . . . .	30
29	When term of registration starts . . . . .	31
30	When term of registration expires . . . . .	31
<b>Division 2</b>	<b>Renewal of registration</b>	
31	Renewal notice . . . . .	32
32	Renewal application . . . . .	32
33	Requirements for renewal application . . . . .	33
34	Deciding renewal application . . . . .	34
35	Seasonal registration—deferral of day by which renewal application for seasonal heavy vehicle must be made . . . . .	34
36	When renewed term of registration expires . . . . .	35
37	When surcharge is payable for renewal . . . . .	35
38	Term of registration if overpayment or underpayment of registration- related amount and any surcharge . . . . .	36
39	Administrative fee for late payment if purported non-cash payment not received . . . . .	38
40	When renewal of registration takes effect and requirement to record expiry day . . . . .	38
<b>Division 3</b>	<b>Transferring registration</b>	
41	Definitions for division . . . . .	39
42	Acquirer of registered vehicle must apply for transfer . . . . .	39
43	Dealer must give notice of acquisition . . . . .	40
44	Application for transfer, or notice of disposal, by disposer of registered	

	vehicle . . . . .	41
45	Statement to be given if particular details of disposer can not be provided 42	
46	Chief executive may require acquirer to apply for transfer of registration 42	
47	Dealer from whom acquirer acquires vehicle must apply for transfer of registration . . . . .	42
48	Chief executive may update register on receiving application, notice or statement . . . . .	43
49	Transferring registration under legal process . . . . .	44
50	Chief executive may refuse to record transfer of registration . . .	46
51	If recording of transfer refused . . . . .	47
<b>Division 4</b>	<b>Cancelling registration</b>	
<b>Subdivision 1</b>	<b>Cancellation by application</b>	
52	Application by registered operator . . . . .	47
53	Application by person acting under authority of court to sell vehicle	48
54	Additional requirements for application under s 52 or 53 . . . . .	48
55	Application by local government . . . . .	49
56	Application by commissioner . . . . .	50
<b>Subdivision 2</b>	<b>Cancellation by chief executive</b>	
57	Equivalently registered vehicles . . . . .	50
58	Noncompliance with notice about defective or unsafe vehicle—Act, s 18 51	
59	Other grounds—Act, s 18 . . . . .	51
60	Cancellation of heavy vehicle's registration by court . . . . .	52
60A	Entities prescribed—Act, ss 19D and 19E . . . . .	53
<b>Subdivision 3</b>	<b>Cancellation</b>	
61	Cancelling registration . . . . .	53
62	When cancellation on application by vehicle's registered operator takes effect . . . . .	54
63	When cancellation by chief executive under s 57 takes effect . .	54
64	When cancellation on other grounds takes effect . . . . .	55
<b>Subdivision 4</b>	<b>Refunding or recovering registration fees</b>	
65	Partial refund of vehicle registration fee . . . . .	55
66	Chief executive may recover proportion of unpaid registration fee	56
<b>Division 5</b>	<b>Other provisions relating to registration</b>	
67	Vehicle inspections . . . . .	56
68	Registered operator must notify chief executive of particular changes	

Contents

---

	58	
69	Requirements relating to modification of vehicles . . . . .	58
70	Recording change of identifying number or other particulars for vehicle 59	
71	Reassessment of registration fee on recording of changed particulars 60	
72	Application of Act, s 56 . . . . .	61
<b>Part 4</b>	<b>When vehicle registration unnecessary</b>	
<b>Division 1</b>	<b>Unregistered vehicle permits</b>	
73	Application for permit . . . . .	61
74	Grant of permit . . . . .	62
75	If permit not granted . . . . .	62
76	Requirement to carry permit . . . . .	63
<b>Division 2</b>	<b>Dealer plates</b>	
<b>Subdivision 1</b>	<b>Preliminary</b>	
77	Designation of dealer plates . . . . .	63
<b>Subdivision 2</b>	<b>Registration</b>	
78	Registration application . . . . .	64
79	Deciding registration application . . . . .	64
80	If registration application refused . . . . .	65
81	If registration application granted . . . . .	65
82	Term of registration . . . . .	65
83	Registration not transferable . . . . .	66
<b>Subdivision 3</b>	<b>Renewing registration</b>	
84	Renewal notice . . . . .	66
85	Renewal application . . . . .	67
86	Requirements for renewal application . . . . .	67
87	Deciding renewal application . . . . .	67
88	If renewal application refused . . . . .	68
89	When renewed term of registration expires . . . . .	68
90	When surcharge is payable for renewal . . . . .	68
91	Term of registration if overpayment or underpayment of registration-related amount and any surcharge . . . . .	69
92	Administrative fee for late payment if purported non-cash payment not received . . . . .	71
93	When renewal of registration takes effect and requirement to record expiry day . . . . .	71

94	Return of dealer plate if registration not renewed . . . . .	72
<b>Subdivision 4</b>	<b>Using dealer plates</b>	
95	Definition for subdivision . . . . .	72
96	Use of unregistered vehicle with registered dealer plate attached	72
97	Registered dealer plate to be attached in same way as number plate	73
98	Using vehicles with registered dealer plates attached . . . . .	73
99	Attaching registered dealer plates, other than dealer (trailer trade) plates, to vehicles carrying loads . . . . .	75
100	Using vehicles with dealer (trailer trade) plates attached . . . . .	76
<b>Subdivision 5</b>	<b>Cancelling registration</b>	
101	Application by registered operator . . . . .	76
102	Cancellation because of ending of or material change in business	77
103	Cancellation on other grounds—Act, s 18 . . . . .	78
104	When cancellation takes effect . . . . .	79
105	Recovering proportion of registration amount . . . . .	79
<b>Subdivision 6</b>	<b>Miscellaneous</b>	
106	Application of Act, s 56 . . . . .	79
<b>Division 3</b>	<b>Vehicles temporarily in Queensland</b>	
107	Application of division . . . . .	79
108	Use of vehicle on road . . . . .	80
109	Production of proof of particular matters or left-hand drive permit if vehicle registered in foreign country . . . . .	81
<b>Division 4</b>	<b>Particular equivalently registered vehicles</b>	
110	Vehicle registered in another State in name of defence force member or eligible family member . . . . .	82
<b>Part 5</b>	<b>Register of vehicles and number plates</b>	
111	Chief executive must keep register . . . . .	83
112	Details for registered vehicles and registered dealer plates . . . . .	83
113	Notifiable information about written-off vehicles to be kept . . . . .	86
114	Details for personalised number plates to be kept . . . . .	86
115	Details for unregistered vehicle permits to be kept . . . . .	87
116	Information on register not conclusive of title to registered vehicle	87
<b>Part 6</b>	<b>Number plates</b>	
<b>Division 1</b>	<b>Number plates generally</b>	
117	Assigning registration numbers and giving number plates . . . . .	88
118	Position, visibility and legibility of number plates . . . . .	89
119	Position, visibility and legibility requirements not contravened in	

Contents

---

	particular circumstances . . . . .	91
120	When registered operator must attach number plates . . . . .	92
121	When number plate must not be attached to a vehicle . . . . .	93
122	Number plates not legible because damaged or dirty . . . . .	93
123	Damaged, destroyed, lost or stolen number plates . . . . .	94
123A	Waiving fee for particular number plates damaged, destroyed, lost or stolen in particular circumstances . . . . .	97
124	Copied number plates . . . . .	97
125	Chief executive may require exchange of number plates . . . . .	98
126	Chief executive may require return of number plates if term of registration expires . . . . .	100
127	Chief executive may require return of number plates for other reasons 100	
128	Who owns number plates . . . . .	102
<b>Division 2</b>	<b>Special edition number plates</b>	
129	Special edition number plates . . . . .	103
130	Application to replace number plate with special edition number plate 103	
<b>Division 3</b>	<b>National heavy vehicle number plates</b>	
131	Application to replace number plate with national heavy vehicle number plate . . . . .	104
<b>Division 4</b>	<b>Personalised number plates</b>	
132	Personalised number plates given on application or sale . . . . .	105
133	Using personalised number plates . . . . .	106
134	Attaching personalised number plates to vehicles . . . . .	106
135	Transferring personalised number plates . . . . .	107
136	Converting number plate to personalised number plate . . . . .	108
<b>Division 5</b>	<b>Customised number plates</b>	
137	Customising number plates . . . . .	109
138	Attaching customised number plates to vehicles . . . . .	110
<b>Division 6</b>	<b>Accessory plates</b>	
139	Applying for accessory plates for vehicles other than tow trucks . . . . .	111
140	Attaching accessory plates to vehicles other than tow trucks . . . . .	111
141	Applying for accessory plates for tow trucks . . . . .	112
142	Attaching accessory plates for tow trucks . . . . .	112
<b>Division 6A</b>	<b>Approval for modified number of number plates</b>	
142A	Application for approval to modify number of number plates . . . . .	113

<b>Part 7</b>	<b>Written-off vehicles</b>	
<b>Division 1</b>	<b>Classification and use of written-off vehicles</b>	
143	Vehicle assessed as total loss to be classified as statutory write-off or repairable write-off . . . . .	114
144	Offence to use written-off vehicle on road . . . . .	115
<b>Division 2</b>	<b>Information about written-off vehicles</b>	
<b>Subdivision 1</b>	<b>Interpretation</b>	
145	Definitions for division . . . . .	117
<b>Subdivision 2</b>	<b>Obligations to give information about written-off vehicles</b>	
146	Obligation of insurers to report written-off vehicles . . . . .	117
147	Obligation of self-insurers to report written-off vehicles . . . . .	118
148	Obligation of loss adjusters to report written-off vehicles . . . . .	118
149	Obligation of dealers and auctioneers to report written-off vehicles . . . . .	119
150	Obligation of auto parts dismantlers to report written-off vehicles . . . . .	120
151	Obligation of registered operators and owners of unregistered vehicles to give chief executive notifiable information for written-off vehicles . . . . .	121
152	Notifier may change notifiable information previously given . . . . .	122
153	Notifier may apply to correct error in notifiable information previously given . . . . .	122
154	Offence to give false or misleading notifiable information . . . . .	123
155	Requirement to notify chief executive of repair of written-off vehicle . . . . .	123
156	Requirement to give chief executive other information . . . . .	123
157	Notifiers' obligation to inform responsible persons for notifiable vehicles . . . . .	124
<b>Subdivision 3</b>	<b>Labels for written-off vehicles</b>	
158	Specifications for labels to be used by notifiers . . . . .	125
159	Notifiers' obligation to attach labels to written-off vehicles . . . . .	125
160	Chief executive must give label for written-off vehicle to person who gives notifiable information under s 151 . . . . .	126
161	Responsible person must attach label to written-off vehicle . . . . .	126
162	Offence to remove written-off vehicle label . . . . .	127
<b>Subdivision 4</b>	<b>Audits</b>	
163	Auditing of notifiers . . . . .	127
164	Identification of contravention in audit report . . . . .	127
<b>Division 3</b>	<b>Approvals for written-off vehicle inspections</b>	
165	Application for inspection approval . . . . .	128
166	Deciding application . . . . .	129

Contents

---

167	Notice of decision .....	130
168	Inspection approval prescribed for Act, ss 17B and 18 .....	130
<b>Division 4</b>	<b>Offences relating to written-off vehicle inspections</b>	
169	Only approved written-off vehicle examiner may perform written-off vehicle inspection .....	131
170	Only approved written-off vehicle nominee may supervise written-off vehicle inspection .....	131
171	Not complying with conditions of inspection approval .....	131
172	False or misleading written-off vehicle inspection report .....	131
173	Operating place as written-off vehicle inspection site .....	131
174	Performing written-off vehicle inspection at place other than written-off vehicle inspection site .....	132
175	Supervising written-off vehicle inspection at place other than written-off vehicle inspection site .....	132
176	False advertising or holding out .....	132
<b>Part 8</b>	<b>Measures for natural disasters and droughts</b>	
<b>Division 1</b>	<b>Natural disasters</b>	
177	Application of division .....	133
178	Definitions for division .....	133
179	When natural disaster relief measures may be relied on .....	134
180	Natural disaster relief notice .....	134
181	Reduced term of registration or renewal of registration .....	135
182	Exemption from surcharge for reduced term of registration or administrative fee for late payment .....	135
183	Seasonal registration—deferral of day by which renewal application must be made .....	135
<b>Division 2</b>	<b>Droughts</b>	
184	Application of division .....	135
185	Definitions for division .....	136
186	Meaning of eligible vehicle .....	136
187	Reduced term of registration or renewal of registration .....	138
188	Exemption from surcharge for reduced term of registration or from administrative fee for late payment .....	138
189	Supporting material must be given .....	138
190	Seasonal registration—deferral of day by which renewal application must be made .....	139
<b>Division 3</b>	<b>Transport of fodder for disaster or drought-affected primary producers</b>	
191	Transport of fodder by primary producer for another primary producer	

	139	
<b>Part 9</b>	<b>Requirements for particular applications and customer communications</b>	
<b>Division 1</b>	<b>Preliminary</b>	
192	Definitions for part . . . . .	140
<b>Division 2</b>	<b>Particular applications</b>	
193	Chief executive may publish notice about applications . . . . .	141
194	How applications must be made . . . . .	142
195	Chief executive may request further information . . . . .	143
<b>Division 3</b>	<b>Particular customer communications</b>	
196	Chief executive may publish notice about customer communications 144	
197	How customer communications must be given or made . . . . .	144
<b>Part 10</b>	<b>Use and release of information</b>	
<b>Division 1</b>	<b>Use of information from register</b>	
198	Definition for division . . . . .	145
199	Use of prescribed information for contacting registered operator about moving or removing vehicle . . . . .	145
200	Use of information for contacting registered operator about recovery of cost of damage . . . . .	146
<b>Division 2</b>	<b>Release of information from register</b>	
201	Definitions for division . . . . .	146
202	Giving extracts from register to eligible persons . . . . .	148
203	Public access providers may allow client users to obtain extracts from register . . . . .	150
204	Giving extracts from register to tolling entities . . . . .	151
205	Giving information to entities that maintain NEVDIS . . . . .	153
206	Information provider may give vehicle-related information . . . . .	153
207	Chief executive may give vehicle-related information to particular persons . . . . .	155
<b>Part 11</b>	<b>Offences and other matters relating to registration certificates, number plates and permits</b>	
208	References to registration certificate, number plate or permit . . .	156
209	Things that purport to be, but are not, registration certificates, number plates or permits . . . . .	157
210	Altering or defacing registration certificates, number plates or permits 157	
211	Using, or permitting use of, vehicle for which registration certificate, number plate or permit altered etc. . . . .	157

Contents

---

212	Requirement to remove unlawful registration item . . . . .	158
<b>Part 12</b>	<b>Review of decisions</b>	
213	Review of decisions not provided for under Act, ch 4 . . . . .	160
<b>Part 13</b>	<b>Miscellaneous</b>	
<b>Division 1</b>	<b>Approval of motorbikes as learner approved motorbikes</b>	
214	Definition for division . . . . .	161
215	Meaning of LAM test report . . . . .	161
216	Application for approval of motorbike as a learner approved motorbike 162	
217	Deciding application . . . . .	163
218	Chief executive must keep list of learner approved motorbikes .	164
<b>Division 2</b>	<b>Other provisions</b>	
219	Sale of unregistered vehicles by dealers . . . . .	165
<b>Part 14</b>	<b>Fees and related matters</b>	
<b>Division 1</b>	<b>Fees generally</b>	
220	Fees . . . . .	166
220A	Rounding of amounts expressed as numbers of fee units . . . . .	167
221	Charging categories . . . . .	167
<b>Division 2</b>	<b>Exemptions</b>	
222	Eligible person may apply for exemption from paying particular fees 168	
223	Registered operator for motorised mobility device may apply for exemption from paying transfer application fee . . . . .	170
224	Eligible prescribed service person may apply for exemption from particular fees . . . . .	170
225	Deciding applications . . . . .	171
226	Notification requirements for person granted exemption from paying particular fees . . . . .	171
227	Chief executive must give notice before reassessing fee for which exemption granted . . . . .	172
228	Reassessment of fee for which exemption granted . . . . .	173
<b>Division 2A</b>	<b>Recognised primary producers and nominated primary producers</b>	
228A	Meaning of recognised primary producer and nominated primary producer . . . . .	174
228B	Application to be a recognised primary producer . . . . .	175
228C	Deciding application to be a recognised primary producer . . . . .	175
228D	Application to nominate a recognised primary producer . . . . .	175
228E	Deciding application to nominate a recognised primary producer	176

228F	Notices and details recorded in the register .....	176
<b>Division 3</b>	<b>Concessional registration</b>	
<b>Subdivision 1</b>	<b>Applying for concessional registration</b>	
229	Eligible person may apply .....	177
230	Deciding application .....	177
231	Concessional registration fee for particular vehicles that have, or are proposed to have, 2 registered operators .....	178
231A	Working out amounts of concessional registration fees .....	178
<b>Subdivision 2</b>	<b>Eligibility requirements</b>	
232	Persons eligible for ambulance vehicles and particular vehicles mentioned in sch 5 .....	179
233	Recognised primary producers and primary producers .....	179
234	Holders of seniors cards .....	180
235	Holders of pensioner concession cards .....	181
236	Prescribed service persons .....	183
237	Special interest vehicles .....	184
238	When registered operator for concessionally registered vehicle stops being eligible for concessional registration .....	184
<b>Subdivision 3</b>	<b>Use of concessionally registered vehicles</b>	
239	Use of concessionally registered vehicles generally .....	184
240	Use of farm plate vehicle .....	185
241	Use of restricted primary production vehicles .....	186
242	Use of concessionally registered special interest vehicle for which condition imposed .....	187
<b>Subdivision 4</b>	<b>Notification requirements for, and reassessment of, concessional registration</b>	
243	Notification requirements for registered operators of concessionally registered vehicles .....	187
243A	Notification requirements for registered operators of relevant vehicles and nominated primary producers .....	188
244	Chief executive must give notice before reassessing registration fee 189	
245	Reassessment of registration fee .....	190
246	Notice of decision .....	190
<b>Part 15</b>	<b>Transitional provisions</b>	
<b>Division 1</b>	<b>Transitional provisions for SL No. 113 of 2021</b>	
247	Definition for part .....	191
248	Applications made before commencement .....	191

Contents

---

249	References to recorded expiry day . . . . .	193
250	Continuation of expired regulation, pt 9, div 1 and existing natural disaster relief notices . . . . .	193
251	Continuation of expired regulation, pt 9, div 2 and existing drought declarations . . . . .	194
252	Existing entitlements to review . . . . .	194
253	References to inspection approvals . . . . .	194
254	Continuation of register . . . . .	194
255	References to expired regulation . . . . .	195
256	Acts Interpretation Act 1954 not limited . . . . .	195
<b>Division 2</b>	<b>Transitional provision for Transport Legislation (Fee Unit Conversion and Registration Fees) Amendment Regulation 2022</b>	
257	Fees payable under relevant provisions for registration . . . . .	195
<b>Division 3</b>	<b>Transitional provision for Transport Operations (Road Use Management—Vehicle Registration) and Other Legislation Amendment Regulation 2023</b>	
258	Existing registered operators of heavy primary production vehicles	196
<b>Schedule 1</b>	<b>Exempt vehicles . . . . .</b>	<b>197</b>
<b>Schedule 2</b>	<b>Category 1 vehicle registration fees for 1 year . . . . .</b>	<b>199</b>
<b>Schedule 3</b>	<b>Category 2 vehicle registration fees for 1 year . . . . .</b>	<b>204</b>
<b>Schedule 4</b>	<b>Other fees . . . . .</b>	<b>214</b>
<b>Schedule 5</b>	<b>Vehicles for particular concessional registration fees . . . . .</b>	<b>221</b>
<b>Schedule 6</b>	<b>Local government areas for schedule 5, section 10 for vehicles used solely to carry on business of prospecting . . . . .</b>	<b>225</b>
<b>Schedule 7</b>	<b>Grounds for cancellation of vehicle’s registration . . . . .</b>	<b>227</b>
<b>Schedule 8</b>	<b>Dictionary . . . . .</b>	<b>231</b>

---

# Transport Operations (Road Use Management—Vehicle Registration) Regulation 2021

## Part 1 Preliminary

### Division 1 Preliminary

#### 1 Short title

This regulation may be cited as the *Transport Operations (Road Use Management—Vehicle Registration) Regulation 2021*.

#### 2 Commencement

This regulation commences on 1 September 2021.

### Division 2 Interpretation and key concepts

#### 3 Definitions

The dictionary in schedule 8 defines particular words used in this regulation.

#### 4 Meaning of *exempt vehicle*

A vehicle mentioned in schedule 1 is an *exempt vehicle*.

#### 5 Meaning of *garage address*

- (1) In this regulation, the *garage address* of a vehicle that is normally kept on a road or road-related area when not in use is—

[s 6]

---

- (a) if there is only 1 registered operator of the vehicle—the address of the registered operator; or
  - (b) if there is more than 1 registered operator of the vehicle and the address of 1 or more of the registered operators is in Queensland—the address of the registered operator in Queensland closest to the road or road-related area where the vehicle is normally kept; or
  - (c) if there is more than 1 registered operator of the vehicle and the address of each registered operator is outside Queensland—the suburb and road, or address of the road-related area, where the vehicle is normally kept.
- (2) The **garage address** of a vehicle that is normally kept at a place other than a road or road-related area when not in use is the place where the vehicle is normally kept.

## 6 Meaning of **registered operator**

- (1) In this regulation, **registered operator**—
- (a) of a vehicle—does not include a person in whose name the vehicle is registered under a corresponding law; and
  - (b) for a dealer plate—is the person in whose name the dealer plate is currently registered.
- (2) To remove any doubt, it is declared that a person in whose name a dealer plate is equivalently registered is not the **registered operator** for the dealer plate for this regulation.

## 7 Meaning of **registered vehicle** and **unregistered vehicle**

- (1) A vehicle is a **registered vehicle** if—
- (a) the vehicle is registered under this regulation in a person's name; and
  - (b) the term of the vehicle's registration has not expired under section 30.
- (2) A vehicle is an **unregistered vehicle** if it is not—
- (a) a registered vehicle; or

- 
- (b) a vehicle that is equivalently registered.

## 8 Meaning of *vehicle law*

A *vehicle law*, in relation to a vehicle, is—

- (a) if the vehicle is a heavy vehicle—any of the following under the Heavy Vehicle National Law (Queensland)—
- (i) the heavy vehicle standards;
  - (ii) the mass requirements;
  - (iii) the dimension requirements; or
- (b) otherwise—the light vehicle standards under the *Transport Operations (Road Use Management—Vehicle Standards and Safety) Regulation 2021*.

## 9 Complying with vehicle law

- (1) A vehicle is taken to comply with a vehicle law if the vehicle complies with the requirements of the law, other than a requirement it is not required to comply with because of—
- (a) an exemption under the Heavy Vehicle National Law (Queensland); or
  - (b) a safe movement approval under the *Transport Operations (Road Use Management—Vehicle Standards and Safety) Regulation 2021*.
- (2) The chief executive may accept any of the following as evidence a vehicle complies with a vehicle law—
- (a) a plate attached to the vehicle under the vehicle law;
  - (b) a written statement from the vehicle’s manufacturer stating the vehicle complies with the vehicle law;
  - (c) an entry for the vehicle in the RAV.
- (3) In the absence of evidence mentioned in subsection (2), the chief executive may, on inspecting the vehicle and being satisfied it complies with the vehicle law, give a certificate to that effect.

## **Part 2**                      **Requirements for using vehicles on roads**

### **10**     **Vehicles used on roads must be registered except in particular circumstances**

- (1) A person must not use, or permit to be used, a vehicle on a road that is not a registered vehicle.

Maximum penalty—80 penalty units.

- (2) However, subsection (1) does not apply if the vehicle is—

- (a) an exempt vehicle; or
- (b) being driven or towed under section 11; or
- (c) being used under an authorisation granted under section 14; or
- (d) being used under a permit granted under section 17; or
- (e) being brought to the chief executive for an inspection under section 67; or
- (f) being used under an unregistered vehicle permit; or
- (g) being used with a registered dealer plate attached to it under section 96; or
- (h) being used under section 108 or 110.

### **11**     **Driving or towing unregistered vehicle**

- (1) A person may drive or tow an unregistered vehicle on a road to any of the places mentioned in subsection (3), or for the testing mentioned in subsection (4), if the driving or towing is necessary for, or reasonably connected with, registering the vehicle under this regulation.

- (2) Also, if the unregistered vehicle is required to be insured under the *Motor Accident Insurance Act 1994*, the person may drive or tow the vehicle under subsection (1) only if—

- 
- (a) a current certificate of insurance has been issued for the vehicle; and
  - (b) the certificate of insurance is carried—
    - (i) for a trailer—in the motor vehicle towing the trailer; or
    - (ii) for another vehicle—in the vehicle.
- (3) For subsection (1), the places are as follows—
- (a) an AIS, or a departmental inspection site, if the vehicle is driven or towed to the AIS or site for inspection for the purpose of obtaining an inspection certificate for the vehicle;
  - (b) a written-off vehicle inspection site, if the vehicle is—
    - (i) recorded in the register as a repairable write-off; and
    - (ii) driven or towed to the site for the purpose of obtaining a written-off vehicle inspection report;
  - (c) the vehicle’s garage address, if an inspection certificate is in effect for the vehicle;
  - (d) a departmental service centre, if the vehicle is driven or towed to the centre to register the vehicle;
  - (e) another place, if the chief executive requires the vehicle to be taken to the place.

*Examples for paragraph (e)—*

- a place for inspecting by the Queensland Police Service
  - a place for having an identifying number stamped
  - a place for obtaining a gas compliance document
  - a weighbridge for obtaining a measurement ticket
- (4) Also, for subsection (1), the testing is any testing necessary to confirm the safe operation of the vehicle as part of an inspection mentioned in subsection (3)(a).

[s 12]

---

**12 Conditionally registered vehicles not to be used on road in contravention of conditional registration guideline conditions**

A person must not permit a conditionally registered vehicle to be used on a road unless the conditions for the vehicle stated in the conditional registration guideline allow the vehicle to be used on the road.

Maximum penalty—30 penalty units.

**13 Person may apply for authorisation to use unregistered vehicle on roads**

- (1) A person may apply to the chief executive for an authorisation to use either of the following on a road—
  - (a) a particular unregistered vehicle;
  - (b) a class of unregistered vehicle.

*Note—*

See part 9, division 2 for requirements for particular applications.

- (2) The application may be made even if the unregistered vehicle or class of unregistered vehicle does not comply with a vehicle law applying to the vehicle or class.
- (3) However, a person may not make an application under subsection (1) in relation to an unregistered heavy vehicle, or a class of unregistered vehicle to the extent the class includes the heavy vehicle, if the vehicle does not comply with a vehicle law.

**14 Deciding application**

- (1) The chief executive must, after considering an application made under section 13—
  - (a) refuse the authorisation; or
  - (b) grant the authorisation, with or without conditions.
- (2) The chief executive may grant the authorisation only if the chief executive is satisfied the use of the unregistered vehicle

or class of unregistered vehicle on the road would not adversely affect road safety or inconvenience other road users.

- (3) Before granting, or as a condition of, the authorisation, the chief executive may require the applicant to pay the chief executive's actual or estimated costs of any of the following the chief executive considers necessary in relation to allowing the unregistered vehicle or class of unregistered vehicle to be used on the road under the authorisation—
  - (a) assessing the vehicle's route and preparing the relevant plans and estimates;
  - (b) preparing, strengthening, repairing, replacing or reconstructing road transport infrastructure on the vehicle's route;
  - (c) ensuring compliance with a condition or proposed condition of the authorisation.
- (4) Subsection (3) does not apply in relation to an authorisation to use either of the following on a road—
  - (a) an unregistered vehicle that is a heavy vehicle;
  - (b) a class of unregistered vehicle to the extent the class includes a heavy vehicle.

## **15 If application refused**

- (1) If the chief executive decides to refuse the authorisation, the chief executive must give the applicant written notice of the refusal.
- (2) The notice must state—
  - (a) the decision to refuse; and
  - (b) the reasons for the refusal; and
  - (c) that the decision may be reviewed under section 213.

[s 16]

---

## **16 If application granted**

- (1) If the chief executive decides to grant the authorisation, the chief executive must give the applicant a written authorisation.
- (2) The authorisation must state the following particulars—
  - (a) the unregistered vehicle or class of unregistered vehicle to which the authorisation applies;
  - (b) the road on which the vehicle or class of vehicle may be used under the authorisation;
  - (c) the term, of not longer than 5 years, for which the authorisation is granted;
  - (d) the conditions, if any, on which the authorisation is granted.

## **17 Permit to use intercepted unregistered vehicle on road**

- (1) This section applies if an authorised officer—
  - (a) finds either of the following on a road—
    - (i) a stationary unregistered vehicle;
    - (ii) an unregistered vehicle that has been stopped under section 31 or 32 of the Act, the *Police Powers and Responsibilities Act 2000* or the Heavy Vehicle National Law (Queensland); and
  - (b) does either of the following in relation to the vehicle—
    - (i) gives an infringement notice or notice to appear for a contravention of section 10;
    - (ii) completes a report for dealing with a contravention of section 10 at a later time.
- (2) The authorised officer may grant a permit authorising the use of the vehicle on a road to move it to a stated place.
- (3) The permit must—
  - (a) be in the approved form; and

- 
- (b) state the term, of not longer than 24 hours, for which it is granted; and
  - (c) state the conditions, if any, on which it is granted; and
  - (d) state—
    - (i) if subsection (1)(b)(i) applies—the number of the infringement notice or notice to appear; or
    - (ii) if subsection (1)(b)(ii) applies—that the contravention of section 10 is to be dealt with at a later time either by giving an infringement notice or notice to appear or by taking a proceeding by complaint and summons under the *Justices Act 1886*.
- (4) In this section—

*infringement notice* means an infringement notice under the *State Penalties Enforcement Act 1999*.

*notice to appear* means a notice to appear under the *Police Powers and Responsibilities Act 2000*.

## Part 3 Vehicle registration

### Division 1 Registration

#### Subdivision 1 Applying for registration

##### 18 Vehicles eligible for registration

- (1) A vehicle is eligible for registration if—
  - (a) the vehicle complies with the vehicle laws applying to the vehicle; and
  - (b) the vehicle’s garage address is in Queensland.

[s 19]

---

- (2) Also, a vehicle that does not comply with a vehicle law applying to the vehicle is eligible for registration if the conditional registration guideline or a heavy vehicle standards exemption applies to the vehicle.

## **19 Person may apply to register vehicle**

- (1) A person may apply to the chief executive to register a vehicle eligible for registration under section 18 in the person's name.

*Note—*

See part 9, division 2 for requirements for particular applications.

- (2) However, if the vehicle is a category 2 vehicle, the person may apply only if the person is—
  - (a) a corporation; or
  - (b) an individual who is at least 18.

## **20 Requirements for registration application**

- (1) A registration application for a vehicle must state—
  - (a) the term of registration applied for; and
  - (b) if section 18(2) applies to the vehicle—the type of conditional registration applied for.
- (2) The registration application must be accompanied by the following—
  - (a) the registration fee for the vehicle;
  - (b) the following fees stated in schedule 4—
    - (i) the plate fee stated in schedule 4, part 1 or 2 for the number plates for the vehicle;
    - (ii) if the term of registration applied for is less than 1 year—the surcharge stated in schedule 4, part 3 for processing the application;
    - (iii) if the application is for a type of conditional registration—the registration administration fee stated in schedule 4, part 3 for the type;

- 
- (iv) if the vehicle is a category 2 vehicle, other than a trailer, and subparagraph (iii) does not apply—the registration administration fee stated in schedule 4, part 3 for the vehicle;
  - (v) if the vehicle is a category 1 vehicle, other than a trailer, and subparagraph (iii) does not apply—the traffic improvement fee stated in schedule 4, part 3 for the vehicle;
  - (c) an insurance certificate required under the *Motor Accident Insurance Act 1994* for the vehicle for the proposed term of registration or the insurance premium payable under that Act for the certificate;
  - (d) if the vehicle is a COI vehicle under the *Transport Operations (Road Use Management—Vehicle Standards and Safety) Regulation 2021* and the vehicle’s owner will be, if the registration application is granted, required to ensure a certificate of inspection is in effect for the vehicle under that regulation—prescribed evidence that a certificate of inspection is in effect for the vehicle;
  - (e) if paragraph (d) does not apply to the vehicle—prescribed evidence that an inspection certificate is in effect for the vehicle, unless—
    - (i) the vehicle is a motorised mobility device; or
    - (ii) both of the following apply—
      - (A) the vehicle has never previously been registered in Queensland, another State or a foreign country;
      - (B) when the registration application is made, the vehicle’s odometer displays a distance of 500km or less; or
    - (iii) the vehicle is a vehicle mentioned in the *Transport Operations (Road Use Management—Vehicle Standards and Safety) Regulation 2021*, section 69; or

[s 21]

---

- (iv) the application is for registration of the vehicle in the name of a dealer for the purpose of selling the vehicle; or
  - (v) the proposed garage address for the vehicle is in an exempt area for the vehicle under the *Transport Operations (Road Use Management—Vehicle Standards and Safety) Regulation 2021*; or
  - (vi) the vehicle is a light vehicle that will be maintained under an alternative compliance scheme approved by the chief executive;
- (f) vehicle registration duty, if any, imposed on the application under the *Duties Act 2001*, chapter 9;
  - (g) if there is a gas system in the vehicle—a gas compliance document for the system;
  - (h) if the applicant is relying on section 187 or 188 in relation to the registration—the supporting material required under section 189.

*Notes—*

- 1 Under sections 19J and 19L of the Act, an application for the registration of a vehicle must be accompanied by a statutory declaration in particular circumstances.
- 2 See part 9, division 2 for requirements for particular applications.

## **21 Deciding registration application**

- (1) The chief executive must, after considering a registration application for a vehicle—
  - (a) refuse the application under section 22 or 23; or
  - (b) grant the application.
- (2) Subsection (3) applies if the chief executive grants an application to register a conditionally registrable vehicle.
- (3) The chief executive must impose 1 of the following conditions, as stated in the guideline or exemption for the vehicle, on the registration of the vehicle—

- 
- (a) a condition restricting the use of the vehicle to a stated area or stated purpose (a ***limited access registration***);
  - (b) a condition limiting the distance, for each stated zone, that a vehicle may travel on a single journey in the zone (a ***zone access registration***);
  - (c) a condition, other than a condition mentioned in paragraph (a) or (b), for the vehicle (an ***unrestricted access registration***).
- (4) The registration of a vehicle to which a condition applies under subsection (3) is a ***conditional registration***.

## **22 Grounds on which chief executive may refuse registration application**

- (1) The chief executive may refuse a registration application for a vehicle if the chief executive reasonably believes—
- (a) information given in the application is false or misleading; or
  - (b) the vehicle's chassis number or VIN is the same as the chassis number or VIN of a vehicle recorded in the register, or in a register kept under a corresponding law to this regulation, as a statutory write-off; or
  - (c) the vehicle's chassis number or VIN is the same as the chassis number or VIN of a vehicle—
    - (i) that is recorded in the register as a repairable write-off; and
    - (ii) for which there is no written-off vehicle inspection report; or
  - (d) the vehicle's chassis number or VIN is the same as the chassis number or VIN of a vehicle recorded in a register kept under a corresponding law to this regulation as a repairable write-off, unless there is—
    - (i) a written-off vehicle inspection report for the vehicle; or

[s 22]

---

- (ii) a report for the vehicle that is, under the corresponding law, equivalent to a written-off vehicle inspection report; or
- (e) a person has committed an offence by giving, or purporting to give—
  - (i) a written-off vehicle inspection report for the vehicle under this regulation; or
  - (ii) a report that is equivalent to a written-off vehicle inspection report for the vehicle under a corresponding law to this regulation; or
- (f) an approved examiner has approved an inspection certificate for the vehicle in contravention of the *Transport Operations (Road Use Management—Vehicle Standards and Safety) Regulation 2021*, section 85(3); or
- (g) there are unpaid fines or penalties resulting from the use of the vehicle in Queensland or another State; or
- (h) the vehicle has been registered in another State and—
  - (i) the registration has been suspended or cancelled for a reason other than its expiry; and
  - (ii) the reason for the cancellation or suspension still exists; or
- (i) all of the following apply—
  - (i) the vehicle is a heavy vehicle;
  - (ii) a court has made an order against a person under the Heavy Vehicle National Law (Queensland), section 598(2) cancelling the registration of the vehicle;
  - (iii) the court has also, under section 598(3) of that Law, made an order that the person, or an associate of the person, is disqualified from applying for the registration of the vehicle for a stated period;
  - (iv) the applicant for registration is, under the order mentioned in subparagraph (iii), currently

disqualified from applying for registration of the vehicle.

- (2) Also, the chief executive may refuse a registration application for a vehicle if—
- (a) all or part of the vehicle is subject to the *Consumer Goods (Motor Vehicles With Affected Takata Airbag Inflators and Specified Spare Parts) Recall Notice 2018* (Cwlth) (the **recall notice**); and
  - (b) the ACCC gives the chief executive written advice that—
    - (i) the supplier of the vehicle is considered to have complied with its obligations to replace affected airbag inflators under the recall notice; and
    - (ii) an affected airbag inflator fitted within the vehicle has not been replaced in compliance with the recall notice; and
  - (c) the chief executive reasonably believes that each affected airbag inflator fitted within the vehicle has not been replaced in compliance with the recall notice.

## **23 Grounds on which chief executive must refuse registration application**

The chief executive must refuse a registration application for a vehicle if—

- (a) the vehicle is not eligible to be registered under section 18; or
- (b) the chief executive reasonably believes all or part of the vehicle is or may be stolen; or
- (c) for a conditionally registrable vehicle—
  - (i) if the vehicle is a heavy vehicle—the chief executive is not satisfied the vehicle complies with a heavy vehicle standards exemption; or

[s 24]

---

- (ii) if the conditional registration guideline applies to the vehicle—the chief executive is not satisfied the vehicle complies with the guideline.

## **24 Power to require further information not limited**

Sections 21 and 23 are subject to section 195.

## **25 If registration application refused**

- (1) If the chief executive decides to refuse a registration application for a vehicle, the chief executive must give the applicant written notice of the refusal.
- (2) The notice must state—
  - (a) the decision to refuse; and
  - (b) the reasons for the refusal; and
  - (c) if the decision to refuse may be reviewed under section 213—that the decision may be reviewed under that section.
- (3) The decision may not be reviewed under section 213 if the vehicle’s chassis number or VIN is the same as the chassis number or VIN of a vehicle recorded in the register, or in a register kept under a corresponding law to this regulation, as a statutory write-off.

## **26 If registration application granted**

If the chief executive decides to grant a registration application for a vehicle, the chief executive must record in the register the details required for the vehicle under section 112.

## **27 Registration certificates**

- (1) If the chief executive records details for a vehicle under section 26, the chief executive must make a registration

---

certificate for the vehicle available to the registered operator of the vehicle.

- (2) The registration certificate must include each of the following details for the vehicle—
  - (a) the registered operator's name;
  - (b) the day the registration expires;
  - (c) the vehicle's registration number;
  - (d) the make of the vehicle;
  - (e) if the vehicle has a VIN—the VIN;
  - (f) if the vehicle does not have a VIN—the vehicle's chassis number or engine number;
  - (g) the vehicle's GVM;
  - (h) if the vehicle has a GCM—the GCM;
  - (i) if the vehicle is a heavy vehicle—the charging code for the vehicle;
  - (j) if the vehicle is a conditionally registered heavy vehicle—
    - (i) the conditions stated in the heavy vehicle standards exemption that apply to the vehicle; and
    - (ii) a code, for example a letter of the alphabet, for each of the conditions;
  - (k) if the vehicle is a conditionally registered vehicle, other than a heavy vehicle—
    - (i) the conditions for use applying to the vehicle stated in the conditional registration guideline; and
    - (ii) a separate code, for example a letter of the alphabet, for each of the conditions.
- (3) The certificate of registration may include other information required to be kept in the register for the vehicle under section 112.
- (4) In this section—

[s 28]

---

*charging code*, for a heavy vehicle, means the code, assigned by the chief executive, to the category of vehicle mentioned in schedule 3 to which the vehicle belongs.

## Subdivision 2 Term of registration

### 28 Term

- (1) A vehicle may be registered for a term of—
  - (a) 1 year; or
  - (b) 6 months.
- (2) Also, a vehicle may be registered for a term of 3 months if—
  - (a) the vehicle is a category 2 vehicle; or
  - (b) the vehicle is used to provide a taxi service or a booked hire service within the meaning of the *Transport Operations (Passenger Transport) Act 1994*; or
  - (c) both of the following apply—
    - (i) the registered operator of the vehicle is a dealer;
    - (ii) the vehicle's purpose of use is recorded in the register or nominated in a registration application as dealer purposes; or
  - (d) the applicant for registration of the vehicle agrees to the matters mentioned in subsection (5).
- (3) In addition, a vehicle may be registered for a term of 1 month if the applicant for registration of the vehicle agrees to the matters mentioned in subsection (5).
- (4) Also, the chief executive may approve another term if—
  - (a) the applicant for registration of the vehicle asks to register the vehicle for a stated term of up to 14 months; and
  - (b) the chief executive considers that, because of extraordinary circumstances, it would be reasonable to register the vehicle for the stated term.

*Note—*

See part 9, division 2 for requirements for particular applications.

- (5) For subsections (2)(d) and (3), the matters are—
- (a) any amounts payable by the applicant under this regulation in relation to the registration will be paid under a direct debit arrangement; and
  - (b) the applicant will receive all communication in relation to the registration electronically.

## **29 When term of registration starts**

The term of registration of a vehicle starts—

- (a) if an exemption under section 225 has been granted for the vehicle—on the day a certificate of registration for the vehicle is made available under section 27; or
- (b) otherwise—on the day the chief executive gives the applicant a receipt for payment of the fees payable under this regulation for the registration.

## **30 When term of registration expires**

The term of registration for a vehicle expires—

- (a) if the registration is cancelled before the recorded expiry day for the registration—when the cancellation takes effect; or
- (b) otherwise—at the end of the recorded expiry day for the registration.

## **Division 2                      Renewal of registration**

### **31            Renewal notice**

(1) The chief executive may, before the recorded expiry day for a vehicle's registration, give a notice about renewing the registration to—

- (a) if the registered operator of the vehicle has given the chief executive a direction to send the notice to another person—the other person; or

*Note—*

See part 9, division 3 for requirements for particular customer communications.

- (b) otherwise—the registered operator of the vehicle.

(2) The notice must state—

- (a) the recorded expiry day for the registration; and
- (b) that if the registration is not renewed on or before the recorded expiry day, the registration expires; and
- (c) that if the registration is renewed after the recorded expiry day, the renewal application for the registration must be accompanied by the administrative fee stated in schedule 4, part 3 for the renewal.

(3) If the chief executive does not send, or the registered operator does not receive, the notice, the non-receipt of the notice by the registered operator does not affect—

- (a) the expiry of the registration; or
- (b) if the registered operator intends to use the vehicle on a road after the recorded expiry day—the registered operator's obligation to renew the registration before the registration expires.

### **32            Renewal application**

(1) A person may apply to the chief executive for renewal of a vehicle's registration.

*Note—*

See part 9, division 2 for requirements for particular applications.

- (2) The application must be made on or before the day that is 3 months after the recorded expiry day for the registration.
- (3) However, if the vehicle is a prescribed heavy vehicle for which a deferral for a period has been given by the chief executive under section 35, 183 or 190, the application must be made on or before the last day of the period.
- (4) Also, the chief executive may accept a renewal application for a vehicle's registration made other than when required under subsection (2) or (3), if the chief executive considers it reasonable in the circumstances to do so.
- (5) Nothing in this section has the effect of retrospectively registering a vehicle.

### **33 Requirements for renewal application**

- (1) A person's renewal application for a vehicle must be accompanied by the following—
  - (a) the registration fee for the vehicle;
  - (b) the following fees stated in schedule 4, part 3—
    - (i) if the application is for the renewal of conditional registration—the registration administration fee for the conditional registration;
    - (ii) if the vehicle is a category 2 vehicle, other than a trailer, and subparagraph (i) does not apply—the registration administration fee for the vehicle;
    - (iii) if the vehicle is a category 1 vehicle, other than a trailer, and subparagraph (i) does not apply—the traffic improvement fee for the vehicle;
    - (iv) if the application is made after the registration expires—the administrative fee for the renewal;

[s 34]

---

- (v) if the applicant is required to pay a surcharge for processing the application under section 37—the surcharge;
  - (c) an insurance certificate required under the *Motor Accident Insurance Act 1994* for the vehicle for the proposed term of registration or the insurance premium payable under that Act for the certificate;
  - (d) if the vehicle is a COI vehicle under the *Transport Operations (Road Use Management—Vehicle Standards and Safety) Regulation 2021* whose owner will be, if the renewal application is granted, required to ensure a certificate of inspection is in effect for the vehicle under that regulation—prescribed evidence that a certificate of inspection is in effect for the vehicle;
  - (e) if the applicant is relying on section 187 or 188 in relation to the renewal—the supporting material required under section 189.
- (2) The renewal application must state the term of registration applied for.

### **34 Deciding renewal application**

- (1) The chief executive must, after considering a renewal application for a vehicle—
- (a) refuse the application; or
  - (b) grant the application.
- (2) Sections 21, 22 and 23 apply to a renewal application for a vehicle as if a reference in those sections to a registration application for a vehicle were a reference to the renewal application for the vehicle.

### **35 Seasonal registration—deferral of day by which renewal application for seasonal heavy vehicle must be made**

- (1) This section applies in relation to a seasonal heavy vehicle if the current term of the vehicle’s registration is 3 or 6 months.

- (2) The chief executive may, on or before the recorded expiry day for the seasonal heavy vehicle's registration, defer the day by which a renewal application for the vehicle must be made for a period of not longer than a year.
- (3) This section does not limit a deferral of the seasonal heavy vehicle's renewal of registration under section 183 or 190.

### **36 When renewed term of registration expires**

- (1) The day a renewed term of a vehicle's registration expires must be worked out as if the term had started on—
  - (a) if the registration is renewed during a deferral period mentioned in section 35(2), 183(2) or 190(2) for the renewal—the day the registration was renewed; or
  - (b) otherwise—the day after the recorded expiry day for the registration.
- (2) Nothing in subsection (1) has the effect of retrospectively registering a vehicle.

### **37 When surcharge is payable for renewal**

- (1) This section applies to a renewal application for a vehicle for a term of less than 1 year.
- (2) Also, this section applies if—
  - (a) a renewal application for a vehicle is accompanied by an insurance certificate mentioned in section 33(1)(c); and
  - (b) despite the requirement under section 33(1), the applicant underpays the registration-related amount for the renewal by more than \$1 below what the registration-related amount would be if the registration fee payable under section 33(1)(a) for the renewal were for 1 year's registration.
- (3) In addition, this section applies if—

[s 38]

---

- (a) a renewal application for a vehicle is not accompanied by an insurance certificate mentioned in section 33(1)(c); and
- (b) the applicant underpays the registration-related amount for the renewal by more than \$1 below what the registration-related amount would be if—
  - (i) the registration fee payable under section 33(1)(a) for the renewal was for 1 year’s registration; and
  - (ii) the CTP insurance premium payable under section 33(1)(c) in relation to the renewal was the lowest premium set by a CTP insurer for a CTP insurance policy covering 1 year’s registration.
- (4) The applicant must pay the surcharge stated in schedule 4, part 3 for processing the renewal application.

**38 Term of registration if overpayment or underpayment of registration-related amount and any surcharge**

- (1) This section applies if—
  - (a) a renewal application for a vehicle is not accompanied by an insurance certificate mentioned in section 33(1)(c); and
  - (b) the applicant overpays or underpays the total of the following amounts—
    - (i) the registration-related amount for the renewal;
    - (ii) a surcharge payable for processing the application under section 33(1)(b)(v) or 37(4).
- (2) The chief executive may renew the registration for a term adjusted in proportion to the amount paid after deducting—
  - (a) the surcharge; and
  - (b) if an administrative fee stated in schedule 4, part 3 is payable for the renewal—the administrative fee.
- (3) However, if the amount paid is more than \$1 below what the total of the registration-related amount and the surcharge

---

would be if a CTP insurance premium, payable under section 33(1)(c) in relation to the renewal for the minimum available term of registration for the vehicle, was the lowest premium set by a CTP insurer for a CTP insurance policy, the chief executive—

- (a) must not renew the vehicle's registration under subsection (2); and
  - (b) must refund the amount paid to the applicant.
- (4) Also, if the amount paid is, on a proportionate basis, more than the registration-related amount for the renewal that would be payable if the registration were to be renewed for 14 months, the chief executive—
- (a) may only renew the registration for 14 months; and
  - (b) must refund the difference between the amount paid and the registration-related amount for the 14-month renewal to the applicant.
- (5) If the term of registration would, other than for this subsection, not be a whole number of days, the chief executive must—
- (a) round the term down to the nearest whole day; and
  - (b) credit the difference between the amount paid and the total of the registration-related amount for the renewal and any surcharge payable for the renewal to the applicant.
- (6) The chief executive must—
- (a) if subsection (3) applies—notify the applicant that the amount paid is being refunded because it is below the minimum amount required to enable renewal of registration; or
  - (b) otherwise, make available to the applicant a notice stating—
    - (i) the term of registration for the vehicle; and
    - (ii) if subsection (4) or (5) applies—the reason for any amount refunded or credited to the applicant.

[s 39]

---

(7) In this section—

*minimum available term of registration*, for a vehicle, means—

- (a) if the vehicle is a category 2 vehicle—3 months; or
- (b) otherwise—6 months.

### **39 Administrative fee for late payment if purported non-cash payment not received**

- (1) This section applies in relation to a renewal application for a vehicle if—
  - (a) before the recorded expiry day for the vehicle’s registration, all or part of the total amount payable for the renewal is purportedly paid using a payment method other than a cash payment; and
  - (b) the total amount payable in relation to the renewal is not received by the chief executive on or before the recorded expiry day; and
  - (c) after the recorded expiry day, all, or the remainder of, the total amount payable is paid to the chief executive.
- (2) The applicant for renewal must pay the administrative fee stated in schedule 4, part 3 for the renewal.

### **40 When renewal of registration takes effect and requirement to record expiry day**

- (1) The renewal of a vehicle’s registration takes effect—
  - (a) if all transactions relating to the renewal are completed on or before the recorded expiry day for the registration—immediately after the expiry of the term of registration being renewed; or
  - (b) otherwise—on the completion of all transactions relating to the renewal.

- (2) The chief executive must, on the completion of all transactions relating to the renewal, record in the register the day the renewed term of registration expires.

## Division 3                      Transferring registration

### 41                      Definitions for division

In this division—

*acquirer*, of a registered vehicle, means a person who buys or otherwise acquires the vehicle.

*acquisition*, of a registered vehicle, means the purchase or other lawful acquisition of the vehicle.

*disposal*, of a vehicle, see the *Transport Operations (Road Use Management—Vehicle Standards and Safety) Regulation 2021*, schedule 4.

*disposal notice* see section 44(1)(b).

*disposer*, of a registered vehicle, means a person who sells or otherwise disposes of the vehicle.

### 42                      Acquirer of registered vehicle must apply for transfer

- (1) This section applies to an acquirer of a registered vehicle, other than—
- (a) a dealer; or
  - (b) an acquirer of a vehicle from a dealer for which section 47 applies; or
  - (c) an acquirer of a vehicle to whom section 49(1) applies.
- (2) The acquirer must—
- (a) apply to the chief executive to transfer the vehicle's registration to the acquirer; and
  - (b) ensure the application is made within 14 days after the acquisition, unless the acquirer has a reasonable excuse.

[s 43]

---

Maximum penalty—16 penalty units.

*Note—*

See part 9, division 2 for requirements for particular applications.

- (3) The application must be accompanied by the following—
- (a) the fee stated in schedule 4, part 5 for the application;
  - (b) if an amount relating to the vehicle’s registration is payable, or has become payable because of the acquisition, under this regulation—the amount;

*Example of an amount payable—*

fee for renewing the vehicle’s registration

*Example of an amount that has become payable because of an acquisition of the vehicle—*

the amount of an exemption from a fee in relation to the vehicle’s registration to which the acquirer is not entitled

- (c) the duty payable in relation to the acquisition under the *Duties Act 2001*;
- (d) if there is a gas system in the vehicle—a gas compliance document for the system;
- (e) if the acquisition involves a disposal to which the *Transport Operations (Road Use Management—Vehicle Standards and Safety) Regulation 2021*, section 75 applies—prescribed evidence that an inspection certificate was in effect for the vehicle at the time of the disposal.

#### **43 Dealer must give notice of acquisition**

- (1) A dealer who acquires a registered vehicle must—
- (a) give the chief executive notice of the acquisition; and

*Note—*

See part 9, division 3 for requirements for particular customer communications.

- (b) ensure the notice is given to the chief executive within 14 days after the acquisition, unless the dealer has a reasonable excuse.

Maximum penalty—16 penalty units.

- (2) If the dealer acquires the registered vehicle from another dealer (the *disposing dealer*), subsection (1) does not apply if both dealers agree, in writing, that the disposing dealer will apply, or give notice, under section 44 within 14 days after the acquisition.

#### 44 Application for transfer, or notice of disposal, by disposer of registered vehicle

- (1) A disposer of a registered vehicle may—
  - (a) apply to the chief executive to transfer the vehicle's registration to the acquirer of the vehicle; or

*Note—*

See part 9, division 2 for requirements for particular applications.

- (b) give the chief executive a notice (a *disposal notice*) of the disposer's disposal of the vehicle.

*Note—*

See part 9, division 3 for requirements for particular customer communications.

- (2) An application under subsection (1)(a) must be accompanied by the following—
  - (a) if there is a gas system in the registered vehicle—a gas compliance document for the system;
  - (b) if the acquisition involves a disposal to which the *Transport Operations (Road Use Management—Vehicle Standards and Safety) Regulation 2021*, section 75 applies—prescribed evidence that an inspection certificate was in effect for the vehicle at the time of the disposal.

[s 45]

---

**45 Statement to be given if particular details of disposer can not be provided**

- (1) This section applies if an acquirer of a registered vehicle can not state the full name and address, or include the signature, of the disposer of the vehicle in—
  - (a) an application to transfer the vehicle’s registration under section 42; or
  - (b) a notice of the acquisition under section 43(1).
- (2) The acquirer must give a statement to the chief executive to the effect that the acquirer can not state the full name and address, or include the signature, of the disposer.

*Note—*

See part 9, division 3 for requirements for particular customer communications.

**46 Chief executive may require acquirer to apply for transfer of registration**

- (1) This section applies if the chief executive is satisfied an acquirer of a registered vehicle has not applied to transfer the vehicle’s registration under section 42.
- (2) The chief executive may, by written notice given to the acquirer, require the acquirer to comply with section 42 within 14 days after the notice is given.
- (3) The acquirer must comply with the notice unless the acquirer has a reasonable excuse.

Maximum penalty—16 penalty units.

*Note—*

See also section 59(1)(b).

**47 Dealer from whom acquirer acquires vehicle must apply for transfer of registration**

- (1) This section applies if—

- 
- (a) an acquirer acquires a registered vehicle from a dealer; and
  - (b) the dealer accepts from the acquirer an amount mentioned in section 42(3)(a), (b) or (c).
- (2) The dealer must—
- (a) apply to the chief executive on the acquirer’s behalf to transfer the registered vehicle’s registration to the acquirer; and
- Note—*
- See part 9, division 2 for requirements for particular customer applications.
  - (b) ensure the application is made within 14 days after the acquisition, unless the dealer has a reasonable excuse.
- Maximum penalty—16 penalty units.
- (3) Section 42(3) applies to the application as if it were an application made under that section.

**48 Chief executive may update register on receiving application, notice or statement**

- (1) Subsection (2) applies if the chief executive—
  - (a) receives an application to transfer a registered vehicle’s registration to an acquirer under section 42, 44(1)(a) or 47; or
  - (b) receives a notice about an acquisition of a registered vehicle under section 43(1); or
  - (c) receives a statement given under section 45(2) and is satisfied the information contained in the statement is correct.
- (2) The chief executive may—
  - (a) record in the register the transfer of the registered vehicle’s registration to the acquirer and the date of the acquisition; and

[s 49]

---

- (b) substitute the name and address of the acquirer of the registered vehicle for those of the registered operator of the vehicle recorded in the register; and
  - (c) amend the register to record the postal address, or lack of a postal address, for the acquirer; and
  - (d) make available to the acquirer an updated registration certificate for the vehicle.
- (3) If the chief executive receives a disposal notice under section 44(1)(b), the chief executive may—
- (a) record in the register the date of disposal; and
  - (b) substitute the name and address of the acquirer of the registered vehicle for those of the registered operator of the vehicle recorded in the register; and
  - (c) amend the register to record the postal address, or lack of a postal address, for the acquirer.
- (4) If the chief executive acts under subsection (3), the acquirer is taken to be the registered operator of the vehicle until the chief executive receives—
- (a) another disposal notice for the vehicle; or
  - (b) an application to transfer the vehicle’s registration to another person.

## **49 Transferring registration under legal process**

- (1) A person who acquires a registered vehicle under a legal process must—
- (a) give the chief executive notice of the acquisition; and
- Note—*
- See part 9, division 3 for requirements for particular customer communications.
- (b) ensure the notice is given to the chief executive within 14 days after the acquisition, unless the person has a reasonable excuse.

Maximum penalty—16 penalty units.

- 
- (2) A person who, by repossessing a registered vehicle that is not redeemed within 28 days after the repossession, acquires the vehicle must—
- (a) give the chief executive—
    - (i) notice of the repossession; and
    - (ii) details of the proposed registered operator of the vehicle; and

*Note—*

See part 9, division 3 for requirements for particular customer communications.

- (b) ensure the notice and details are given to the chief executive within a further 7 days, unless the person has a reasonable excuse.

Maximum penalty—16 penalty units.

- (3) If a person mentioned in subsection (1) or (2) can not include the signature of the vehicle's registered operator in a notice given under this section, the person must give the chief executive a statement to that effect with the notice.

*Note—*

See part 9, division 3 for requirements for particular customer communications.

- (4) Subsection (5) applies if—
- (a) a notice given to the chief executive under subsection (1) or (2) includes the signature of the vehicle's registered operator; or
  - (b) the chief executive is satisfied—
    - (i) the information contained in a statement given by a person under subsection (3) is correct; and
    - (ii) the person has a lawful entitlement to the vehicle.
- (5) The chief executive may—
- (a) record in the register the transfer of the registered vehicle's registration to the proposed registered operator

[s 50]

---

- of the vehicle, including the day of the acquisition stated in the notice; and
- (b) substitute the name and address of the person for those of the existing registered operator recorded in the register; and
  - (c) amend the register to record the postal address, or lack of a postal address, for the person; and
  - (d) make an updated registration certificate for the vehicle available to the person.
- (6) Section 42(3) applies to the notice as if it were an application made under that section.

**50 Chief executive may refuse to record transfer of registration**

- (1) The chief executive may refuse to record in the register a transfer of a registered vehicle's registration if—
  - (a) both of the following apply—
    - (i) the vehicle is a conditionally registered vehicle;
    - (ii) the conditional registration guideline or heavy vehicle standards exemption applying to the vehicle contains a condition that the registration is not transferable; or
  - (b) the chief executive reasonably believes—
    - (i) there is uncertainty about the ownership, possession or control of the vehicle; or
    - (ii) the description of the vehicle as recorded in the register may be inaccurate; or
  - (c) the chief executive would, if the vehicle were the subject of a registration application for a vehicle, refuse the application.
- (2) If the chief executive is given a copy of a current order of an Australian court prohibiting the transfer of a vehicle's

registration, the chief executive must not record a transfer of the registration in the register.

- (3) Nothing in this section limits the chief executive's power to refuse to record a transfer of a vehicle's registration.

*Note—*

See also section 19M of the Act.

## **51 If recording of transfer refused**

- (1) If the chief executive decides to refuse to record in the register a transfer of a vehicle's registration to a proposed registered operator, the chief executive must give the proposed registered operator written notice of the refusal.
- (2) The notice must state—
  - (a) the decision to refuse; and
  - (b) the reasons for the refusal; and
  - (c) that the decision may be reviewed under section 213.

## **Division 4 Cancelling registration**

### **Subdivision 1 Cancellation by application**

#### **52 Application by registered operator**

- (1) The registered operator of a vehicle may apply to the chief executive to cancel the vehicle's registration if—
  - (a) the registered operator is a dealer and the vehicle is for sale; or
  - (b) the vehicle—
    - (i) has been stolen; or
    - (ii) has been taken out of Queensland; or
    - (iii) has stopped being used on roads; or

[s 53]

---

(iv) is a total loss.

*Note—*

See part 9, division 2 for requirements for particular applications.

- (2) If the application is made under subsection (1)(b)(i), the application must include a statement by, or on behalf of, the registered operator stating the reference number for the police report about the theft.
- (3) If the application is made under subsection (1)(b)(iv), the application must be accompanied by the notifiable information for the vehicle, other than whether the vehicle is a repairable write-off or a statutory write-off.
- (4) If a person makes an application under subsection (1) on behalf of the registered operator of a vehicle, the application must be accompanied by written evidence of the person's appointment as the registered operator's agent.

### **53 Application by person acting under authority of court to sell vehicle**

- (1) A person acting under the authority of a court to sell a vehicle may apply to the chief executive to cancel the vehicle's registration.

*Note—*

See part 9, division 2 for requirements for particular applications.

- (2) The application must be accompanied by written evidence, to the satisfaction of the chief executive, of the authority.

### **54 Additional requirements for application under s 52 or 53**

- (1) An application to cancel a vehicle's registration under section 52 or 53 must be accompanied by—
  - (a) if a number plate for the vehicle has been lost, stolen or destroyed—
    - (i) a statement advising of the loss, theft or destruction; and

- (ii) any number plate for the vehicle, other than a special plate, that is not lost, stolen or destroyed; or
  - (b) otherwise—the number plates, other than special plates, for the vehicle.
- (2) Subsection (1) does not apply to an application to cancel a category 2 vehicle’s registration if—
- (a) the number plate for the vehicle is a national heavy vehicle number plate; and
  - (b) the vehicle is equivalently registered.

## **55 Application by local government**

- (1) The chief executive officer of a local government may apply to the chief executive to cancel a vehicle’s registration if—
- (a) section 100(3) to (11) of the Act applies in relation to the vehicle and a person has not obtained possession of the vehicle under section 100(6) of the Act; or
  - (b) the local government may dispose of the vehicle under a local law.
- (2) The application must—
- (a) include a statement that the chief executive officer of the local government has, in relation to the vehicle, complied with—
    - (i) section 100(4), (5), and (6)(a) of the Act; or
    - (ii) a local law that provides for the disposal of the vehicle; and
  - (b) be accompanied by any number plates for the vehicle, other than special plates, that were attached to the vehicle at the time the vehicle was removed and detained under section 100(3) of the Act.

*Note—*

See part 9, division 2 for requirements for particular applications.

## **56 Application by commissioner**

- (1) The commissioner may apply to the chief executive to cancel a vehicle's registration if the vehicle—
  - (a) becomes the property of the State under the *Police Powers and Responsibilities Act 2000*, section 74B(2)(a), 74F(2)(a) or 101(6)(a); or
  - (b) is, or is taken to have been, forfeited to the State under the *Police Powers and Responsibilities Act 2000*, section 118(3), 118A(3) or 766(4)(a).
- (2) The application must—
  - (a) include a statement that the vehicle has become the property of, or has been or is taken to have been forfeited to, the State under the *Police Powers and Responsibilities Act 2000*; and
  - (b) be accompanied by any number plates for the vehicle, other than special plates, that were attached to the vehicle at the time the vehicle became the property of, or was forfeited or taken to have been forfeited, to the State under the *Police Powers and Responsibilities Act 2000*.

*Note—*

See part 9, division 2 for requirements for particular applications.

## **Subdivision 2 Cancellation by chief executive**

### **57 Equivalently registered vehicles**

- (1) This section applies if the chief executive knows a vehicle is equivalently registered.
- (2) The chief executive may cancel the vehicle's registration.
- (3) If the chief executive cancels a vehicle's registration under this section, the chief executive must record the cancellation in the register.

---

**58 Noncompliance with notice about defective or unsafe vehicle—Act, s 18**

- (1) Schedule 7 prescribes, for section 18(1)(s) of the Act, grounds on which the chief executive may cancel the registration of a registered vehicle.
- (2) If the chief executive decides to cancel the registration of a registered vehicle under section 19(2)(c)(iii) of the Act on a ground stated in schedule 7, the chief executive must—
  - (a) record the cancellation in the register; and
  - (b) include, in the written notice about the decision given under section 19(3) of the Act, a request that the person to whom the notice is given return the number plates for the vehicle to the chief executive within 14 days after the notice is given (the *return period*).
- (3) The person must comply with the request mentioned in subsection (2)(b) within the return period.

Maximum penalty—20 penalty units.

- (4) However, if a number plate for the vehicle has been lost, stolen or destroyed, the person does not contravene subsection (3) if the person gives the chief executive notice of the loss, theft or destruction within the return period.

*Note—*

See part 9, division 3 for requirements for particular customer communications.

**59 Other grounds—Act, s 18**

- (1) For section 18(1)(s) of the Act, a ground exists for the chief executive to cancel the registration of a vehicle if—
  - (a) the vehicle does not comply with the vehicle laws applying to the vehicle; or
  - (b) an acquirer of the vehicle does not comply with a notice given to the acquirer under section 46(2); or
  - (c) each of the following applies—

[s 60]

---

- (i) before the recorded expiry day for the registration, all or part of the total amount payable for the registration, or the renewal of the registration, is purportedly paid using a payment method other than a cash payment;
  - (ii) the total amount payable in relation to the registration or renewal is not received by the chief executive on or before the recorded expiry day; or
  - (d) the vehicle is recorded in the register as a written-off vehicle.
- (2) If the chief executive decides to cancel the vehicle's registration under section 19(2)(c)(iii) of the Act on a ground mentioned in subsection (1), the chief executive must—
- (a) record the cancellation in the register; and
  - (b) include, in the written notice about the decision given under section 19(3) of the Act, a request that the person to whom the notice is given return the number plates for the vehicle to the chief executive within 14 days after the notice is given (the *return period*).
- (3) The person must comply with the request mentioned in subsection (2)(b) within the return period.

Maximum penalty—20 penalty units.

- (4) However, if a number plate for the vehicle has been lost, stolen or destroyed, the person does not contravene subsection (3) if the person gives the chief executive notice of the loss, theft or destruction within the return period.

*Note—*

See part 9, division 3 for requirements for particular customer communications.

## **60 Cancellation of heavy vehicle's registration by court**

- (1) This section applies if a court makes an order under the Heavy Vehicle National Law (Queensland), section 598(2) that the registration of a heavy vehicle is cancelled.

- (2) The chief executive must—
  - (a) record the cancellation in the register; and
  - (b) give written notice to the last registered operator of the heavy vehicle—
    - (i) stating the cancellation has been recorded; and
    - (ii) requiring the registered operator to return the vehicle's number plates to the chief executive within 14 days after the notice is given (the *return period*).
- (3) The registered operator must comply with the requirement mentioned in subsection (2)(b)(ii) within the return period.  
Maximum penalty—20 penalty units.
- (4) However, if a number plate for the vehicle has been lost, stolen or destroyed, the person does not contravene subsection (3) if the person gives the chief executive notice of the loss, theft or destruction within the return period.

*Note—*

See part 9, division 3 for requirements for particular customer communications.

## **60A Entities prescribed—Act, ss 19D and 19E**

- (1) For section 19D of the Act, definition *advertising standards entity*, Ad Standards ABN 54 003 179 673 is prescribed.
- (2) For section 19E(4) of the Act, definition *community panel*, the Ad Standards Community Panel is prescribed.

## **Subdivision 3 Cancellation**

### **61 Cancelling registration**

- (1) If the chief executive receives an application to cancel a vehicle's registration under subdivision 1, the chief executive may—

[s 62]

---

- (a) cancel the vehicle's registration; and
  - (b) record the cancellation in the register.
- (2) However, this section does not apply if the chief executive is already taking action to cancel the vehicle's registration under section 58 or 59.

**62 When cancellation on application by vehicle's registered operator takes effect**

- (1) This section applies if a vehicle's registration is cancelled on an application by the registered operator under section 52.
- (2) If the application is made under section 52(1)(a) or (b)(ii) or (iii), the cancellation takes effect on the day the chief executive receives the application.
- (3) However, if the application is made under section 52(1)(b)(ii) and the chief executive is satisfied the vehicle is equivalently registered, the cancellation is taken to have been effective on the day immediately after the day the vehicle became equivalently registered.
- (4) If the application is made under section 52(1)(b)(i), the cancellation takes effect, or is taken to have been effective, on the day after the vehicle is reported as stolen to the Queensland Police Service.
- (5) If the application is made under section 52(1)(b)(iv), the cancellation takes effect, or is taken to have been effective, on the day after the day the vehicle became a total loss.

**63 When cancellation by chief executive under s 57 takes effect**

If the chief executive cancels a vehicle's registration under section 57, the cancellation is taken to have been effective on the day immediately after the day the vehicle was registered in the other State.

## 64 When cancellation on other grounds takes effect

A cancellation of registration, other than a cancellation mentioned in section 62 or 63, takes effect on the day the chief executive records the cancellation in the register.

## Subdivision 4 Refunding or recovering registration fees

### 65 Partial refund of vehicle registration fee

- (1) This section applies if the chief executive cancels a vehicle's registration under section 57(2) or 61.
- (2) The chief executive must partially refund the registration fee paid for the vehicle to the last registered operator of the vehicle.
- (3) The refund is worked out using the following formula—

$$\textit{refund} = \frac{\textit{number of days}}{365} \times \textit{vehicle registration fee for 1 year}$$

where—

*number of days* means the number of unexpired whole days of the term of registration for which the registration fee was paid, starting on the day the cancellation of the registration takes effect under this division.

- (4) However, the chief executive may deduct from the refund—
  - (a) the administration fee stated in schedule 4, part 5 for making the refund; and
  - (b) any unpaid fees payable by the vehicle's last registered operator under the Act.

**66 Chief executive may recover proportion of unpaid registration fee**

- (1) This section applies if the chief executive cancels a vehicle's registration on the ground mentioned in section 59(1)(c).
- (2) The chief executive may, by written notice, require the last registered operator of the vehicle to pay the total of any unpaid amount payable in relation to the registration, adjusted in proportion to the period ending on the day the registration is cancelled.
- (3) The registered operator must—
  - (a) pay the adjusted amount to the chief executive; and
  - (b) ensure the payment is made within 28 days after the chief executive gives the notice, unless the person has a reasonable excuse.

Maximum penalty—

- (a) if the amount relates to a category 1 vehicle—20 penalty units; or
- (b) if the amount relates to a category 2 vehicle—60 penalty units.

**Division 5 Other provisions relating to registration**

**67 Vehicle inspections**

- (1) The chief executive may require a vehicle for which a registration application has been made to be brought to the chief executive for an inspection—
  - (a) before the vehicle is registered; or
  - (b) if the vehicle is recorded in the register as a repairable write-off—before the chief executive changes the register so the vehicle is no longer recorded as a repairable write-off.

- (2) Subsection (3) applies if, when the chief executive inspects the vehicle—
- (a) an identifying number placed on the vehicle by the vehicle’s manufacturer—
    - (i) is not clearly legible; or
    - (ii) appears to have been altered or defaced; or
  - (b) if the vehicle is recorded in the register as a repairable write-off that has been repaired—the vehicle no longer has an identifying number.

(3) The chief executive may give a replacement identifying number for the vehicle.

(4) If the chief executive gives a replacement identifying number for a motor vehicle under subsection (3) and a permission mentioned in section 134(b)(ii) of the Act is given by the commissioner for the number, the applicant must ensure the number is placed on the vehicle.

Maximum penalty—8 penalty units.

(5) The applicant must comply with subsection (4) even if the applicant does not intend to register the vehicle.

(6) The chief executive may, by written notice given to the applicant, request the return of the vehicle for further inspection if the chief executive considers a particular recorded in the register for the vehicle may not be accurate after—

- (a) the vehicle has been registered; or
- (b) the register has been changed so the vehicle is no longer recorded as a repairable write-off.

(7) The applicant must comply with the notice.

Maximum penalty—8 penalty units.

## **68 Registered operator must notify chief executive of particular changes**

- (1) This section applies if any of the following for a registered vehicle changes—
  - (a) the name or address of the registered operator of the vehicle;
  - (b) the vehicle’s garage address;
  - (c) the vehicle’s nominated purpose of use;
  - (d) if the vehicle is a category 2 vehicle—the vehicle’s nominated configuration.

- (2) The registered operator of the vehicle must—

- (a) give the chief executive—
  - (i) notice of the change; and

*Note—*

See part 9, division 3 for requirements for particular customer communications.

- (ii) for a change of the registered operator’s name—written evidence, satisfactory to the chief executive, of the change; and
- (b) ensure the notice and evidence are given to the chief executive within 14 days after the change, unless the registered operator has a reasonable excuse.

Maximum penalty—8 penalty units.

- (3) In this section—

***address*** includes a postal address.

## **69 Requirements relating to modification of vehicles**

- (1) If a person modifies a registered vehicle, the registered operator of the vehicle must, within 14 days after the modification, give the chief executive notice of the modification.

Maximum penalty—8 penalty units.

*Note—*

See part 9, division 3 for requirements for particular customer communications.

- (2) Subsection (3) applies if—
  - (a) the vehicle is a category 2 vehicle; and
  - (b) at least 1 of the following applies—
    - (i) the modification changes a detail for the vehicle recorded in the register under section 112(2)(b), (c) or (d);
    - (ii) because of the modification, the registration fee applicable to the vehicle is reassessed under section 71 as being higher than the registration fee paid for its current registration.
- (3) The registered operator must not use the vehicle on a road until—
  - (a) the chief executive has been notified of the modification; and
  - (b) if subsection (2)(b)(ii) applies—the registered operator has complied with section 71(5).
- (4) In this section—

***modify***, a registered vehicle, means modify any of the following—

  - (a) the vehicle’s axle configuration;
  - (b) the vehicle’s carrying capacity;
  - (c) a feature of the vehicle whose details must be recorded in the register under section 112(2)(b), (c) or (d);
  - (d) any other particular of the vehicle that is recorded in the register.

## 70 Recording change of identifying number or other particulars for vehicle

- (1) This section applies if the chief executive—

[s 71]

---

- (a) gives a replacement identifying number for a vehicle under section 67(3); or
  - (b) is satisfied particulars given under section 68(2) or 69 in relation to a registered vehicle are correct.
- (2) The chief executive must—
- (a) record the identifying number or particulars in the register; and
  - (b) make available to the registered operator of the vehicle an updated registration certificate for the vehicle.

## **71 Reassessment of registration fee on recording of changed particulars**

- (1) This section applies if—
- (a) under section 70(2)(a), the chief executive records in the register particulars given in relation to a registered vehicle; and
  - (b) the particulars are for a change of the registered vehicle's purpose of use or modifying the registered vehicle.
- (2) The chief executive may reassess the registration fee payable for the registered vehicle for the term (the *unexpired term*)—
- (a) starting on the day of the change or modification; and
  - (b) ending on the day the registered vehicle's current term of registration expires.
- (3) If the amount of the reassessed registration fee is less than the amount of the registration fee already paid for the unexpired term, the chief executive must refund the difference between the amounts for the unexpired term to the registered operator of the registered vehicle.
- (4) If the amount of the reassessed registration fee is more than the amount of the fee already paid for the unexpired term, the chief executive may, by written notice given to the registered operator of the vehicle, require the registered operator to pay

the difference between the amounts for the unexpired term within 28 days after the notice is given.

- (5) The registered operator must comply with the notice unless the registered operator has a reasonable excuse.

Maximum penalty—60 penalty units.

## 72 Application of Act, s 56

Section 56 of the Act does not apply to registration, or renewal of registration, of a vehicle or dealer plate.

# Part 4 When vehicle registration unnecessary

## Division 1 Unregistered vehicle permits

### 73 Application for permit

- (1) A person may apply to the chief executive for a permit authorising the use of an unregistered vehicle on a road (an *unregistered vehicle permit*) for a term of not longer than 7 days.

*Note—*

See part 9, division 2 for requirements for particular applications.

- (2) However, a person may not make an application under subsection (1) in relation to a vehicle that is only eligible for conditional registration under section 18(2).
- (3) The application must—
- (a) state the term applied for; and
  - (b) be accompanied by—
    - (i) the fee stated in schedule 4, part 5 for the application; and

[s 74]

---

- (ii) an insurance certificate required under the *Motor Accident Insurance Act 1994* for the vehicle for the proposed term of the permit or the insurance premium payable under that Act for the certificate.

## **74 Grant of permit**

- (1) On receiving an application under section 73, the chief executive may—
  - (a) refuse the application under subsection (4); or
  - (b) grant the unregistered vehicle permit.
- (2) The chief executive may grant the unregistered vehicle permit on conditions.
- (3) If the chief executive grants the unregistered vehicle permit, the chief executive must record in the register the details required for the permit under section 115.
- (4) The chief executive must refuse the application if—
  - (a) the vehicle—
    - (i) does not comply with the vehicle laws applying to the vehicle; or
    - (ii) is recorded in the register, or in a register kept under a corresponding law to this regulation, as a written-off vehicle; or
    - (iii) does not have a chassis number or VIN; or
  - (b) a number plate confiscation notice has been attached to the vehicle under the *Police Powers and Responsibilities Act 2000*, section 74H(2).

## **75 If permit not granted**

If the chief executive refuses an application under section 74, the chief executive must advise the applicant of—

- (a) the decision to refuse; and
- (b) the reasons for the refusal.

---

## **76 Requirement to carry permit**

- (1) The holder of an unregistered vehicle permit for a vehicle must, unless the holder has a reasonable excuse, ensure that at all times when the vehicle is being used under the permit on a road—
  - (a) if the vehicle is a trailer—the driver of the vehicle towing the trailer carries the permit in the towing vehicle; or
  - (b) otherwise—the driver of the vehicle carries the permit.Maximum penalty—12 penalty units.
- (2) Subsection (3) applies if an unregistered vehicle is being used on a road under an unregistered vehicle permit by a person other than the holder of the permit.
- (3) The person must, unless the person has a reasonable excuse—
  - (a) if the vehicle is a trailer—carry the permit in the vehicle towing the trailer; or
  - (b) otherwise—carry the permit.Maximum penalty—12 penalty units.

## **Division 2 Dealer plates**

### **Subdivision 1 Preliminary**

#### **77 Designation of dealer plates**

The chief executive may designate a number plate as a dealer plate.

*Note—*

An unregistered vehicle may be driven on a road if the vehicle has a registered dealer plate attached to it under section 96. See section 10(2)(g).

## **Subdivision 2      Registration**

### **78      Registration application**

- (1) A person may apply to the chief executive for registration of a dealer plate in a person's name.

*Note—*

See part 9, division 2 for requirements for particular applications.

- (2) The application must—
  - (a) state the term of registration applied for; and
  - (b) identify and describe the nature of the person's business for which the dealer plate is required; and
  - (c) be accompanied by—
    - (i) the registration fee for the dealer plate; and
    - (ii) if the term of registration applied for is 6 months—the surcharge stated in schedule 4, part 4 for processing the application; and
    - (iii) an insurance certificate required under the *Motor Accident Insurance Act 1994* for the proposed term of registration or the insurance premium payable under that Act for the certificate.

### **79      Deciding registration application**

- (1) The chief executive must, after considering the registration application—
  - (a) refuse the application under subsection (2); or
  - (b) grant the application.
- (2) The chief executive must refuse the application if the chief executive is not satisfied the person in whose name the registration is to be recorded requires the dealer plate for the conduct of the person's business.

---

## **80 If registration application refused**

- (1) If the chief executive decides to refuse a registration application for a dealer plate under section 79, the chief executive must give the applicant written notice of the refusal.
- (2) The notice must state—
  - (a) the decision to refuse; and
  - (b) the reasons for the refusal; and
  - (c) that the decision may be reviewed under section 213.

## **81 If registration application granted**

If the chief executive decides to grant a registration application for a dealer plate under section 79(1)(b), the chief executive must—

- (a) assign a registration number for the dealer plate to the registered operator for the plate; and
- (b) record in the register the details required for the dealer plate under section 112(1); and
- (c) give the registered operator the dealer plate; and
- (d) make available to the registered operator a registration certificate for the dealer plate.

## **82 Term of registration**

- (1) A dealer plate may be registered for a term of either—
  - (a) 1 year; or
  - (b) 6 months.
- (2) The term of registration starts on the day the chief executive's receipt for payment of the fees payable under this regulation is given to the applicant for the registration.
- (3) The term of registration expires—

[s 83]

---

- (a) if the registration is cancelled under subdivision 5 before the recorded expiry day for the registration—when the cancellation takes effect; or
- (b) otherwise—at the end of the recorded expiry day for the registration.

### **83 Registration not transferable**

The registration of a dealer plate is not transferable.

## **Subdivision 3 Renewing registration**

### **84 Renewal notice**

- (1) The chief executive may, before the recorded expiry day for a dealer plate's registration, give a notice about renewing the registration to the registered operator for the plate.
- (2) The notice must state—
  - (a) the recorded expiry day for the registration; and
  - (b) that if the registration is not renewed on or before the recorded expiry day, the registration expires; and
  - (c) that if the registration is renewed after the recorded expiry day, the renewal application for the registration must be accompanied by the administrative fee stated in schedule 4, part 4 for the renewal.
- (3) However, if the chief executive does not send, or the registered operator does not receive, the notice, the non-receipt of the notice by the registered operator does not affect—
  - (a) the expiry of the registration; or
  - (b) if the registered operator intends to use an unregistered vehicle to which the dealer plate is attached on a road after the recorded expiry day—the registered operator's obligation to renew the registration before it expires.

---

## 85 Renewal application

- (1) The registered operator for a dealer plate may apply to the chief executive for renewal of the plate's registration.

*Note—*

See part 9, division 2 for requirements for particular applications.

- (2) The application must be made on or before the day that is 3 months after the recorded expiry day for the registration.
- (3) Nothing in subsection (2) has the effect of retrospectively renewing registration of a dealer plate.

## 86 Requirements for renewal application

A renewal application for a dealer plate must—

- (a) state the term of registration, of either 1 year or 6 months, applied for; and
- (b) be accompanied by—
  - (i) the registration fee for the dealer plate; and
  - (ii) if the applicant is required to pay a surcharge for processing the application under section 90—the surcharge stated in schedule 4, part 4 for processing the application; and
  - (iii) an insurance certificate required under the *Motor Accident Insurance Act 1994* for the proposed term of registration or the insurance premium payable under that Act for the certificate; and
  - (iv) if the application is made after the registration expires—the administrative fee stated in schedule 4, part 4 for the renewal.

## 87 Deciding renewal application

- (1) The chief executive must, after considering a renewal application for a dealer plate—
  - (a) refuse the application under subsection (2); or

[s 88]

---

- (b) grant the application.
- (2) The chief executive must refuse the application if the chief executive is not satisfied the person in whose name the registration is to be recorded requires the dealer plate for the conduct of the person's business.

### **88 If renewal application refused**

- (1) If the chief executive decides to refuse a renewal application for a dealer plate under section 87, the chief executive must give the applicant written notice of the refusal.
- (2) The notice must state—
  - (a) the decision to refuse; and
  - (b) the reasons for the refusal; and
  - (c) that the decision may be reviewed under section 213.

### **89 When renewed term of registration expires**

- (1) The day a renewed term of a dealer plate's registration expires must be worked out as if the term had started on the day after the recorded expiry day for the registration.
- (2) Nothing in subsection (1) has the effect of retrospectively registering a dealer plate.

### **90 When surcharge is payable for renewal**

- (1) This section applies if a renewal application for a dealer plate is for renewal of the plate's registration for a term of 6 months.
- (2) Also, this section applies if—
  - (a) a renewal application for a dealer plate is accompanied by an insurance certificate mentioned in section 86(b)(iii); and
  - (b) despite the requirement under section 86(b)(i), the applicant underpays the registration fee for the renewal

by more than \$1 below what the fee would be if the renewal were for 1 year's registration.

- (3) In addition, this section applies if—
  - (a) a renewal application for a vehicle is not accompanied by an insurance certificate mentioned in section 86(b)(iii); and
  - (b) the applicant underpays the registration-related amount for the renewal by more than \$1 below what the registration-related amount would be if—
    - (i) the registration fee payable under section 86(b)(i) for the renewal was for 1 year's registration; and
    - (ii) the CTP insurance premium payable under section 86(b)(iii) in relation to the renewal was the lowest premium set by a CTP insurer for a CTP insurance policy covering 1 year's registration.
- (4) The applicant must pay the surcharge stated in schedule 4, part 4 for processing the application.

## **91 Term of registration if overpayment or underpayment of registration-related amount and any surcharge**

- (1) This section applies if—
  - (a) a renewal application for a dealer plate is not accompanied by an insurance certificate mentioned in section 86(b)(iii); and
  - (b) the applicant overpays or underpays the total of the following amounts—
    - (i) the registration-related amount for the renewal;
    - (ii) a surcharge payable for processing the application under section 90(4).
- (2) The chief executive may renew the registration for a term adjusted in proportion to the amount paid after deducting—
  - (a) the surcharge; and

[s 91]

---

- (b) if an administrative fee stated in schedule 4, part 4 is payable for the renewal—the administrative fee.
- (3) However, if the amount paid is more than \$1 below what the total of the registration-related amount and the surcharge would be if a CTP insurance premium, payable under section 86(b)(iii) in relation to the renewal for 6 months, was the lowest premium set by a CTP insurer for a CTP insurance policy, the chief executive—
  - (a) must not renew the dealer plate’s registration under subsection (2); and
  - (b) must refund the amount paid to the applicant.
- (4) Also, if the amount paid is, on a proportionate basis, more than the registration-related amount for the renewal that would be payable if the registration were to be renewed for 14 months, the chief executive—
  - (a) may only renew the registration for 14 months; and
  - (b) must refund the difference between the amount paid and the registration-related amount for the 14-month renewal to the applicant.
- (5) If the term of registration would, other than for this subsection, not be a whole number of days, the chief executive must—
  - (a) round the term down to the nearest whole day; and
  - (b) credit the difference between the amount paid and the total of the registration-related amount for the renewal and any surcharge payable for the renewal to the applicant.
- (6) The chief executive must—
  - (a) if subsection (3) applies—notify the applicant that the amount paid is being refunded because it is below the minimum amount required to enable renewal of registration; or
  - (b) otherwise—make available to the applicant a notice stating—

- (i) the term of registration for the dealer plate; and
- (ii) if subsection (4) or (5) applies—the reason for any amount refunded or credited to the applicant.

**92 Administrative fee for late payment if purported non-cash payment not received**

- (1) This section applies in relation to a renewal application for a dealer plate if—
  - (a) before the recorded expiry day for the dealer plate’s registration, all or part of the total amount payable for the renewal is purportedly paid using a payment method other than a cash payment; and
  - (b) the chief executive does not receive all of the total amount payable on or before the recorded expiry day; and
  - (c) after the recorded expiry day, all, or the remainder of, the total amount payable is paid to the chief executive.
- (2) The applicant for renewal must pay the administrative fee stated in schedule 4, part 4 for the renewal.

**93 When renewal of registration takes effect and requirement to record expiry day**

- (1) The renewal of a dealer plate’s registration takes effect—
  - (a) if all transactions relating to the renewal are completed on or before the recorded expiry day for the dealer plate’s registration—immediately after the expiry of the term being renewed; or
  - (b) otherwise—on the completion of all transactions relating to the renewal.
- (2) The chief executive must, on the completion of all transactions relating to the renewal, record in the register the day the renewed term of registration expires.

[s 94]

---

#### **94 Return of dealer plate if registration not renewed**

- (1) This section applies if a dealer plate's registration is not renewed on or before the day the renewal must be applied for under section 85(2).
- (2) The chief executive may, by written notice given to the last registered operator for the dealer plate, require the last registered operator to return the plate to the chief executive within 14 days after the notice is given (the *return period*).
- (3) The last registered operator must, within the return period—
  - (a) if the dealer plate has been lost, stolen or destroyed—give the chief executive notice of the loss, theft or destruction; or

*Note—*

See part 9, division 3 for requirements for particular customer communications.

- (b) otherwise—return the dealer plate to the chief executive.
- Maximum penalty—30 penalty units.

### **Subdivision 4 Using dealer plates**

#### **95 Definition for subdivision**

In this subdivision—

*dealer (trailer trade) plate* means a dealer plate described or identified in the register as a dealer plate for use on a trailer.

#### **96 Use of unregistered vehicle with registered dealer plate attached**

- (1) An unregistered vehicle may be used on a road if—
  - (a) a registered dealer plate is attached to the vehicle under section 97; and
  - (b) section 98 is complied with for the vehicle; and

- 
- (c) for a vehicle carrying a load or towing a vehicle carrying a load—section 99 is complied with for the vehicle; and
  - (d) for a trailer—section 100 is complied with for the vehicle.
- (2) However, subsection (1) does not apply to an unregistered vehicle that is—
- (a) not eligible for registration; or
  - (b) only eligible for limited access registration or zone access registration.

**97 Registered dealer plate to be attached in same way as number plate**

- (1) A registered operator for a registered dealer plate must, at all times when using an unregistered vehicle on a road with the dealer plate attached, ensure the dealer plate is attached to the rear of the vehicle in the way that would be required under section 118 if the dealer plate were the only number plate given for the vehicle.

Maximum penalty—12 penalty units.

- (2) For subsection (1), the registered dealer plate—
- (a) need not be permanently attached to the vehicle; but
  - (b) must be attached to the vehicle in a way that prevents substantial movement of the dealer plate.

**98 Using vehicles with registered dealer plates attached**

- (1) A person must not use, or permit to be used, a vehicle with a registered dealer plate attached to it on a road unless the vehicle is—
- (a) being demonstrated for its sale; or
  - (b) being delivered to a purchaser after its sale; or
  - (c) travelling to or from a workshop or another facility for—

[s 98]

---

- (i) painting, repairs or motor body construction work;  
or
  - (ii) otherwise preparing the vehicle for its sale; or
  - (iii) the fitting of optional equipment before delivery to a purchaser; or
- (d) being tested after having been painted or repaired, or after having been the subject of motor body construction work; or
- (e) being used for demonstration purposes for the conduct of an art union under the *Charitable and Non-Profit Gaming Act 1999*; or
- (f) being driven or towed for testing to confirm the safe operation of the vehicle as part of an inspection for obtaining an inspection certificate for the vehicle; or
- (g) being driven or towed to an AIS or departmental inspection site, if the vehicle is driven or towed to the AIS or site for inspection for obtaining an inspection certificate for the vehicle; or
- (h) recorded in the register as a repairable write-off and is being driven or towed to a written-off vehicle inspection site for obtaining a written-off vehicle inspection report; or
- (i) being driven or towed to a departmental service centre to be registered; or
- (j) being driven or towed from the manufacturer or a distributor of the vehicle to a dealer; or
- (k) being driven or towed between a dealer's premises and other premises of the same or a different dealer, whether or not the vehicle has been sold.

Maximum penalty—40 penalty units.

- (2) A person must not use, or permit to be used, a vehicle with a registered dealer plate attached to it on a road unless the registered operator for the dealer plate—
- (a) is the person who used the vehicle; or

- (b) authorised the person to use, or to permit another person to use, the vehicle.

Maximum penalty—40 penalty units.

- (3) A person must not use, or permit to be used, a vehicle with a registered dealer plate attached to it on a road unless the vehicle is used in the conduct of the business of the registered operator for the dealer plate.

Maximum penalty—40 penalty units.

- (4) However, subsections (1) to (3) do not apply to the person if—
- (a) the vehicle is being driven or towed as mentioned in subsection (1)(g), (h), (i), (j) or (k); and
- (b) the person is permitted to drive or tow the vehicle under section 11(1).

## **99 Attaching registered dealer plates, other than dealer (trailer trade) plates, to vehicles carrying loads**

- (1) A person must not use, or permit to be used, a vehicle with a registered dealer plate, other than a dealer (trailer trade) plate, attached to it on a road if the vehicle is—
- (a) carrying a load; or
- (b) towing another vehicle that is carrying a load.

Maximum penalty—40 penalty units.

- (2) However, a person does not contravene subsection (1) if the vehicle to which the registered dealer plate is attached is—
- (a) a boat trailer carrying a boat; or
- (b) towing a motor vehicle travelling on its rear wheels only, with its front part mounted on the towing vehicle; or
- (c) carrying a load only to demonstrate the vehicle for its sale, and not for hire or reward.

[s 100]

---

## **100 Using vehicles with dealer (trailer trade) plates attached**

A person may use, or permit to be used, a vehicle with a registered dealer (trailer trade) plate attached to it on a road only if the vehicle is—

- (a) a boat trailer that—
  - (i) is carrying 1 or more other boat trailers and is being towed from the premises of the manufacturer or a distributor of any of the trailers to a dealer; or
  - (ii) is carrying a boat; or
- (b) another type of trailer that—
  - (i) is not carrying a load; or
  - (ii) is carrying a load only to demonstrate the trailer for its sale, and not for hire or reward.

Maximum penalty—40 penalty units.

## **Subdivision 5 Cancelling registration**

### **101 Application by registered operator**

- (1) The chief executive may cancel the registration of a dealer plate if the registered operator for the dealer plate—
  - (a) applies to the chief executive to cancel the registration; and
    - Note—*  
See part 9, division 2 for requirements for particular applications.
  - (b) either—
    - (i) returns the dealer plate to the chief executive; or
    - (ii) gives, or has given, the chief executive notice of the loss, theft or destruction of the dealer plate.

*Note—*

See part 9, division 3 for requirements for particular customer communications.

- (2) The chief executive must record the cancellation in the register.

## **102 Cancellation because of ending of or material change in business**

- (1) This section applies to the registered operator for a dealer plate if either of the following events happen—
  - (a) the registered operator stops carrying on the business for which the dealer plate was registered;
  - (b) the nature of the registered operator’s business as described in the application to register the dealer plate changes.
- (2) The registered operator for the dealer plate must—
  - (a) give the chief executive notice about the event; and

*Note—*

See part 9, division 3 for requirements for particular customer communications.

- (b) return the dealer plate to the chief executive; and
- (c) comply with paragraphs (a) and (b) within 14 days after the event happens, unless the registered operator has a reasonable excuse.

Maximum penalty—30 penalty units.

- (3) However, if the dealer plate has been lost, stolen or destroyed, the registered operator does not contravene subsection (2) if the registered operator gives the chief executive notice of the loss, theft or destruction within the period mentioned in subsection (2)(c).

*Note—*

See part 9, division 3 for requirements for particular customer communications.

[s 103]

---

- (4) On receiving a notice under subsection (2)(a), the chief executive must cancel the registration of the dealer plate and record the cancellation in the register.

### **103 Cancellation on other grounds—Act, s 18**

- (1) For section 18(1)(s) of the Act, a ground exists for the chief executive to cancel the registration of a dealer plate if—
  - (a) all or part of the fee for registering, or renewing registration of, the dealer plate is not paid by the day the fee is required to be received by the chief executive under this regulation; or
  - (b) the registered operator for the dealer plate contravenes section 102(2)(a) in relation to the dealer plate.
- (2) If the chief executive decides to cancel the registration of the dealer plate under section 19(2)(c)(iii) of the Act on a ground mentioned in subsection (1), the chief executive must—
  - (a) record the cancellation in the register; and
  - (b) include, in the written notice about the decision given under section 19(3) of the Act, a request that the person to whom the notice is given return the dealer plate to the chief executive within 14 days after the notice is given (the *return period*).
- (3) The person must comply with the request mentioned in subsection (2)(b) within the return period.

Maximum penalty—30 penalty units.

- (4) However, if the dealer plate has been lost, stolen or destroyed, the person does not contravene subsection (3) if the person gives the chief executive notice of the loss, theft or destruction within the return period.

*Note—*

See part 9, division 3 for requirements for particular customer communications.

---

## **104 When cancellation takes effect**

The cancellation of a dealer plate's registration takes effect—

- (a) if the chief executive cancels the registration under section 101—immediately after the registered operator for the dealer plate has complied with section 101(1); or
- (b) otherwise—when the chief executive records the cancellation in the register.

## **105 Recovering proportion of registration amount**

- (1) This section applies if the chief executive cancels a dealer plate's registration on the ground mentioned in section 103(1)(a).
- (2) The chief executive may, by written notice, require the last registered operator for the dealer plate to pay the total of any unpaid amount payable in relation to the registration, adjusted in proportion to the period ending on the day the registration is cancelled.
- (3) The last registered operator must pay the adjusted amount within 28 days after the chief executive gives the notice.

Maximum penalty—30 penalty units.

## **Subdivision 6 Miscellaneous**

### **106 Application of Act, s 56**

Section 56 of the Act does not apply to registration, or renewal of registration, of a vehicle or dealer plate.

## **Division 3 Vehicles temporarily in Queensland**

### **107 Application of division**

- (1) This division applies to a vehicle if—

[s 108]

---

- (a) the vehicle—
    - (i) does not have a garage address in Queensland; or
    - (ii) has had a garage address in Queensland for 14 days or less; and
  - (b) the vehicle is to be used on a road; and
  - (c) the vehicle—
    - (i) is equivalently registered; or
    - (ii) is registered in a foreign country under a law of the country about the registration of vehicles used on roads; or
    - (iii) may be used on a road under an authority or permit in force under a corresponding law to this regulation of another State relating to the use of unregistered vehicles, including a law relating to the other State's equivalent of dealer plates.
- (2) For subsection (1)(a), a category 2 vehicle's garage address is taken to be a garage address in Queensland if the vehicle is used mainly in Queensland for more than 3 months.

## 108 Use of vehicle on road

The vehicle may be used on a road if—

- (a) the vehicle carries and displays all number plates it is required, under a law, authority or permit mentioned in section 107(1)(c), to carry and display; and
- (b) the number plates are carried and displayed in the way required by—
  - (i) for a vehicle to which section 107(1)(c)(i) or (ii) applies—the corresponding law to this regulation under which the vehicle is registered; or
  - (ii) for a vehicle to which section 107(1)(c)(iii) applies—the corresponding law to this regulation under which the vehicle may be used on the road under the authority or permit; and

- (c) for a vehicle to which section 107(1)(c)(iii) applies—the vehicle is used under the authority or permit, so far as the authority or permit is capable of being applied to the use of the vehicle outside that State; and
- (d) the vehicle is insured—
  - (i) for a vehicle registered in a foreign country—under the *Motor Accident Insurance Act 1994*; or
  - (ii) for a vehicle registered in, or used under an approval granted by, another State—under a contract of insurance made under a corresponding law to the *Motor Accident Insurance Act 1994* of the other State.

#### **109 Production of proof of particular matters or left-hand drive permit if vehicle registered in foreign country**

- (1) This section applies to the owner or person in charge of a vehicle to which section 107(1)(c)(ii) applies if—
  - (a) the vehicle is being used on a road; and
  - (b) an authorised officer asks the owner or person in charge to produce any of the following for inspection by the officer—
    - (i) proof of the vehicle’s current registration;
    - (ii) proof of a current CTP insurance policy for the vehicle;
    - (iii) if the vehicle is present in Australia under a temporary admission carnet—proof of the temporary admission carnet;
    - (iv) if the importation of the vehicle was approved under a status of forces agreement—proof of the approval;
    - (v) if the vehicle is a heavy vehicle that has the centre of a steering control to the left of the vehicle—the left-hand drive permit for the vehicle.

[s 110]

---

- (2) The owner or person in charge must comply with the request.  
Maximum penalty—8 penalty units.
- (3) For subsection (2), the owner or person in charge must comply with the request immediately, unless the owner or person in charge has a reasonable excuse.
- (4) In this section—

*left-hand drive permit*, for a heavy vehicle, means a permit, granted under the Heavy Vehicle National Law (Queensland), Chapter 3, Part 3.2, Division 3, exempting the vehicle from compliance with the Heavy Vehicle (Vehicle Standards) National Regulation, schedule 2, section 4(1).

*status of forces agreement* means an agreement between the Commonwealth and a foreign country allowing for the importation of vehicles by visiting military personnel.

*temporary admission carnet* means a document that is, or is of the same nature as, a carnet de passages en douane, relating to the presence in Australia of a vehicle registered in a foreign country.

## **Division 4                      Particular equivalently registered vehicles**

### **110      Vehicle registered in another State in name of defence force member or eligible family member**

- (1) This section applies to a vehicle if—
  - (a) the vehicle is equivalently registered under a corresponding law to this regulation in the name of—
    - (i) a defence force member; or
    - (ii) an eligible family member of a defence force member; and
  - (b) the defence force member starts residing in Queensland because of a transfer arranged by the Australian Defence Force.

- 
- (2) The vehicle may be used on a road if the vehicle—
- (a) carries and displays, in the way required by the corresponding law, all number plates it is required to carry and display under that law; and
  - (b) is insured under a contract of insurance made under a corresponding law to the *Motor Accident Insurance Act 1994* of the State in which the vehicle is equivalently registered.
- (3) Subsection (2) stops applying if the registration of the vehicle in effect under the corresponding law at the time of the transfer expires.
- (4) In this section—
- eligible family member*, of a defence force member, means a person who—
- (a) usually resides with the defence force member; and
  - (b) is entitled to be transferred with the defence force member at the expense of the Australian Defence Force.

## **Part 5**                      **Register of vehicles and number plates**

### **111 Chief executive must keep register**

The chief executive must keep a register of vehicles and number plates under this part.

### **112 Details for registered vehicles and registered dealer plates**

- (1) The register must contain the following details for each registered vehicle and registered dealer plate—
- (a) the registered operator's—
    - (i) name; and

[s 112]

---

- (ii) address, including any postal address;
- (b) the day the term of registration starts;
- (c) the day the term of registration expires;
- (d) any other information the chief executive considers appropriate in relation to the registration.

*Examples for paragraph (d)—*

For a registered vehicle—

- an odometer reading
- if the vehicle is a concessionally registered vehicle for which a concessional registration fee stated in schedule 2, item 14 was paid—pension details of the registered operator
- information about a written-off vehicle given to the chief executive by the Queensland Police Service, the police service of another State, a corresponding authority or a notifier under a corresponding law to this regulation

For a registered dealer plate—

- details of the motor dealer licence under the *Motor Dealers and Chattel Auctioneers Act 2014* held by the registered operator
- details about why the dealer plate is required for the registered operator's business

- (2) Also, the register must contain the following details for each registered vehicle—
  - (a) the vehicle's registration number;
  - (b) the following identifying details for the vehicle—
    - (i) the vehicle's VIN;
    - (ii) the body shape type of the vehicle;
    - (iii) the vehicle's colour;
    - (iv) the vehicle's seating capacity;
    - (v) number of cylinders in the vehicle's engine;
    - (vi) the engine number of the vehicle's engine;

- (vii) the fuel type of the vehicle's engine;
  - (viii) the vehicle's make and model;
  - (c) the vehicle's GVM;
  - (d) if the vehicle has a GCM—the GCM;
  - (e) the vehicle's garage address;
  - (f) the vehicle's purpose of use;
- Examples—*
- private use, farm use
  - (g) for a conditionally registered vehicle—
    - (i) the conditions for use applying to the vehicle stated in the conditional registration guideline; and
    - (ii) if the vehicle is a heavy vehicle—the conditions applying to the vehicle stated in the heavy vehicle standards exemption;
  - (h) for a category 2 vehicle—the configuration in which the vehicle is nominated to operate for the term of its registration;
  - (i) for a motorbike, other than a motorbike that is conditionally registered—whether the motorbike is a learner approved motorbike.
- (3) In addition, if a dealer plate is given for use on a trailer, the register must describe or identify the plate as a dealer plate given for use on a trailer.
- (4) The register must contain the details required under this section for each registered vehicle and registered dealer plate for a period of 2 years after the registration expires.

*Note—*

For when a term of registration for a vehicle expires, see section 30.

[s 113]

---

### **113 Notifiable information about written-off vehicles to be kept**

- (1) This section applies if notifiable information about a written-off vehicle is given to the chief executive under part 7, division 2, subdivision 2.
- (2) The chief executive must include the notifiable information for the written-off vehicle on the register, regardless of whether the written-off vehicle is, or has been, a registered vehicle.
- (3) If the vehicle is recorded as a repairable write-off in the register, the chief executive must amend the register to ensure the written-off vehicle is no longer recorded as a repairable write-off if—
  - (a) there is a written-off vehicle inspection report for the vehicle; or
  - (b) the vehicle is recorded in a register kept under a corresponding law to this regulation and there is, under the corresponding law, a report for the vehicle that is equivalent to a written-off vehicle inspection report for the vehicle.

### **114 Details for personalised number plates to be kept**

The register must contain the following information about a personalised number plate—

- (a) the number on the personalised number plate;
- (b) if the personalised number plate has been transferred to a person under section 135—the name and address, including any postal address, of the most recent transferee;
- (c) if the personalised number plate has been converted from another number plate under section 136—confirmation of the conversion;
- (d) if neither paragraph (b) nor (c) applies—information sufficient to identify the person to whom the personalised number plate was given under section 132.

---

## **115 Details for unregistered vehicle permits to be kept**

- (1) The register must contain the following details for each unregistered vehicle permit granted under section 74—
  - (a) the name and address, including any postal address, of the person to whom the permit is granted;
  - (b) the day the permit term starts;
  - (c) the day the permit term expires;
  - (d) the identifying details mentioned in section 112(2)(b) for the vehicle for which the permit is granted;
  - (e) details of the journey for which the permit is granted;
  - (f) the following details about the CTP insurance policy for the vehicle—
    - (i) the name of the insurer;
    - (ii) the date of the policy;
    - (iii) the insurance certificate number, if any, for the policy;
  - (g) if, under a vehicle law, another permit is required to move the vehicle—
    - (i) the type of permit required; and
    - (ii) the reference number, if any, for the permit;
  - (h) any other information the chief executive considers appropriate.
- (2) The register must contain the details required under subsection (1) for each unregistered vehicle permit for a period of 2 years after the permit expires.

## **116 Information on register not conclusive of title to registered vehicle**

Despite anything else in this regulation—

- (a) the chief executive is not required to ensure the person whose name is shown in the register as the registered

[s 117]

---

operator of a vehicle is a person who has title to the vehicle; and

- (b) the register is not intended to be a means by which the title to a registered vehicle may be conclusively established.

## **Part 6                      Number plates**

### **Division 1                  Number plates generally**

#### **117    Assigning registration numbers and giving number plates**

- (1) If the chief executive decides to grant a registration application for a vehicle under section 21(1)(b), the chief executive must—
  - (a) assign a registration number to the vehicle; and
  - (b) give the registered operator of the vehicle—
    - (i) if the vehicle is a motorbike, motorised mobility device, quad bike or trailer—1 number plate displaying the registration number for the vehicle; or
    - (ii) otherwise—2 number plates displaying the registration number for the vehicle.
- (2) However, subsection (1) does not apply if—
  - (a) the vehicle is a category 2 vehicle; and
  - (b) the vehicle is equivalently registered in the applicant's name; and
  - (c) a national heavy vehicle number plate has been given for the vehicle.
- (3) In this section—

---

*quad bike* means a 4-wheeled motor vehicle that is ridden in the same way as a 2-wheeled motor vehicle.

## 118 Position, visibility and legibility of number plates

- (1) The registered operator of a vehicle must ensure—
  - (a) if 2 number plates are given for the vehicle and the registered operator does not hold an approval under section 142A—
    - (i) 1 of the number plates is attached to the front of the vehicle; and
    - (ii) the other number plate is attached to the rear of the vehicle; or
  - (b) if 2 number plates are given for the vehicle and the registered operator holds an approval under section 142A—1 of the number plates is attached to the rear of the vehicle; or
  - (c) if only 1 number plate is given for the vehicle—the number plate is attached to the rear of the vehicle.

Maximum penalty—12 penalty units.

- (2) The registered operator must ensure each number plate is securely attached to the vehicle so that if the vehicle is on level ground—
  - (a) the number plate is—
    - (i) in an upright position parallel to the vehicle's axles; and
    - (ii) not more than 1.3m above ground level; and
  - (b) unless an accessory plate is also attached to the vehicle under section 140—the characters on the number plate are visible from 20m away at any point within an arc of 45° from the surface of the number plate above or to either side of the vehicle, as shown in—
    - (i) for a vehicle in relation to which subsection (1)(a) applies—figure 1 at the end of this paragraph; or

[s 118]

- (ii) for a vehicle in relation to which subsection (1)(b) applies—figure 2 at the end of this paragraph; and

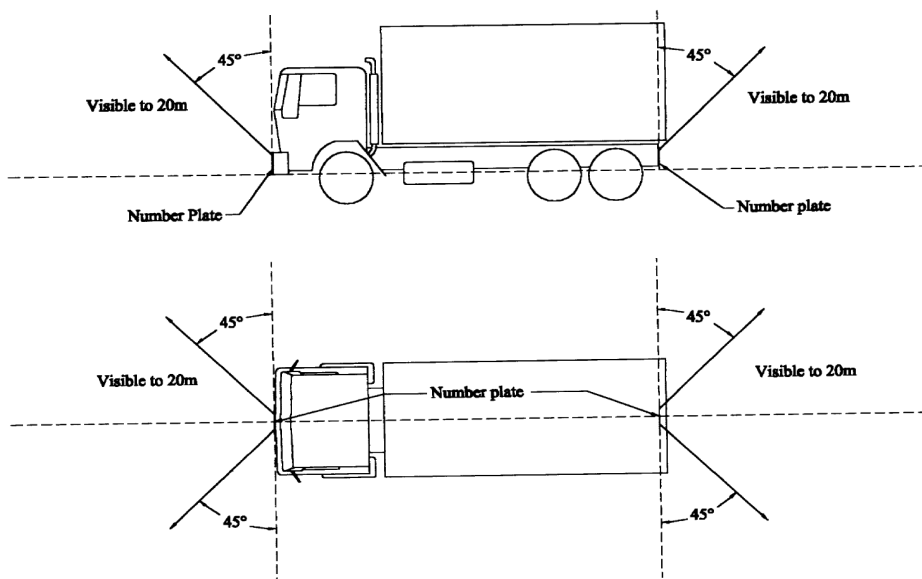
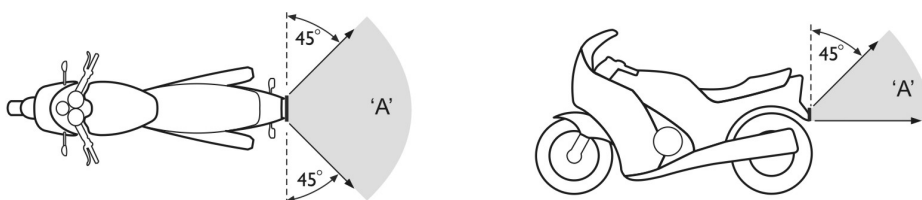

Figure 1—vehicle to which subsection (1)(a) applies



**Number plates must be clearly visible from 20 metres at all points within arcs 'A'**

Figure 2—vehicle to which subsection (1)(b) applies

- (c) any cover on the number plate—
  - (i) is clear, clean, untinted and flat over its entire surface; and
  - (ii) has no reflective or other characteristics that would prevent—

- (A) the successful operation of a photographic detection device; or
- (B) the number plate from being legible; and
- (d) the number plate is in a clearly legible condition, including being clearly legible from any position from which it is required to be visible under paragraph (b).

Maximum penalty—40 penalty units.

- (3) Characters on a number plate are taken not to be visible under subsection (2)(b) if a load on the vehicle obscures any part of the characters.
- (4) In this section—  
*number plate*—
  - (a) means a number plate or special plate; but
  - (b) does not include an accessory plate given under section 139 or 141.

## **119 Position, visibility and legibility requirements not contravened in particular circumstances**

- (1) The registered operator of a vehicle does not contravene section 118(2)(a) or (b) if—
  - (a) because of the vehicle’s construction, it is not practicable to attach a number plate to the vehicle under that section; and
  - (b) the registered operator attaches the number plate to the vehicle as nearly as practicable to the way required under that section.
- (2) Also, the registered operator of a vehicle (the *towing vehicle*) towing another vehicle (the *towed vehicle*) does not contravene section 118(2)(b) if the position for the rear number plate of the towing vehicle required under that subsection is obscured by the towed vehicle and—
  - (a) the towed vehicle—
    - (i) is registered or equivalently registered; and

[s 120]

---

- (ii) displays its rear number plate under section 118(2) or a corresponding law to that section; or
  - (b) each of the following applies—
    - (i) the towing vehicle is a tow truck;
    - (ii) the towed vehicle is not registered or equivalently registered;
    - (iii) the towed vehicle—
      - (A) displays the towing vehicle’s rear number plate under section 118(2); or
      - (B) displays an accessory plate for the towing vehicle under section 142; or
  - (c) each of the following applies—
    - (i) the towing vehicle is not a tow truck;
    - (ii) the towed vehicle is an exempt vehicle mentioned in schedule 1, item 1, 2 or 10;
    - (iii) the towed vehicle displays the towing vehicle’s rear number plate under section 118(2) or a corresponding law to that section.
- (3) If a vehicle’s number plates are removed and confiscated under the *Police Powers and Responsibilities Act 2000*, section 74H(2A), the registered operator of the vehicle does not contravene section 118(1) or (2) while the number plates are confiscated.

## **120 When registered operator must attach number plates**

The registered operator of a vehicle who is given a number plate for the vehicle by the chief executive under section 117(1)(b) must attach the number plate to the vehicle under this division within 24 hours after receiving the number plate.

Maximum penalty—12 penalty units.

*Note—*

However, see section 134 or 138 for when the registered operator of a vehicle must attach a special plate to the vehicle.

## **121 When number plate must not be attached to a vehicle**

A number plate, other than a dealer plate, must not be attached to a vehicle if—

- (a) the registration of the vehicle has been cancelled; or
- (b) it has been more than 3 months since the vehicle's registration expired and the registration has not been renewed.

*Note—*

See also section 211(h)(ii).

## **122 Number plates not legible because damaged or dirty**

- (1) This section applies if an authorised officer reasonably considers a vehicle's number plate is not legible because it is damaged or dirty.
- (2) The authorised officer may, by written notice given to the registered operator of, or a person in charge of, the vehicle, require the registered operator to—
  - (a) if the number plate is damaged—apply to the chief executive, within the period stated in the notice, for a replacement number plate under section 123; or
  - (b) otherwise—
    - (i) clean the number plate; and
    - (ii) bring the vehicle to the chief executive to be inspected within 14 days after the notice is given.
- (3) If the notice is given to a person other than the registered operator of the vehicle, the person must, within 48 hours after receiving the notice, give the notice to the registered operator, unless the person has a reasonable excuse.

Maximum penalty—6 penalty units.

[s 123]

---

- (4) The registered operator must comply with a notice given under subsection (2) unless the registered operator has a reasonable excuse.

Maximum penalty—20 penalty units.

- (5) Despite anything else in this regulation, a person who uses a vehicle, or permits a vehicle to be used, on a road without a required number plate attached to the vehicle under this regulation does not commit an offence if all of the following apply—
- (a) the number plate is damaged;
  - (b) an authorised officer has given the registered operator of the vehicle a written notice under subsection (2)(a);
  - (c) the damaged number plate and the written notice are being carried in the vehicle;
  - (d) the vehicle is being driven to a place for the purpose of applying, at the place, to the chief executive for a replacement number plate under section 123.

- (6) In this section—

*required number plate*, for a vehicle, means a number plate required under this regulation to be attached to the vehicle.

## **123 Damaged, destroyed, lost or stolen number plates**

- (1) This section applies if the registered operator of a vehicle becomes aware a number plate for the vehicle has been damaged, destroyed, lost or stolen.
- (2) The registered operator must—
- (a) apply to the chief executive for a replacement of the number plate; and

*Note—*

See part 9, division 2 for requirements for particular applications.

- (b) ensure the application is made within 14 days after becoming aware of the damage, destruction, loss or

theft, unless the registered operator has a reasonable excuse.

Maximum penalty—20 penalty units.

- (3) The application must—
- (a) be accompanied by the following—
    - (i) the fee stated in schedule 4, part 1 or 2 for replacing the number plate;
    - (ii) if the application is for the replacement of a damaged number plate—the damaged number plate;
    - (iii) if the application is for the replacement of a destroyed, lost or stolen number plate—a statement giving details of the destruction, loss or theft; and
- Note—*  
See part 9, division 3 for requirements for particular customer communications.
- (b) if the number plate being replaced is a special plate—state whether the application is for—
    - (i) a replacement special plate with the same combination of numbers or letters as the number plate being replaced; or
    - (ii) another number plate with a new combination of numbers or letters.
- (4) On receiving the application, the chief executive must—
- (a) record in the register—
    - (i) the day the application was received; and
    - (ii) the damage, destruction, loss or theft of the number plate; and
  - (b) give the registered operator—
    - (i) if the application is for a replacement special plate mentioned in subsection (3)(b)(i)—the replacement special plate applied for; or

[s 123]

---

- (ii) otherwise—another number plate with a new combination of numbers or letters.
- (5) If a number plate is replaced by a number plate with a new combination of numbers or letters, the chief executive must make available to the registered operator an updated registration certificate for the vehicle that contains the new combination.
- (6) Subsection (7) applies if—
- (a) the chief executive has not yet given the registered operator a replacement number plate under subsection (4)(b); and
  - (b) the registered operator is in possession of another number plate for the vehicle.
- (7) The registered operator must ensure the other number plate is attached to the rear of the vehicle.

Maximum penalty—12 penalty units.

- (8) When a replacement number plate is given under subsection (4)(b)—
- (a) the number plate being replaced stops being effective; and
  - (b) the replacement number plate becomes the current number plate for the vehicle.
- (9) If the registered operator recovers a lost or stolen number plate that has been replaced under subsection (4)(b), the registered operator must—
- (a) return the replaced number plate to the chief executive; and
  - (b) comply with paragraph (a) immediately, unless the operator has a reasonable excuse.

Maximum penalty—20 penalty units.

---

**123A Waiving fee for particular number plates damaged, destroyed, lost or stolen in particular circumstances**

- (1) This section applies to an application under section 123 for the replacement of a number plate for a vehicle.
- (2) The chief executive may waive the application fee mentioned in section 123(3)(a)(i) if the application is for the replacement of a number plate that was—
  - (a) damaged, destroyed or lost as a result of a person, other than the registered operator of the vehicle, committing an indictable offence that is a crime or misdemeanour; or
  - (b) stolen.
- (3) However, if the application is for the replacement of a special plate for a vehicle, subsection (2) applies only if the application is for another number plate that is not a special plate.

**124 Copied number plates**

- (1) This section applies if the registered operator of a vehicle becomes aware a number plate for the vehicle has been copied.
- (2) The registered operator may apply to the chief executive for a replacement number plate, other than a personalised number plate, for the vehicle.

*Note—*

See part 9, division 2 for requirements for particular applications.

- (3) The application must be accompanied by—
  - (a) the number plate that has been unlawfully copied; and
  - (b) a statement about the unlawful copying.

*Note—*

See part 9, division 3 for requirements for particular customer communications.

- (4) On receiving the application, the chief executive may—

[s 125]

---

- (a) record in the register—
    - (i) the day the application was received; and
    - (ii) details of the unlawful copying; and
  - (b) give a replacement number plate with a new combination of numbers or letters to the registered operator; and
  - (c) make available to the registered operator an updated registration certificate for the vehicle.
- (5) When the replacement number plate is given—
- (a) the replaced number plate stops being effective; and
  - (b) the replacement number plate becomes the current number plate for the vehicle.

## **125 Chief executive may require exchange of number plates**

- (1) This section applies if the chief executive—
- (a) considers any writing, word or image displayed on a number plate is obscene, indecent, contrary to the public interest or likely to cause offence to a reasonable person; or
  - (b) considers the number of a current number plate for a registered vehicle is, or appears to be, identical to the combination of numbers or letters of a number plate for another registered vehicle; or
  - (c) considers a number plate was given in error; or
  - (d) changes the specifications to which a number plate is manufactured; or
  - (e) considers any writing, word or image displayed on a number plate is likely to—
    - (i) infringe the intellectual property rights of a person other than the State; or
    - (ii) give rise to a cause of action for passing off or defamation; or

- 
- (iii) contravene the Australian Consumer Law (Queensland), section 18, 29 or 37.
- (2) The chief executive may, by written notice, require a person recorded in the register as the person who was given or who acquired the number plate to return the number plate (the *original plate*) to the chief executive, within the period stated in the notice, to be exchanged for another number plate.
- (3) The written notice must state the chief executive's reason for requesting the return of the original plate.
- (4) The person must comply with the notice unless—
- (a) the original plate has been lost, stolen or destroyed; and
  - (b) the person gives or has given the chief executive notice of the loss, theft or destruction.

*Note—*

See part 9, division 3 for requirements for particular customer communications.

Maximum penalty—20 penalty units.

- (5) On the return of the original plate—
- (a) the original plate stops being effective; and
  - (b) the chief executive must give the person a number plate, with a new combination of numbers or letters, to replace the original plate; and
  - (c) if the original plate was given for a vehicle—
    - (i) the replacement number plate becomes the current number plate for the vehicle; and
    - (ii) the chief executive must make available to the registered operator an updated registration certificate for the vehicle.
- (6) The chief executive must record in the register—
- (a) the exchange, if the original plate is—
    - (i) returned under this section; or

[s 126]

---

- (ii) delivered to an authorised officer under section 212(1)(d); or
  - (iii) removed and recovered by an authorised officer under section 212(5); or
- (b) if the person has given the chief executive notice of the loss, theft or destruction of the original plate—that the person has given the notice.

## **126 Chief executive may require return of number plates if term of registration expires**

- (1) This section applies if the term of registration for a vehicle expires.
- (2) The chief executive may, by written notice given to the last registered operator of the vehicle, require the registered operator to return the vehicle's number plates to the chief executive within 14 days after the notice is given (the *return period*).
- (3) The last registered operator must, within the return period—
  - (a) if the number plates have been lost, stolen or destroyed—give the chief executive notice of the loss, theft or destruction; or

*Note—*

See part 9, division 3 for requirements for particular customer communications.

- (b) otherwise—return the number plates to the chief executive.

Maximum penalty—20 penalty units.

## **127 Chief executive may require return of number plates for other reasons**

- (1) This section applies if the chief executive reasonably believes—

- 
- (a) a number plate is being used, or has been used, by a person in contravention of this regulation; or
  - (b) both of the following apply—
    - (i) a number plate has been given for a vehicle for which—
      - (A) the purpose of use recorded on the register is a limousine or taxi; and
      - (B) a licence under the *Transport Operations (Passenger Transport) Act 1994* given for the limousine or taxi is no longer in force;
    - (ii) a person is in possession of the number plate.
  - (2) The chief executive may, by written notice, require the person to return the number plate to the chief executive within 14 days after the notice is given (the *return period*).
  - (3) The written notice must—
    - (a) include the reasons for the request; and
    - (b) if the chief executive proposes to give a replacement number plate to a person under subsection (7)—state the proposal.
  - (4) The person must comply with the notice.  
Maximum penalty—20 penalty units.
  - (5) However, if the number plate has been lost, stolen or destroyed, the person does not contravene subsection (4) if the person gives the chief executive notice of the loss, theft or destruction within the return period.
- Note—*
- See part 9, division 3 for requirements for particular customer communications.
- (6) On receiving a number plate under subsection (4), the chief executive must record the return of the number plate in the register.
  - (7) If this section applies because of subsection (1)(b), the chief executive may give the person to whom the number plate was

[s 128]

---

given a replacement number plate that is not given as the number plate for a limousine or taxi.

- (8) If a replacement number plate is given under this section—
- (a) the number plate being replaced stops being effective; and
  - (b) the replacement number plate becomes the current number plate for the vehicle; and
  - (c) the chief executive must make available to the registered operator an updated registration certificate for the vehicle.

## **128 Who owns number plates**

- (1) A number plate given by the chief executive remains the property of the State.
- (2) However, if a national heavy vehicle number plate is given by the chief executive, the number plate remains the property of the State unless the vehicle to which the plate relates is equivalently registered.
- (3) Also, if a national heavy vehicle number plate is given in another State under a corresponding law to this regulation, the number plate becomes the property of the State when the vehicle to which the plate relates is registered under this regulation.
- (4) Subsection (1) applies even if, under section 133(1), the right to use the combination of numbers or letters on the number plate is the property of the person to whom the plate was given.

---

## **Division 2                      Special edition number plates**

### **129      Special edition number plates**

The chief executive may give a special edition number plate for a vehicle, other than a category 2 vehicle, on receiving an amount decided by the chief executive.

### **130      Application to replace number plate with special edition number plate**

- (1) The registered operator of a vehicle, other than a category 2 vehicle, may apply to the chief executive to replace each number plate for the vehicle with a special edition number plate.

*Note—*

See part 9, division 2 for requirements for particular applications.

- (2) The application must be accompanied by—
  - (a) each plate fee stated in schedule 4, part 2 relating the vehicle; and
  - (b) the amount mentioned in section 129 for the number plate; and
  - (c) the number plate previously given for the vehicle, unless the plate is a special plate.
- (3) On receiving the application, the chief executive may—
  - (a) give the registered operator a special edition number plate to replace the number plate previously given for the vehicle; and
  - (b) make available to the registered operator an updated registration certificate for the vehicle.
- (4) If a special edition number plate is given under subsection (3)(a)—
  - (a) the number plate previously given for the vehicle stops being effective; and

[s 131]

---

- (b) the special edition number plate becomes the current number plate for the vehicle.

## **Division 3                      National heavy vehicle number plates**

### **131      Application to replace number plate with national heavy vehicle number plate**

- (1) This section applies to a registered operator of a category 2 vehicle for which the current number plates (the *original number plates*) are not national heavy vehicle number plates.
- (2) The registered operator may apply to the chief executive to replace the original number plates with national heavy vehicle number plates.

*Note—*

See part 9, division 2 for requirements for particular applications.

- (3) The application must be accompanied by—
  - (a) the fee for replacing the original number plates stated in schedule 4, part 1; and
  - (b) if the original number plates are not special plates—the original number plates.
- (4) On receiving the application, the chief executive may—
  - (a) give the registered operator the national heavy vehicle number plates to replace the original number plates; and
  - (b) make available to the registered operator an updated registration certificate for the vehicle.
- (5) If national heavy vehicle number plates are given under subsection (4)(a)—
  - (a) the original number plates stop being effective; and
  - (b) the national heavy vehicle number plates become the current number plates for the vehicle.

---

## Division 4                      Personalised number plates

### 132      Personalised number plates given on application or sale

- (1) A person may apply to the chief executive for a number plate containing a combination of numbers or letters chosen by the person (a *personalised number plate*).

*Note—*

See part 9, division 2 for requirements for particular applications.

- (2) The application must be accompanied by the published fee for the personalised number plate.
- (3) The chief executive may, on receiving the application and published fee, give the personalised number plate to the person.
- (4) Also, the chief executive may give a personalised number plate to a person on a sale of the plate at public auction.
- (5) If the chief executive gives a person a personalised number plate under this section, the chief executive must—
- (a) assign to the person the combination of numbers or letters as the registration number for the personalised number plate; and
  - (b) record in the register—
    - (i) the assigned registration number; and
    - (ii) details sufficient to identify the person.
- (6) The chief executive must not give a person a personalised number plate whose combination of numbers or letters is identical, or appears to be identical, to the combination of numbers or letters of another current number plate.
- (7) In this section—

*published fee*, for a personalised number plate, means the fee stated for the plate on the website located at [www.ppq.com.au](http://www.ppq.com.au).

### **133 Using personalised number plates**

- (1) The right to use the combination of numbers or letters on a personalised number plate is the property of the person to whom the chief executive gives the plate.

*Note—*

See, however, section 128(1) and (4).

- (2) However, subsection (1) does not apply if—
- (a) the personalised number plate is surrendered to the chief executive for cancellation under subsection (3)(c); or
  - (b) the chief executive gives the person a written notice under section 125(2) or 127(2); or
  - (c) an authorised officer—
    - (i) asks a person to deliver the personalised number plate to the officer under section 212(1)(d); or
    - (ii) removes and recovers the personalised number plate from a vehicle under section 212(5) because it is required to be returned to the chief executive under section 125.
- (3) A personalised number plate may be—
- (a) kept without being attached to a vehicle; or
  - (b) attached to a vehicle under section 134; or
  - (c) surrendered to the chief executive for cancellation.

### **134 Attaching personalised number plates to vehicles**

- (1) A person who proposes to attach a personalised number plate to a vehicle must give the chief executive notice of the person's intention to do so.

*Note—*

See part 9, division 3 for requirements for particular customer communications.

- (2) On receiving the notice, the chief executive must—
- (a) approve the proposal; and

- 
- (b) record in the register the combination of numbers or letters appearing on the personalised number plate as the registration number for the vehicle; and
  - (c) make available to the registered operator of the vehicle an updated registration certificate for the vehicle.
- (3) A person—
- (a) must not attach the personalised number plate to the vehicle before the registered operator receives the updated registration certificate for the vehicle under subsection (2)(c); and
  - (b) must ensure the personalised number plate is attached to the vehicle within 24 hours after the registration certificate is received by the person.

Maximum penalty—20 penalty units.

### **135 Transferring personalised number plates**

- (1) A personalised number plate, including the right to use the combination of numbers or letters on the personalised number plate, is transferable.
- (2) A person to whom a personalised number plate is transferred, including a person administering a deceased estate, must—
  - (a) give the chief executive notice of the transfer; and

*Note—*  
See part 9, division 3 for requirements for particular customer communications.

  - (b) pay to the chief executive the fee stated in schedule 4, part 5 for giving the notice; and
  - (c) ensure the notice is given and the payment is made within 14 days after the transfer, unless the person has a reasonable excuse.

Maximum penalty—20 penalty units.

- (3) A person who transfers a personalised number plate to another person may give the chief executive notice of the transfer.

[s 136]

---

*Note—*

See part 9, division 3 for requirements for particular customer communications.

- (4) A notice given to the chief executive under subsection (2)(a) or (3) must state—
  - (a) the day of the transfer; and
  - (b) the name and address of the person to whom the personalised number plate has been transferred.
- (5) Subsection (6) applies if the chief executive—
  - (a) receives a notice and fee under subsection (2) or a notice under subsection (3); and
  - (b) is satisfied the information stated in the notice is correct.
- (6) The chief executive must—
  - (a) record in the register the day of the transfer; and
  - (b) replace, in the register, the name and address of the person transferring the personalised number plate with the name and address of the person to whom the personalised number plate has been transferred.
- (7) A person must not transfer a single personalised number plate that is 1 of a pair.

Maximum penalty—20 penalty units.
- (8) In this section—

**address** includes a postal address.

### **136 Converting number plate to personalised number plate**

- (1) A person may apply to the chief executive to convert a number plate, other than a national heavy vehicle number plate, to a personalised number plate.

*Note—*

See part 9, division 2 for requirements for particular applications.

- (2) The application must be accompanied by the conversion fee for the number plate.

- 
- (3) The chief executive may—
- (a) grant the application; and
  - (b) give the personalised number plate to the applicant.

*Note—*

For requirements for attaching the personalised number plate to a vehicle, see section 134.

- (4) In this section—

*conversion fee*, for a number plate, means the fee stated, on the website located at [www.ppq.com.au](http://www.ppq.com.au), for converting the plate to a personalised number plate.

## Division 5 Customised number plates

### 137 Customising number plates

- (1) A person may apply to the chief executive to customise a number plate if the number plate is—
- (a) a number plate attached to a registered vehicle of which the person is a registered operator; or
  - (b) a number plate that has been cancelled.

*Note—*

See part 9, division 2 for requirements for particular applications.

- (2) The application must be accompanied by the fee stated in schedule 4, part 5 for the application.
- (3) The chief executive may grant the application if the chief executive considers the number plate is suitable to be customised.
- (4) Without limiting subsection (3), in deciding whether the number plate is suitable to be customised, the chief executive may have regard to whether—
- (a) another number plate has already been customised in the way proposed in the application; and

[s 138]

---

- (b) the combination of numbers or letters appearing on the number plate is—
  - (i) in a format that is no longer used by the chief executive for number plates given under this part; or
  - (ii) likely, in the chief executive’s opinion, to be confused with the combination of numbers or letters appearing on another number plate; or
  - (iii) obscene, indecent, contrary to the public interest or likely to cause offence to a reasonable person.
- (5) If the chief executive grants the application, the number plate is a ***customised number plate***.
- (6) A customised number plate may be—
  - (a) kept without being attached to a vehicle; or
  - (b) attached to a vehicle under section 138; or
  - (c) surrendered to the chief executive for cancellation.

### **138 Attaching customised number plates to vehicles**

- (1) A person who proposes to attach a customised number plate to a vehicle must give the chief executive notice of the person’s intention to do so.

*Note—*

See part 9, division 3 for requirements for particular customer communications.

- (2) On receiving the notice, the chief executive must—
  - (a) approve the proposal; and
  - (b) record in the register the combination of numbers or letters appearing on the customised number plate as the registration number for the vehicle; and
  - (c) make available to the registered operator of the vehicle an updated registration certificate for the vehicle.
- (3) The person—

- (a) must not attach the customised number plate to the vehicle before the chief executive approves the proposal under subsection (2)(a); and
- (b) must ensure the customised number plate is attached to the vehicle within 24 hours after the registration certificate is received by the person.

Maximum penalty—20 penalty units.

## Division 6                      Accessory plates

### 139      **Applying for accessory plates for vehicles other than tow trucks**

- (1) The registered operator of a vehicle other than a tow truck may apply to the chief executive for a number plate displaying the registration number of the vehicle for attaching to the front or rear of an accessory that is attached to the vehicle.

*Note—*

See part 9, division 2 for requirements for particular applications.

- (2) The application must—
  - (a) state the registration number for the vehicle; and
  - (b) be accompanied by the fee stated in schedule 4, part 1 or 2 for the application.
- (3) On receiving the application and fee, the chief executive must give the number plate to the registered operator.
- (4) If the chief executive grants the application, the number plate is an *accessory plate* for the vehicle.

### 140      **Attaching accessory plates to vehicles other than tow trucks**

- (1) If a person attaches an accessory plate for a vehicle, other than a tow truck, to the front of the vehicle, the plate must be attached—

[s 141]

---

- (a) at the front of the accessory in relation to which the accessory plate was given; and
- (b) in a way that allows the accessory plate to be legible from a distance of at least 20m from the front of the accessory.

Maximum penalty—12 penalty units.

- (2) If a person attaches an accessory plate for a vehicle, other than a tow truck, to the rear of the vehicle, the plate must be attached—
  - (a) at the rear of the accessory in relation to which the accessory plate was given; and
  - (b) in a way that allows the accessory plate to be legible from a distance of at least 20m from the rear of the accessory.

Maximum penalty—12 penalty units.

## **141 Applying for accessory plates for tow trucks**

- (1) The registered operator of a tow truck may apply to the chief executive for a number plate, displaying the registration number of the tow truck, to be attached to the rearmost end of each unregistered vehicle to be towed by the tow truck.

*Note—*

See part 9, division 2 for requirements for particular applications.

- (2) The application must be accompanied by the fee stated in schedule 4, part 1 or 2 for the application.
- (3) On receiving the application and fee, the chief executive must give the accessory plate to the registered operator.
- (4) If the chief executive grants the application, the number plate is an *accessory plate* for the tow truck.

## **142 Attaching accessory plates for tow trucks**

A person who attaches an accessory plate to an unregistered vehicle to be towed by a tow truck must attach the plate—

- (a) to the rearmost end of the unregistered vehicle, as towed; and
- (b) in a way that is as nearly as practicable to the way a number plate would be required to be attached to that end of the vehicle were it a registered vehicle.

*Note—*

See also sections 118 and 119.

Maximum penalty—12 penalty units.

## **Division 6A                      Approval for modified number of number plates**

### **142A    Application for approval to modify number of number plates**

- (1) This section applies if 2 number plates are given to a registered operator of—
  - (a) a conditionally registered motorised golf buggy; or
  - (b) another conditionally registered vehicle with limited access registration.
- (2) The registered operator may apply to the chief executive for approval to attach only 1 of the number plates to the vehicle and to attach that number plate to the rear of the vehicle.

*Note—*

See part 9, division 2 for requirements for particular applications.

- (3) The chief executive must, after considering the application—
  - (a) grant the application; or
  - (b) refuse the application.
- (4) In making a decision about the application, the chief executive must have regard to—
  - (a) the type of vehicle and construction of the vehicle; and

[s 143]

---

- (b) the reason why a number plate can not be attached to the front of the vehicle; and
  - (c) the location in which the vehicle will be used; and
  - (d) whether granting the application is likely to—
    - (i) endanger public safety; or
    - (ii) hinder or prevent the enforcement of compliance with the Act in relation to the use of the vehicle.
- (5) If the chief executive grants the application, the chief executive must give the registered operator written notice of the approval.

## **Part 7                      Written-off vehicles**

### **Division 1                Classification and use of written-off vehicles**

#### **143    Vehicle assessed as total loss to be classified as statutory write-off or repairable write-off**

- (1) This section applies if either of the following assesses a notifiable vehicle for the purpose of giving notifiable information about the vehicle under this regulation—
- (a) a notifier;
  - (b) a person who assists a notifier in determining whether a vehicle is a written-off vehicle.
- (2) The notifier or person must classify the vehicle as either—
- (a) if the vehicle is a total loss because of corrosion, or damage that satisfies the statutory write-off assessment criteria for the vehicle—a statutory write-off; or
  - (b) otherwise—a repairable write-off.

Maximum penalty—50 penalty units.

---

## 144 Offence to use written-off vehicle on road

- (1) A person must not use a vehicle, or permit a vehicle to be used, on a road if the vehicle is recorded in a vehicle register as a written-off vehicle.

Maximum penalty—20 penalty units.

- (2) However, if the vehicle is a registered vehicle that is a repairable write-off, the person does not commit an offence against subsection (1) if—
- (a) the vehicle is recorded in a vehicle register as a repairable write-off that has been repaired; or
  - (b) both of the following apply—
    - (i) the person drives or tows the vehicle—
      - (A) to a place mentioned in subsection (3); or
      - (B) for the testing mentioned in subsection (4);
    - (ii) the driving, towing or testing is necessary for, or reasonably connected with, changing a vehicle register so the vehicle is no longer recorded as a repairable write-off; or
  - (c) the person is acting in accordance with an approval given by the chief executive for the vehicle.

*Note—*

The chief executive may give the approval verbally or in writing.

- (3) Each of the following is a place for subsection (2)(b)(i)(A)—
- (a) an AIS, or departmental inspection site, if the vehicle is driven or towed to the AIS or site for inspection to obtain an inspection certificate for the vehicle;
  - (b) a written-off vehicle inspection site, if—
    - (i) a current inspection certificate is in effect for the vehicle; and
    - (ii) the vehicle is driven or towed to the site for the purpose of obtaining a written-off vehicle inspection report;

[s 144]

---

- (c) the vehicle's garage address, if an inspection certificate is in effect for the vehicle;
- (d) another place at which a person may inspect or investigate the vehicle—
  - (i) to assess whether the vehicle complies with the *Transport Operations (Road Use Management—Vehicle Standards and Safety) Regulation 2021*; or
  - (ii) for a purpose relating to identifying the vehicle.

*Examples—*

- a place for inspection by an authorised officer or the Queensland Police Service
  - a place for obtaining a gas certificate
  - a place for having an identifying number stamped
- (4) The testing for subsection (2)(b)(i)(B) is testing to confirm the safe operation of the vehicle as part of an inspection mentioned in subsection (3)(a).
- (5) In this section—

***repairable write-off*** includes a vehicle that is, under a corresponding law to this regulation, equivalent to a repairable write-off.

***vehicle register*** means—

- (a) the register; or
- (b) another register, kept under a corresponding law to this regulation, that is equivalent to the register.

***written-off vehicle*** includes a vehicle that is, under a corresponding law to this regulation, equivalent to a written-off vehicle.

---

## **Division 2                    Information about written-off vehicles**

### **Subdivision 1            Interpretation**

#### **145    Definitions for division**

In this division—

*registered operator* includes a person in whose name the vehicle is equivalently registered.

*responsible person*, for a notifiable vehicle, means—

- (a) if the vehicle is an unregistered vehicle—the owner of the vehicle; or
- (b) otherwise—the registered operator of the vehicle.

### **Subdivision 2            Obligations to give information about written-off vehicles**

#### **146    Obligation of insurers to report written-off vehicles**

- (1) This section applies if an insurer, in the course of the insurer's insurance business in Queensland, assesses a notifiable vehicle as a total loss, regardless of whether the vehicle is—
  - (a) registered; or
  - (b) equivalently registered; or
  - (c) in Queensland.
- (2) The insurer must give the chief executive the notifiable information for the vehicle before the earlier of the following happens—
  - (a) the expiry of 7 days after the insurer makes a final decision for a claim in relation to the vehicle;
  - (b) the insurer sells or otherwise disposes of—

[s 147]

---

- (i) the vehicle; or
- (ii) any part of the vehicle that has a chassis number or VIN.

Maximum penalty—50 penalty units.

#### **147 Obligation of self-insurers to report written-off vehicles**

- (1) This section applies if—
  - (a) a self-insurer resides, or has a registered office, in Queensland; and
  - (b) the self-insurer assesses a notifiable vehicle as a total loss, whether or not the vehicle is in Queensland; and
  - (c) either—
    - (i) the self-insurer is the registered operator of the vehicle; or
    - (ii) the vehicle is owned by the self-insurer and is not registered or equivalently registered.
- (2) The self-insurer must give the chief executive the notifiable information for the vehicle before the earlier of the following happens—
  - (a) the expiry of 7 days after the assessment is finalised;
  - (b) the self-insurer sells or otherwise disposes of—
    - (i) the vehicle; or
    - (ii) any part of the vehicle that has a chassis number or VIN.

Maximum penalty—50 penalty units.

#### **148 Obligation of loss adjusters to report written-off vehicles**

- (1) This section applies if a loss adjuster, in the course of the adjuster's business, assesses as a total loss—
  - (a) a notifiable vehicle that is registered, whether or not the vehicle is in Queensland; or

- 
- (b) a notifiable vehicle in Queensland that is not registered or equivalently registered.
  - (2) However, this section does not apply to the extent the loss adjuster is, in the course of the adjuster's business, giving advice to an insurer, auctioneer or dealer about a matter mentioned in subsection (1)(a) or (b).
  - (3) The loss adjuster must give the chief executive the notifiable information for the vehicle within 7 days after finalising the assessment.

Maximum penalty—50 penalty units.

#### **149 Obligation of dealers and auctioneers to report written-off vehicles**

- (1) This section applies if a person, in the course of the person's business as a dealer or auctioneer, takes possession of a notifiable vehicle that is a total loss.
- (2) The person must give the chief executive the notifiable information for the vehicle before the earlier of the following happens—
  - (a) the expiry of 7 days after the person takes possession of the vehicle;
  - (b) the person sells or otherwise disposes of—
    - (i) the vehicle; or
    - (ii) any part of the vehicle that has a chassis number or VIN.

Maximum penalty—50 penalty units.

- (3) However, the person need not give the chief executive the notifiable information if—
  - (a) the person has searched the register or arranged for the register to be searched; and
  - (b) the search result shows that someone else has already given the notifiable information to the chief executive.
- (4) In this section—

*possession* includes custody or control.

**150 Obligation of auto parts dismantlers to report written-off vehicles**

- (1) This section applies if a person, in the course of the person's business as an auto parts dismantler, assesses either of the following as a total loss—
  - (a) a notifiable vehicle that is registered or equivalently registered;
  - (b) a notifiable vehicle in Queensland that is not registered or equivalently registered.
- (2) The person must give the chief executive the notifiable information for the vehicle before the earlier of the following happens—
  - (a) the expiry of 7 days after the person takes possession of the vehicle;
  - (b) the person—
    - (i) demolishes or dismantles the vehicle; or
    - (ii) sells or otherwise disposes of the vehicle; or
    - (iii) sells or otherwise disposes of any part of the vehicle that has a chassis number or VIN.

Maximum penalty—50 penalty units.

- (3) However, the person need not give the chief executive the notifiable information if—
  - (a) the person does not demolish or dismantle the notifiable vehicle; and
  - (b) someone else has already given the notifiable information to the chief executive.

---

**151 Obligation of registered operators and owners of unregistered vehicles to give chief executive notifiable information for written-off vehicles**

- (1) This section applies if—
- (a) a person, other than a self-insurer, proposes to sell or otherwise dispose of a notifiable vehicle, or a part of a notifiable vehicle that has an identifying number; and
  - (b) the vehicle is a total loss; and
  - (c) either—
    - (i) the person is the registered operator of the vehicle; or
    - (ii) all of the following apply—
      - (A) the vehicle is an unregistered vehicle;
      - (B) the person is the owner of the vehicle;
      - (C) the vehicle is in Queensland.
- (2) The person must give the chief executive the notifiable information for the vehicle, other than whether the vehicle is a repairable write-off or a statutory write-off, before the earlier of the following happens—
- (a) the person sells or otherwise disposes of the vehicle;
  - (b) the person sells or otherwise disposes of any part of the vehicle that has a chassis number or VIN.

Maximum penalty—10 penalty units.

*Note—*

See part 9, division 3 for requirements for particular customer communications.

- (3) However, the person need not give the chief executive the notifiable information if someone else has already given the information to the chief executive.
- (4) On receiving notifiable information under subsection (2), the chief executive is taken to have been notified that the vehicle is a repairable write-off unless—

[s 152]

---

- (a) someone else has already given notifiable information for the vehicle to the chief executive; and
- (b) the notifiable information indicates the vehicle is a statutory write-off.

**152 Notifier may change notifiable information previously given**

- (1) This section applies if—
  - (a) a notifier has given notifiable information for a vehicle to the chief executive; and
  - (b) the notifier becomes aware that details of the notifiable information have changed; and
  - (c) the vehicle—
    - (i) has not been repaired; and
    - (ii) has not left the notifier’s possession since the notifier gave the notifiable information to the chief executive.
- (2) The notifier must, within 7 days after becoming aware of the change of details, give notice of the change to the chief executive.

Maximum penalty—20 penalty units.

*Note—*

See part 9, division 3 for requirements for particular customer communications.

- (3) On receiving the notice, the chief executive may record the change of details in the register.

**153 Notifier may apply to correct error in notifiable information previously given**

- (1) A notifier may apply to the chief executive for approval to correct a clerical or technical error in notifiable information the notifier has previously given the chief executive.

*Note—*

See part 9, division 2 for requirements for particular applications.

- (2) The application must—
  - (a) include the reasons for the application; and
  - (b) be accompanied by written evidence, to the satisfaction of the chief executive, of the error.
- (3) On receiving the application, the chief executive may record the correction of the error in the register.

#### **154 Offence to give false or misleading notifiable information**

A notifier must not knowingly or recklessly give notifiable information for a vehicle to the chief executive that is false or misleading in a material particular.

Maximum penalty—80 penalty units.

#### **155 Requirement to notify chief executive of repair of written-off vehicle**

- (1) This section applies if—
  - (a) a notifier is required to give notifiable information for a written-off vehicle to the chief executive under this subdivision; and
  - (b) the notifier repairs the written-off vehicle.
- (2) The notifier must, within 7 days after the repair, give notice of the repair to the chief executive.

Maximum penalty—50 penalty units.

#### **156 Requirement to give chief executive other information**

- (1) This section applies if—
  - (a) a notifier is required to give notifiable information for a written-off vehicle to the chief executive under this subdivision; and

[s 157]

---

- (b) the chief executive considers other information about the written-off vehicle is required to maintain the integrity of information about written-off vehicles kept by the chief executive in the register.
- (2) The chief executive may require the notifier to give the chief executive the other information.
- (3) The notifier must comply with the requirement unless the notifier has a reasonable excuse.

Maximum penalty—20 penalty units.

### **157 Notifiers' obligation to inform responsible persons for notifiable vehicles**

- (1) This section applies if—
  - (a) a notifier gives notifiable information for a notifiable vehicle to the chief executive under this subdivision; and
  - (b) the notifier is not the responsible person for the vehicle.
- (2) Within 7 days after the notifier gives the notifiable information to the chief executive, the notifier must give the responsible person for the vehicle written notice that—
  - (a) the notifier has given the notifiable information for the vehicle to the chief executive; and
  - (b) the vehicle is—
    - (i) if the vehicle is a repairable write-off—a repairable write-off that can be registered only if it passes a written-off vehicle inspection; or
    - (ii) if the vehicle is a statutory write-off—a statutory write-off that can not be registered.

Maximum penalty—10 penalty units.

---

## **Subdivision 3      Labels for written-off vehicles**

### **158      Specifications for labels to be used by notifiers**

The chief executive may, by notice published on the department's website, approve specifications for a label to be attached to a notifiable vehicle by a notifier under section 159.

### **159      Notifiers' obligation to attach labels to written-off vehicles**

- (1) This section applies if a notifier gives notifiable information for a notifiable vehicle to the chief executive under subdivision 2.
- (2) On giving the notifiable information, the notifier must attach a label to the vehicle that—
  - (a) complies with the specifications for the label approved by the chief executive under section 158; and
  - (b) states the vehicle is—
    - (i) if the vehicle is a repairable write-off—a repairable write-off that can be registered only if it passes a written-off vehicle inspection; or
    - (ii) if the vehicle is a statutory write-off—a statutory write-off that can not be registered.

Maximum penalty—30 penalty units.

- (3) The label must be attached to the vehicle in a conspicuous position so it is clearly visible from outside the vehicle.

*Examples of positions that are not conspicuous—*

a back seat, a vehicle's floor

- (4) However, if it is not reasonably practicable for the notifier to attach the label to the vehicle the notifier must, within 7 days after giving the notifiable information to the chief executive, give the responsible person for the vehicle—
  - (a) a label that complies with subsection (2)(a) and (b) for the vehicle; and

[s 160]

---

- (b) a notice in the approved form about the label.

*Example of when it is not reasonably practicable for a notifier to attach a label to a written-off vehicle—*

A notifiable vehicle has been assessed by the notifier to be a written-off vehicle based on photographic evidence, or a report, prepared by a loss adjuster who has assessed the vehicle at a remote location.

Maximum penalty—30 penalty units.

**160 Chief executive must give label for written-off vehicle to person who gives notifiable information under s 151**

- (1) This section applies if a person gives the chief executive notifiable information for a vehicle under section 151(2).
- (2) On receiving the notifiable information, the chief executive must give the person a label for the vehicle that states—
- (a) the vehicle is a written-off vehicle; and
- (b) any other information the chief executive considers appropriate.

**161 Responsible person must attach label to written-off vehicle**

- (1) This section applies if the responsible person for a notifiable vehicle receives a label for the vehicle from—
- (a) a notifier under section 159(4)(a); or
- (b) the chief executive under section 160(2).
- (2) Within 24 hours after receiving the label, the responsible person must attach the label to the vehicle in a conspicuous position so it is clearly visible from outside the vehicle.

*Examples of positions that are not conspicuous—*

a back seat, a vehicle's floor

Maximum penalty—30 penalty units.

## **162 Offence to remove written-off vehicle label**

A person must not remove a label attached to a vehicle under this subdivision while the vehicle is recorded in the register as a written-off vehicle, unless the person has a reasonable excuse.

Maximum penalty—30 penalty units.

## **Subdivision 4 Audits**

### **163 Auditing of notifiers**

- (1) The chief executive may audit the operations of a notifier.
- (2) However, the chief executive may audit the operations only to the extent they relate to the obligations of the notifier as a giver of notifiable information about written-off vehicles under subdivision 2.
- (3) The notifier must, for the purpose of allowing the chief executive to conduct the audit, give the chief executive, at all reasonable times, full and free access to all documents and property belonging to, in the custody of, or under the control of, the notifier to the extent the document or property is relevant to the audit.

Maximum penalty—20 penalty units.

### **164 Identification of contravention in audit report**

- (1) This section applies if a report for an audit of a notifier's operations under section 163 identifies a contravention of subdivision 2 by the notifier.
- (2) The notifier must pay the reasonable costs of conducting the audit and compiling the audit report.
- (3) The chief executive may, by written notice given to the notifier—
  - (a) direct the notifier to—

[s 165]

---

- (i) rectify the contravention; or
  - (ii) ensure the contravention does not happen again; and
- (b) require the notifier to give the chief executive, within 14 days after the date of the notice, a notice (a ***rectification notice***) stating the action the notifier has taken to comply with the direction.

*Note—*

See part 9, division 3 for requirements for particular customer communications.

- (4) The notifier must comply with the requirement mentioned in subsection (3)(b), unless the notifier has a reasonable excuse.

Maximum penalty—20 penalty units.

- (5) In a proceeding against the notifier for an offence against this regulation, other than an offence against subsection (4), neither the rectification notice, nor the fact that the notifier gave the rectification notice, can be used in evidence against the notifier.
- (6) The costs payable by the notifier under subsection (2) may be recovered by the chief executive as a debt owing to the State.

## **Division 3                      Approvals for written-off vehicle inspections**

### **165      Application for inspection approval**

- (1) A person may apply to the chief executive for an approval to—
- (a) perform written-off vehicle inspections; or
  - (b) supervise the day-to-day running of written-off vehicle inspections for another person.

*Note—*

See part 9, division 2 for requirements for particular applications.

- (2) An approval to do a thing mentioned in subsection (1)(a) or (b) is an *inspection approval*.
- (3) Subject to section 195, the chief executive must consider and decide the application within 28 days after receiving it.

## 166 Deciding application

- (1) After considering the application, the chief executive must decide to—
  - (a) grant the inspection approval; or
  - (b) refuse the inspection approval.
- (2) The chief executive may grant the inspection approval only if the chief executive is satisfied, having regard to the applicant's qualifications, experience and criminal history, that the applicant is a suitable person to hold the approval.
- (3) A person who, under this section, is granted an inspection approval mentioned in section 165(1)(a) is an *approved written-off vehicle examiner*.
- (4) A person who, under this section, is granted an inspection approval mentioned in section 165(1)(b) is an *approved written-off vehicle nominee*.
- (5) An inspection approval may be granted on conditions the chief executive considers appropriate, including—
  - (a) for an approval of a person as an approved written-off vehicle examiner—
    - (i) a condition that the examiner may only perform written-off vehicle inspections while employed or otherwise engaged by a person contracted by the chief executive to operate a written-off vehicle inspection site; and
    - (ii) conditions about the way the examiner is to perform written-off vehicle inspections; or
  - (b) for an approval of a person as an approved written-off vehicle nominee—

[s 167]

---

- (i) a condition that the nominee may only supervise the day-to-day running of written-off vehicle inspections while employed or otherwise engaged by a person contracted by the chief executive to operate a written-off vehicle inspection site; and
- (ii) conditions about the way the nominee is to supervise the day-to-day running of written-off vehicle inspections.

### **167 Notice of decision**

- (1) The chief executive must give the applicant written notice of the decision.
- (2) If the decision is to grant the inspection approval on conditions, or to refuse the approval, the notice must state—
  - (a) the conditions or the reason for the refusal; and
  - (b) that the applicant may ask for the decision to be reviewed under section 213.

### **168 Inspection approval prescribed for Act, ss 17B and 18**

For the Act—

- (a) an inspection approval is prescribed for sections 17B(2) and 18(1)(c)(ii); and
- (b) the chief executive is authorised for section 17B(2) to refuse to grant or renew an inspection approval under that section.

---

## **Division 4                      Offences relating to written-off vehicle inspections**

### **169      Only approved written-off vehicle examiner may perform written-off vehicle inspection**

A person must not perform, or purport to perform, a written-off vehicle inspection unless the person is an approved written-off vehicle examiner.

Maximum penalty—80 penalty units.

### **170      Only approved written-off vehicle nominee may supervise written-off vehicle inspection**

A person must not supervise, or purport to supervise, the running of a written-off vehicle inspection unless the person is an approved written-off vehicle nominee.

Maximum penalty—80 penalty units.

### **171      Not complying with conditions of inspection approval**

A person holding an inspection approval granted on conditions must comply with the conditions.

Maximum penalty—80 penalty units.

### **172      False or misleading written-off vehicle inspection report**

A person must not knowingly or recklessly give another person a written-off vehicle inspection report that is false or misleading in a material particular.

Maximum penalty—80 penalty units.

### **173      Operating place as written-off vehicle inspection site**

A person must not operate, or purport to operate, a place as a written-off vehicle inspection site unless the person is

[s 174]

---

contracted by the chief executive to operate the place as a written-off vehicle inspection site.

Maximum penalty—80 penalty units.

**174 Performing written-off vehicle inspection at place other than written-off vehicle inspection site**

An approved written-off vehicle examiner must not perform a written-off vehicle inspection at a place unless the place is operated by a person contracted by the chief executive to operate the place as a written-off vehicle inspection site.

Maximum penalty—80 penalty units.

**175 Supervising written-off vehicle inspection at place other than written-off vehicle inspection site**

An approved written-off vehicle nominee must not supervise the running of a written-off vehicle inspection at a place unless the place is operated by a person contracted by the chief executive to operate the place as a written-off vehicle inspection site.

Maximum penalty—80 penalty units.

**176 False advertising or holding out**

A person must not falsely advertise or hold out that a particular place is a place where written-off vehicle inspections may be performed.

Maximum penalty—80 penalty units.

---

## Part 8 Measures for natural disasters and droughts

### Division 1 Natural disasters

#### 177 Application of division

This division applies in relation to the registration, or renewal of registration, of an eligible vehicle.

#### 178 Definitions for division

In this division—

*disaster assistance area* means an area for which a disaster assistance arrangement is activated.

*disaster assistance arrangement* means either of the following disaster relief and recovery arrangements administered by the State—

- (a) the arrangements known as the ‘Disaster Recovery Funding Arrangements’;
- (b) the arrangements known as the ‘State Disaster Relief Arrangements’.

*eligible vehicle* see section 179(2).

*natural disaster relief measure* means any of the following—

- (a) registration, or renewal of registration, of a vehicle under section 181;
- (b) an exemption from paying a surcharge or fee in relation to a registration application or renewal application for a vehicle under section 182;
- (c) a deferral of the day by which a renewal application for a vehicle must be made under section 183.

*natural disaster relief notice* see section 180(1).

## **179 When natural disaster relief measures may be relied on**

- (1) A natural disaster relief measure may be relied on for a vehicle if—
  - (a) the postcode for the vehicle’s garage address is the postcode of an area that is wholly or partly within the area for which the natural disaster relief measures are activated; and
  - (b) while the natural disaster relief measure is in effect—
    - (i) a registration application is made for the vehicle; or
    - (ii) a notice is given to a person under section 31 about renewing the vehicle’s registration; or
    - (iii) the vehicle’s registration expires.
- (2) A vehicle for which a natural disaster relief measure may be relied on is an *eligible vehicle*.

## **180 Natural disaster relief notice**

- (1) The chief executive may, by notice published on a Queensland Government website (a *natural disaster relief notice*), activate the natural disaster relief measures for all or part of a disaster assistance area.
- (2) The natural disaster relief notice must state—
  - (a) the part of the disaster assistance area for which the natural disaster relief measures are activated; and
  - (b) the period the notice has effect.
- (3) In this section—

***Queensland Government website*** means a website with a URL that contains ‘qld.gov.au’, other than a website of a local government.

---

**181 Reduced term of registration or renewal of registration**

- (1) An eligible vehicle may be registered, or an eligible vehicle's registration may be renewed, for a term of 3 months.
- (2) This section applies in addition to section 28.

**182 Exemption from surcharge for reduced term of registration or administrative fee for late payment**

Despite any other provision of this regulation, an applicant for registration, or renewal of registration, of an eligible vehicle is exempt from paying the following in relation to the application—

- (a) a surcharge stated in schedule 4;
- (b) if the application is for renewal of registration of the vehicle—an administrative fee stated in schedule 4, part 3.

**183 Seasonal registration—deferral of day by which renewal application must be made**

- (1) This section applies in relation to an eligible vehicle that is a seasonal heavy vehicle.
- (2) The chief executive may, on or before the expiry day for the eligible vehicle's registration, defer the day by which a renewal application for the vehicle must be made for a period of not longer than 2 years.

**Division 2 Droughts**

**184 Application of division**

This division applies in relation to the registration, or renewal of registration, of an eligible vehicle during the period—

- (a) starting on the day a drought declaration is made for the drought-declared area in which, or the drought-declared

[s 185]

---

property at which, the eligible vehicle has its garage address; and

- (b) ending 1 year after the day the area or property stopped being a drought-declared area or drought-declared property.

## 185 Definitions for division

In this division—

***drought declaration*** means an official acknowledgement by the State that an area or property is drought-stricken.

***drought-declared area*** means an area for which a drought declaration is in force.

***drought-declared property*** means a property for which a drought declaration is in force.

***eligible vehicle*** see section 186.

***supporting material***, for an eligible vehicle, means—

- (a) if the vehicle's garage address is in a drought-declared area or at a drought-declared property—written evidence the garage address for the vehicle is in the area or at the property; or
- (b) if the vehicle's garage address is in an area or at a property that has stopped being a drought-declared area or drought-declared property—a written notice stating the eligible vehicle's garage address is in the area or at the property.

## 186 Meaning of ***eligible vehicle***

- (1) In this division, a vehicle is an ***eligible vehicle*** if—
  - (a) the vehicle's purpose of use is recorded in the register or nominated in a registration application as private purposes or farming purposes; and
  - (b) either—

- 
- (i) the vehicle's garage address is in a drought-declared area or at a drought-declared property; or
  - (ii) both of the following apply—
    - (A) the vehicle's garage address is in a place that was previously a drought-declared area or at a drought-declared property;
    - (B) a drought relief measure for the vehicle was used while the place was in a drought-declared area or at a drought-declared property.
- (2) However, none of the following vehicles is an *eligible vehicle*—
- (a) a vehicle that is conditionally registered;
  - (b) a farm plate vehicle;
  - (c) a vehicle for which—
    - (i) the registered operator is not a primary producer; or
    - (ii) a registration application in relation to which a drought relief measure applies is made, if the applicant is not a primary producer.
- (3) In this section—
- drought relief measure* means any of the following—
- (a) registration or renewal of registration of a vehicle under section 187;
  - (b) an exemption from paying a surcharge or fee in relation to a registration application or renewal application for a vehicle under section 188;
  - (c) for a seasonal heavy vehicle—a deferral of the day by which a renewal application for a vehicle must be made under section 190.

[s 187]

---

**187 Reduced term of registration or renewal of registration**

- (1) An eligible vehicle may be registered, or the vehicle's registration may be renewed, for a term of 3 months.
- (2) This section applies in addition to section 28.

**188 Exemption from surcharge for reduced term of registration or from administrative fee for late payment**

- (1) An applicant for registration, or renewal of registration, of an eligible vehicle is exempt from paying the following in relation to the application—
  - (a) a surcharge stated in schedule 4;
  - (b) for a renewal application for a vehicle—an administrative fee stated in schedule 4, part 3.
- (2) This section applies despite any other provision of this regulation.

**189 Supporting material must be given**

- (1) A registration application or renewal application for an eligible vehicle made in reliance on section 187 or 188 (the *current application*) must be accompanied by the supporting material for the vehicle.
- (2) However, subsection (1) does not apply if—
  - (a) the applicant has relied on section 187 or 188 for another registration application or renewal application for the eligible vehicle within 1 year before the current application is made; and
  - (b) the applicant has complied with subsection (1) in relation to the other application.
- (3) This section applies in addition to sections 20(1) and 33(1).

---

**190 Seasonal registration—deferral of day by which renewal application must be made**

- (1) This section applies in relation to an eligible vehicle that is a seasonal heavy vehicle.
- (2) The chief executive may, on or before the expiry day for the eligible vehicle's registration, defer the day by which a renewal application for the vehicle must be made for a period of not longer than 2 years.
- (3) However, the registration may only be renewed during the second year of the period if the registered operator gives the chief executive the supporting material for the eligible vehicle.

**Division 3                      Transport of fodder for disaster or drought-affected primary producers**

**191 Transport of fodder by primary producer for another primary producer**

- (1) This section applies to a primary producer who is the registered operator of a concessionally registered heavy primary production vehicle.
- (2) The primary producer may use the vehicle, or permit the vehicle to be used, other than as a heavy primary production vehicle, if—
  - (a) the use is for the transport of fodder for another primary producer; and
  - (b) the requirements under subsection (3) are satisfied.
- (3) For subsection (2)(b), the requirements are—
  - (a) both of the following apply—
    - (i) the other primary producer has been granted disaster relief financial assistance;

[s 192]

---

- (ii) the fodder is transported within 1 year after the day the other primary producer is granted the disaster relief financial assistance; or
- (b) the other primary producer is the registered operator of a vehicle whose garage address is—
  - (i) in a drought-declared area or at a drought-declared property; or
  - (ii) in an area that has been a drought-declared area within 1 year before the fodder is transported; or
  - (iii) at a property that has been a drought-declared property within 1 year before the fodder is transported.
- (4) However, subsection (2) does not apply if the transport of the fodder is done for reward or under a commercial arrangement.
- (5) In this section—

*disaster relief financial assistance* means financial assistance granted by the State or Commonwealth because of a disaster.

*drought-declared area* see section 185.

*drought-declared property* see section 185.

*reward* does not include an expense incurred in transporting fodder.

## **Part 9**                      **Requirements for particular applications and customer communications**

### **Division 1**                **Preliminary**

#### **192**    **Definitions for part**

In this part—

**application** means an application required or permitted to be made to the chief executive under this regulation.

**customer communication**—

- (a) means any of the following—
  - (i) a notice, however described, required or permitted to be given by a person to the chief executive under a provision of this regulation;
  - (ii) a direction under section 31(1)(a);
  - (iii) a statement under section 45(2), 49(3), 123(3)(a)(iii) or 124(3)(b);
  - (iv) the giving of notifiable information under part 7, division 2, subdivision 2;
  - (v) a request for an extract from the register under section 202(1)(a); but
- (b) does not include the giving of supporting material for an eligible vehicle under section 189 or 190.

**information** includes a document.

## Division 2 Particular applications

### 193 Chief executive may publish notice about applications

- (1) The chief executive may, by publishing a notice on the department's website—
  - (a) approve a way in which an application may be made; or  
*Examples of ways—*
    - orally, by electronic communication or by another form of communication
  - (b) require stated information to be included in, or to accompany, an application.
- (2) A notice under subsection (1)(a) may include requirements for making an application in the approved way.

[s 194]

---

- (3) A notice under subsection (1)(b) may only require information that is reasonably necessary for—
- (a) the chief executive to decide the application; or
  - (b) another purpose related to the application or the thing being applied for.

*Examples of information that is not reasonably necessary—*

- irrelevant personal information
  - relevant personal information if the provision of the information would be excessively intrusive to personal privacy
- (4) Subsection (1) applies whether or not there is an approved form for making the application.

## **194 How applications must be made**

- (1) An application must be made in 1 of the following ways—
- (a) in the approved form for the application;
  - (b) in the approved way under section 193(1)(a) for making the application;
  - (c) if there is no approved form and no approved way for making the application—in writing.
- (2) If an application under section 19 or part 3, division 3 is made by a person (the **agent**) on behalf of an applicant, the application must be accompanied by evidence, satisfactory to the chief executive, of—
- (a) the agent’s identity; and
  - (b) the applicant’s identity; and
  - (c) the agent’s authority to act as agent for the applicant in making the application.
- (3) An application must include, or be accompanied by, any information required for the application under section 193(1)(b).

- (4) Subsection (3) does not limit or otherwise affect another provision of this regulation that requires an application to include, or be accompanied by, particular information.

## **195 Chief executive may request further information**

- (1) The chief executive may, by written notice given to an applicant, ask for further information the chief executive reasonably needs to decide the application.
- (2) The notice—
- (a) must state—
    - (i) the information required; and
    - (ii) the time, no earlier than 28 days after the notice is given, by which the information is required to be given to the chief executive; and
    - (iii) the chief executive may cancel the application if the applicant does not comply with the notice; and
  - (b) may state a way in which the information must be given.
- (3) If the notice does not state a way in which the information must be given, the applicant must give the information in writing.
- (4) If the applicant does not comply with the notice, the chief executive may give the applicant a written notice cancelling the application.
- (5) The cancellation takes effect on the day the notice cancelling the application is given to the applicant or a later day stated in the notice.

## **Division 3                      Particular customer communications**

### **196 Chief executive may publish notice about customer communications**

- (1) The chief executive may, by publishing a notice on the department's website—
  - (a) approve a way in which a customer communication may be given or made; or  
*Examples of ways—*
    - orally, by electronic communication or by another form of communication
  - (b) require stated information to be included in, or to accompany, a customer communication.
- (2) A notice under subsection (1)(a) may include requirements for giving or making a customer communication in the approved way.
- (3) Subsection (1) applies whether or not there is an approved form for giving or making the customer communication.

### **197 How customer communications must be given or made**

- (1) A customer communication must be given or made in 1 of the following ways—
  - (a) in the approved form for the customer communication;
  - (b) in the approved way under section 196(1)(a) for giving or making the customer communication;
  - (c) if there is no approved form and no approved way for giving or making the customer communication—in writing.
- (2) A customer communication must include, or be accompanied by, any information required for the communication under section 196(1)(b).

- (3) Subsection (2) does not limit or otherwise affect another provision of this regulation that requires a customer communication to include, or be accompanied by, particular information.

## **Part 10 Use and release of information**

### **Division 1 Use of information from register**

#### **198 Definition for division**

In this division—

*prescribed information*, for a vehicle, means—

- (a) the name and address of the vehicle's registered operator; and
- (b) if the registered operator's postal address or telephone number is contained in the register—the postal address or telephone number.

#### **199 Use of prescribed information for contacting registered operator about moving or removing vehicle**

- (1) This section applies if, under section 51G of the Act, the chief executive—
- (a) proposes to move or remove a vehicle; or
  - (b) is moving or removing a vehicle; or
  - (c) has moved or removed a vehicle.
- (2) If the vehicle is registered, the chief executive may use prescribed information about the vehicle to contact the registered operator of the vehicle about the movement or removal, or proposed movement or removal, of the vehicle.
- (3) If the vehicle is not, but has previously been, registered, the chief executive may use prescribed information about the

[s 200]

---

vehicle to contact the last registered operator of the vehicle about the movement or removal, or proposed movement or removal, of the vehicle.

## 200 Use of information for contacting registered operator about recovery of cost of damage

- (1) This section applies if a person—
  - (a) is the registered operator of a vehicle; and
  - (b) is liable under the *Transport Infrastructure Act 1994*, section 48(2) to pay an amount to the chief executive as a result of a person’s operation of the vehicle.
- (2) The chief executive may use prescribed information about the vehicle to contact the person in relation to the liability mentioned in subsection (1)(b).

## Division 2 Release of information from register

### 201 Definitions for division

In this division—

***authorised statutory entity*** means—

- (a) an entity established under an Act of Queensland, or a law of another State or the Commonwealth, that enforces a law about vehicles or the parking of vehicles in an area under its control; or

*Example—*

a local government

- (b) an entity that has lawful access, under an Act or an arrangement approved by the chief executive, to details kept by the chief executive in the register.

***give***, in relation to information, includes allowing a person to obtain the information.

***insolvency entity*** means an entity exercising powers—

- (a) under the *Bankruptcy Act 1966* (Cwlth) in relation to bankruptcy; or
- (b) under the provisions of the Corporations Act relating to external administration.

***interstate register*** means a register kept by another State under a corresponding law to this regulation.

***NEVDIS*** means the database known as the ‘National exchange of vehicle and driver information system’ that—

- (a) is operated under an arrangement among the State and other States; and
- (b) contains information about vehicles and drivers from registers kept by the States participating in the arrangement.

***personal information***, about a vehicle’s current or previous registered operator, means—

- (a) the registered operator’s name, address, email address or telephone number; and
- (b) if there is a current postal address for the registered operator—the postal address; and
- (c) any other information about the registered operator if the registered operator’s identity is apparent, or can reasonably be ascertained, from the information.

***safety recall agency*** means a vehicle manufacturer conducting a national vehicle safety recall program, to the extent the manufacturer requires details from the register to identify the registered operators of particular vehicles for the program.

***vehicle-related information***, for a vehicle, means information about the vehicle from the register, or from an interstate register that is available to the chief executive through NEVDIS, but does not include—

- (a) for a vehicle currently recorded in the register or interstate register as a written-off vehicle—
  - (i) personal information about a current or previous registered operator of the vehicle; or

[s 202]

---

- (ii) information about a notifier that has given notifiable information for the vehicle; or
  - (iii) information about the location, or severity, of damage to the vehicle; or
- (b) for another vehicle—personal information about a current or previous registered operator of the vehicle.

## **202 Giving extracts from register to eligible persons**

- (1) The chief executive may give an extract from the register about a vehicle to an eligible person, or a person acting for the eligible person, if the person does the following—
- (a) gives the chief executive a request for the extract;
- Note—*  
See part 9, division 3 for requirements for particular customer communications.
- (b) if the eligible person is an authorised statutory entity—pays the chief executive the amount, if any, the chief executive decides is reasonable, having regard to how and why the extract is being given to the person;
  - (c) if the eligible person is a person other than an authorised statutory entity or safety recall agency—pays the chief executive the fee stated in schedule 4, part 5 for giving the extract.
- (2) For subsection (1)(b), the amount decided by the chief executive must not be more than the amount of the fee stated in schedule 4, part 5 for giving the extract to an eligible person other than an authorised statutory entity or safety recall agency.
- (3) The extract may include personal information about the vehicle’s current or previous registered operator.
- (4) The chief executive may give the extract on conditions about the use or disclosure of information in the extract.

- 
- (5) The eligible person, or the person acting for the eligible person, must not use or disclose information in the extract other than under the conditions mentioned in subsection (4).

Maximum penalty—20 penalty units.

- (6) In this section—

***eligible person***, for an extract about a vehicle, means—

- (a) a person who proposes to start, or has started, litigation; or
- (b) an authorised statutory entity; or
- (c) the registered operator of the vehicle; or
- (d) a safety recall agency; or
- (e) a person who has the written consent of the registered operator of the vehicle to request the extract; or
- (f) an insolvency entity.

***litigation*** means a proceeding, or a proposed proceeding, in a court for which information in the register about a particular vehicle is, or may be, relevant, but only if—

- (a) the proceeding is about—
  - (i) an incident involving the vehicle; or
  - (ii) the bankruptcy or possible bankruptcy of the registered operator of the vehicle; or
  - (iii) the application, or the possible application, to the registered operator of the vehicle, of the provisions of the Corporations Act relating to external administration; or
  - (iv) fraudulent activities of the registered operator of the vehicle; or
- (b) the proceeding is before the Family Court of Australia and involves the registered operator of the vehicle; or
- (c) in the course of the proceeding, the court decides information about the registered operator of the vehicle

[s 203]

---

is required, including, for example, to help to finalise the proceeding.

### **203 Public access providers may allow client users to obtain extracts from register**

- (1) A public access provider may allow a client user to obtain, using online computer access, an extract from the register about a vehicle if the client user—
  - (a) pays the public access provider—
    - (i) if the client user is an authorised statutory entity—the amount, if any, the chief executive decides is reasonable having regard to how and why the extract is being obtained by the client user; or
    - (ii) otherwise—the fee stated in schedule 4, part 5 for obtaining the extract; and
  - (b) obtains the extract only in the circumstances approved by the chief executive for obtaining the extract.
- (2) For subsection (1)(a)(i), the amount payable must not be more than the amount of the fee stated in schedule 4, part 5 for obtaining the extract.
- (3) The extract may include personal information about the vehicle’s current or previous registered operator.
- (4) The chief executive may impose conditions about the use or disclosure of information in the extract.
- (5) The client user must not use or disclose information in the extract other than in accordance with the conditions mentioned in subsection (4).

Maximum penalty—20 penalty units.

- (6) In this section—

*client user*, of a public access provider, means an authorised statutory entity, lawyer, insolvency entity or insurance entity who—

- 
- (a) has entered into a written agreement with the chief executive about obtaining, using online computer access, extracts from the register about vehicles; and
  - (b) is approved by the chief executive as a suitable entity to obtain the extracts under the agreement.

***insurance entity*** means—

- (a) a body corporate that—
  - (i) is authorised under the *Insurance Act 1973* (Cwlth) to carry on insurance business; and
  - (ii) issues insurance policies for vehicles that, under this regulation or a corresponding law to this regulation, must be registered to be used on a road; or
- (b) an agent of a body corporate mentioned in paragraph (a) that provides, on behalf of the body corporate, a claims handling and settling service relating to insurance claims for vehicles.

***public access provider*** means—

- (a) the chief executive; or
- (b) a person who has entered into an agreement with the chief executive to provide online computer access to the register to entities approved by the chief executive.

## **204 Giving extracts from register to tolling entities**

- (1) The chief executive may, under a written arrangement entered into between the chief executive and a toll road operator or local government tollway operator, give an extract from the register about a vehicle to—
  - (a) the operator; or
  - (b) a person acting for the operator.
- (2) Without limiting subsection (1), the chief executive may, under a written arrangement entered into between the chief

[s 204]

---

executive and a local government, give an extract from an available register about a vehicle to—

- (a) the local government; or
  - (b) a person acting for the local government.
- (3) However, the chief executive may give an extract under subsection (1) or (2) only for the purpose of the local government enforcing a tolling offence committed in relation to a local government tollway in the local government's area.
- (4) An extract given under subsection (1) or (2) may include personal information about the vehicle's current or previous registered operator.
- (5) A written arrangement mentioned in subsection (1) or (2) must—
- (a) include conditions imposed by the chief executive on—
    - (i) giving the extract; and
    - (ii) the use and disclosure of the information in the extract; and
  - (b) provide for payment to the chief executive of the reasonable amount decided by the chief executive for giving the extract.
- (6) The tolling entity, or a person acting for the tolling entity, to whom the extract is given must not use or disclose the information in the extract other than in accordance with the conditions mentioned in subsection (5)(a).

Maximum penalty—20 penalty units.

- (7) However, subsection (6) applies to a person acting for a tolling entity only if the person is advised of the conditions before or at the time the extract is given to the person.
- (8) In this section—

*available register* means—

- (a) the register; or

- (b) an interstate register that is available to the chief executive through NEVDIS.

**local government tollway** see the *Transport Infrastructure Act 1994*, section 105GA(5).

**local government tollway operator** see the *Transport Infrastructure Act 1994*, section 105B.

**tolling entity** means—

- (a) a toll road operator; or  
(b) a local government tollway operator; or  
(c) a local government with which the chief executive has entered into an arrangement mentioned in subsection (2).

**tolling offence** means an offence against the *Transport Infrastructure Act 1994*, section 105ZH(7), 105ZJ(4) or 105ZK(7).

**toll road operator** see the *Transport Infrastructure Act 1994*, section 92.

## 205 Giving information to entities that maintain NEVDIS

- (1) The chief executive may, for the NEVDIS arrangement, give an extract from the register about a vehicle to the entity that maintains NEVDIS.
- (2) The extract may include personal information about the vehicle's current or previous registered operator.
- (3) In this section—

**NEVDIS arrangement** means the arrangement mentioned in section 201, definition *NEVDIS*, paragraph (a).

## 206 Information provider may give vehicle-related information

- (1) An information provider may give a person vehicle-related information about a vehicle if—

[s 206]

---

- (a) the person pays the information provider the amount or fee payable under subsection (2); and
  - (b) the vehicle-related information is given to the person only in the circumstances approved by the chief executive in relation to the giving of the information.
- (2) For subsection (1)(a), the amount or fee payable is—
- (a) if the information provider is the chief executive—
    - (i) the amount, of not more than the amount of the fee stated in schedule 4, part 5 for giving the vehicle-related information, that the chief executive decides is reasonable having regard to how and why the vehicle-related information is given to the person; or
    - (ii) otherwise—the fee stated in schedule 4, part 5 for giving the vehicle-related information.
  - (b) if the information provider is a person other than the chief executive—the fee stated in schedule 4, part 5 for giving the vehicle-related information.
- (3) Subsection (1)(a) does not apply to a person in relation to an extract or other information given to the person under section 204, 205 or 207.
- (4) The chief executive may impose conditions about the use or disclosure of vehicle-related information about a vehicle given to a person under subsection (1).
- (5) The person must not use or disclose the information other than in accordance with the conditions mentioned in subsection (4).

Maximum penalty—20 penalty units.

- (6) However, subsection (5) applies to the person only if the person is advised of the conditions before or at the time the extract is given to the person.

- (7) In this section—

***information provider*** means—

- (a) the chief executive;
- (b) a person who has entered into an agreement with the chief executive for the provision by the person of vehicle-related information about a vehicle to other persons.

## 207 Chief executive may give vehicle-related information to particular persons

- (1) The chief executive may give vehicle-related information about a vehicle to a person if the chief executive is satisfied—
  - (a) the information will inform the person about whether the vehicle is, or is not—
    - (i) a registered vehicle; or
    - (ii) a high-powered vehicle; or
    - (iii) a learner approved motorbike; or
  - (b) the information will inform the person about the vehicle’s purpose of use; or
  - (c) the person requires the information to determine whether an inspection certificate is in effect for the vehicle; or
  - (d) the person is a specified person who requires the information for the purpose of identifying a vehicle to which an inspection certificate or inspection report under the *Transport Operations (Road Use Management—Vehicle Standards and Safety) Regulation 2021* relates; or
  - (e) the person is an approved person who requires the information to perform a function of an approved person.
- (2) In this section—

**approved person** see the *Transport Operations (Road Use Management—Accreditation and Other Provisions) Regulation 2015*, schedule 7.



- (ii) that is equivalent to a registration certificate, number plate or permit given under this regulation.

**209 Things that purport to be, but are not, registration certificates, number plates or permits**

A person must not make, sell or have in the person's possession anything that purports to be, but is not, a registration certificate, number plate or permit unless the person has a reasonable excuse.

Maximum penalty—40 penalty units.

**210 Altering or defacing registration certificates, number plates or permits**

A person must not alter or deface a registration certificate, number plate or permit unless the person has a reasonable excuse.

Maximum penalty—40 penalty units.

**211 Using, or permitting use of, vehicle for which registration certificate, number plate or permit altered etc.**

- (1) A person must not, unless the person has a reasonable excuse, use a vehicle, or permit a vehicle to be used, on a road if—
- (a) a registration certificate, number plate or permit for the vehicle has been materially altered; or
  - (b) a registration certificate, number plate or permit for the vehicle has been defaced; or
  - (c) a number plate for the vehicle has been repainted in any way; or

*Example—*

paint used to repair stone chips or other damage

- (d) any writing, mark, or colour on a registration certificate, number plate or permit for the vehicle is not clearly legible; or

- (e) a number plate or permit attached to the vehicle was given or granted for another vehicle; or
- (f) a number plate attached to the vehicle has been recorded in the register as having been cancelled, lost, stolen, destroyed or damaged; or
- (g) a number plate required under this regulation to be attached to the vehicle is not attached to the vehicle; or
- (h) a number plate is attached to the vehicle—
  - (i) in a way other than as required under this regulation; or
  - (ii) in contravention of section 121; or
- (i) a permit required under this regulation to be attached to the vehicle—
  - (i) is not attached to the vehicle; or
  - (ii) is attached to the vehicle in a way other than as required under this regulation.

Maximum penalty—

- (a) if the vehicle is used in the commission of a type 1 vehicle related offence—40 penalty units; or
  - (b) otherwise—20 penalty units.
- (2) In this section—

*type 1 vehicle related offence* see the *Police Powers and Responsibilities Act 2000*, section 69A(1).

## **212 Requirement to remove unlawful registration item**

- (1) An authorised officer may ask a person in charge of a vehicle to remove from the vehicle, and deliver to the officer, a registration item for the vehicle if the authorised officer reasonably believes—
  - (a) under this regulation, the use of the vehicle on a road is prohibited; or

- (b) the registration item was not lawfully given for the vehicle; or
  - (c) the registration item is recorded in the register as having been cancelled, lost, stolen, destroyed or damaged; or
  - (d) the registration item is a number plate required to be returned to the chief executive under section 125.
- (2) The person must comply with the request unless the person has a reasonable excuse.

Maximum penalty—20 penalty units.

- (3) Subsection (4) applies if the authorised officer requests the removal of a registration item—
- (a) under subsection (1)(a) on the basis that section 211(h)(ii) applies; or
  - (b) under subsection (1)(b), (c) or (d).
- (4) The authorised officer must advise the person that if the person does not comply with the request at the time it is made the officer may, under subsection (5), remove and recover the number plates attached to the vehicle.
- (5) If the person does not comply with the request, the authorised officer may remove and recover the number plates attached to the vehicle.
- (6) In this section—

**registration item**, for a vehicle, means—

- (a) any of the following given or granted in relation to the vehicle—
  - (i) a registration certificate;
  - (ii) a number plate;
  - (iii) a permit;
  - (iv) an inspection certificate; or
- (b) if the vehicle is a conditionally registered vehicle to which the conditional registration guideline applies—a

[s 213]

---

document required to be carried in the vehicle under the guideline; or

- (c) an item purporting to be an item mentioned in paragraph (a) or (b).

## Part 12                      Review of decisions

### 213      Review of decisions not provided for under Act, ch 4

Sections 65 and 65A of the Act apply to the following decisions (each a *relevant decision*) as if a reference to an original decision in section 65 of the Act were a reference to a relevant decision—

- (a) a decision to refuse an authorisation to use an unregistered vehicle under section 14(1)(a);
- (b) a decision to refuse a registration application or renewal application for a vehicle under section 22 or 23, unless—
  - (i) the vehicle is a statutory write-off; or
  - (ii) the decision is made under section 23(b); or
  - (iii) section 25(3) applies to the decision;

*Note—*

For a renewal application for a vehicle, see section 34.

- (c) a decision to refuse to record in the register a transfer of a registered vehicle's registration under section 50;
- (d) a decision to refuse a registration application for a dealer plate under section 79(1)(a);
- (e) a decision to refuse a renewal application for a dealer plate under section 87(1)(a);
- (f) a decision to refuse an inspection approval under section 166(1)(b);
- (g) a decision to impose a condition on an inspection approval under section 166(5);

- (h) a decision to refuse an application for approval of a learner approved motorbike under section 217(1)(b);
- (i) a decision to reassess a fee under section 228;
- (j) a decision to reassess a registration fee under section 245, including a decision to require the payment of a fee balance under section 246.

## Part 13                      Miscellaneous

### Division 1                      Approval of motorbikes as learner approved motorbikes

#### 214      Definition for division

In this division—

**LAM information**, for a motorbike, means the following information about the motorbike—

- (a) engine capacity;
- (b) maximum engine power;
- (c) tare mass.

#### 215      Meaning of **LAM test report**

- (1) A **LAM test report** is a document showing the results of 1 or more tests conducted on a motorbike to work out the LAM information for an application for approval of the motorbike under section 216.

*Example of LAM test report—*

a printout of the results of a test from a vehicle testing facility and a test by a weighbridge

- (2) A LAM test report must contain the following information about a test conducted on a motorbike—

[s 216]

---

- (a) the name and address of the entity that conducted the test;

*Example of an entity that conducts a test—*

an entity that operates a vehicle testing facility or a weighbridge

- (b) the date of the test;
- (c) the LAM information for the motorbike;
- (d) details about the measuring system used to conduct the test.

*Example of a measuring system used to conduct a test—*

a dynamometer or a similar measuring system that is designed to measure power produced by an engine

## **216 Application for approval of motorbike as a learner approved motorbike**

- (1) A person may apply to the chief executive for approval of a production motorbike as a learner approved motorbike.

*Note—*

See part 9, division 2 for requirements for particular applications.

- (2) However, the person may not apply if the production motorbike is a vehicle to which the conditional registration guideline applies.
- (3) The application must—
  - (a) be accompanied by—
    - (i) a copy of a document published by the motorbike’s manufacturer showing the LAM information for the motorbike; or
    - (ii) if a copy of the document mentioned in subparagraph (i) is unavailable—a LAM test report; and
  - (b) include the following information, to the extent it is available to the applicant, about the motorbike—
    - (i) make and model;

- (ii) year of manufacture;
- (iii) engine number;
- (iv) VIN or chassis number.

## **217 Deciding application**

- (1) The chief executive must, after considering the application—
  - (a) grant the application; or
  - (b) refuse the application.
- (2) The chief executive may grant the application only if the chief executive is satisfied the production motorbike—
  - (a) is fitted with either—
    - (i) an electric motor; or
    - (ii) an internal-combustion engine with an engine capacity of not more than 660mL; and
  - (b) has a power-to-weight ratio of not more than 150kW per tonne; and
  - (c) has not been modified other than for an allowable modification.
- (3) If the chief executive decides to grant the application, the chief executive must—
  - (a) record the motorbike in the register as a learner approved motorbike; and
  - (b) record the motorbike in the LAM list.
- (4) If the chief executive decides to refuse the application, the chief executive must give the applicant written notice of the refusal.
- (5) The notice must state—
  - (a) the decision to refuse; and
  - (b) the reasons for the refusal; and
  - (c) that the decision may be reviewed under section 213.

[s 218]

---

(6) In this section—

***allowable modification***, for a learner approved motorbike, means—

(a) a modification that—

- (i) is designed to enable a person with a physical impairment to ride the motorbike; and
- (ii) does not increase the maximum engine power of the motorbike; and
- (iii) is a compliant modification of the learner approved motorbike under the *Transport Operations (Road Use Management—Vehicle Standards and Safety) Regulation 2021*, section 17; or

*Example—*

modification of the motorbike’s foot controls to enable the driver to operate the motorbike by hand controls

(b) a modification of the motorbike’s seating capacity that is a compliant modification of the learner approved motorbike under the *Transport Operations (Road Use Management—Vehicle Standards and Safety) Regulation 2021*, section 17.

## **218 Chief executive must keep list of learner approved motorbikes**

(1) The chief executive must keep a list of learner approved motorbikes (the ***LAM list***).

*Editor’s note—*

A copy of the LAM list is available on the department’s website.

(2) The LAM list—

- (a) must record a production motorbike for which the chief executive grants an application under section 217(1); and
- (b) may record another motorbike if the chief executive is satisfied the motorbike complies with section 217(2)(a), (b) and (c).

- 
- (3) A motorbike that is recorded in the LAM list is a *learner approved motorbike*.

## Division 2            Other provisions

### 219    Sale of unregistered vehicles by dealers

- (1) A dealer must not deliver an unregistered vehicle to a purchaser on the sale of the vehicle unless—
- (a) the vehicle is delivered to another dealer; or
  - (b) a registration application has been made, but not yet decided, for the vehicle.

Maximum penalty—40 penalty units.

- (2) However, a dealer does not contravene subsection (1) if the dealer obtains a written statement from the purchaser that—
- (a) the vehicle is not to be used on a road; or
  - (b) the vehicle's garage address will not be in Queensland.
- (3) The dealer must keep a statement received under subsection (2) for at least 1 year after the day the vehicle is delivered to the purchaser.

Maximum penalty—8 penalty units.

- (4) In this section—

*dealer* does not include the holder of a licence or other authority under a corresponding law to the *Motor Dealers and Chattel Auctioneers Act 2014* that is equivalent to a motor dealers licence under that Act.

## **Part 14 Fees and related matters**

### **Division 1 Fees generally**

#### **220 Fees**

- (1) The registration fees for a category 1 vehicle are the fees stated for the vehicle in schedule 2.
- (2) The registration fees for a category 2 vehicle are the fees stated for the vehicle in schedule 3.
- (3) The registration fee for a category 2 vehicle stated in schedule 3, part 1 or 2 is the total of—
  - (a) the amount of the road use component stated for the vehicle; and
  - (b) the amount of the regulatory component stated for the vehicle.
- (4) Other fees payable under this regulation are stated in schedule 4.
- (5) A fee payable under a relevant provision that relates to the registration of a vehicle or a dealer plate for a term is—
  - (a) if the fee is expressed as a number of fee units—the fee in force on 1 July in the financial year in which the term starts; or
  - (b) if the fee is expressed in dollars—the fee stated in the relevant provision for the financial year in which the term starts.
- (6) For subsection (5), if the fee is for the renewal of registration of a vehicle or a dealer plate, the term is taken to start on the same day it would have started for the purpose of working out when the renewed term expires under section 36 or 89 for the vehicle or dealer plate.
- (7) Also, if the term of a vehicle’s registration is less than 1 year, a registration fee or traffic improvement fee that relates to the

registration of the vehicle is to be adjusted in proportion to the number of days in the term.

(8) In this section—

*relevant provision* means schedule 2 or 3 or schedule 4, part 3 or 4.

## **220A Rounding of amounts expressed as numbers of fee units**

- (1) This section applies for working out the amount of a fee expressed in this regulation as a number of fee units.
- (2) For the purpose of the *Acts Interpretation Act 1954*, section 48C(3), the amount is to be rounded to the nearest multiple of 5 cents (rounding one-half upwards).

*Example—*

If a fee were 35 fee units and the value of a fee unit were \$1.015, the number of dollars obtained by multiplying 35 by \$1.015 would be \$35.525. Because \$35.525 is halfway between \$35.50 and \$35.55, it is rounded upwards, so the amount of the fee would be \$35.55.

## **221 Charging categories**

- (1) If a category 2 vehicle falls within 2 or more charging categories stated in schedule 3, part 1 or 2, the registration fee for the vehicle is the higher, or highest, of the fees that could apply to the vehicle.
- (2) For applying schedule 3, the following vehicles are taken to be 1 trailer—
  - (a) a converter dolly and a semitrailer, when used together;
  - (b) a low loader dolly and a low loader, when used together.
- (3) For applying schedule 3 to a vehicle, other than a trailer—
  - (a) 2 axles with less than 1m between them are taken to be 1 axle; and
  - (b) 3 axles with 2m or less between the first and third axles are taken to be 2 axles; and

[s 222]

---

- (c) 4 axles with 3.2m or less between the first and fourth axles are taken to be 3 axles.
- (4) For subsection (3), the distance between axles is measured between the centres of the wheels—
  - (a) mounted on the axles; and
  - (b) parallel to the length of the vehicle.
- (5) If a category 2 vehicle is registered as a particular type of vehicle stated in schedule 3, a person must not use the vehicle, or, whether or not the person is the vehicle's registered operator, permit another person to use the vehicle, as a vehicle of another type to which a higher registration fee applies.

Maximum penalty—80 penalty units.

*Example—*

If a truck (type 1) or a truck (type 2) is not registered as a short combination truck, a person must not use, or permit another person to use, the vehicle to tow a trailer.

## **Division 2                      Exemptions**

### **222      Eligible person may apply for exemption from paying particular fees**

- (1) A person who is eligible under subsection (2) may apply to the chief executive for an exemption from paying the following fees—
  - (a) a registration fee for a vehicle or dealer plate;
  - (b) a registration administration fee for—
    - (i) conditional registration of a vehicle; or
    - (ii) a category 2 vehicle, other than a trailer;
  - (c) a traffic improvement fee for a category 1 vehicle, other than a trailer.

*Note—*

See part 9, division 2 for requirements for particular applications.

- (2) The person is eligible for the exemption if—
- (a) the person is the registered operator of the vehicle or for the dealer plate or will be its registered operator when it is registered; and
  - (b) for an exemption relating to a vehicle—
    - (i) the person is an association established solely for a charitable purpose and the vehicle is used solely for that purpose; or
    - (ii) the person is a designated person; or
    - (iii) the vehicle is a motorised mobility device used by a person with a disability affecting the person's mobility; and

*Note—*

See also section 223.

- (c) for an exemption relating to a dealer plate—the person is an association established solely for a charitable purpose and the dealer plate is used solely for that purpose.

- (3) In this section—

***charitable purpose*** see the *Collections Act 1966*, section 5.

***designated overseas mission*** means a designated overseas mission under the *Overseas Missions (Privileges and Immunities) Act 1995* (Cwlth).

***designated person*** means a person who is—

- (a) a consulate, the head of a consulate or a career officer of a consulate; or
- (b) the head of an honorary consular mission; or
- (c) a member of staff of a designated overseas mission; or
- (d) the head of a designated overseas mission; or
- (e) an officer of a designated overseas mission.

***officer***, of a designated overseas mission—

[s 223]

---

- (a) means a person entrusted as an officer with the exercise of the functions of the designated overseas mission; but
- (b) does not include a person employed in the technical or administrative service of the designated overseas mission.

**223 Registered operator for motorised mobility device may apply for exemption from paying transfer application fee**

The registered operator of a vehicle mentioned in section 222(2)(b)(iii) may apply to the chief executive for an exemption from paying an application fee for transferring the vehicle's registration.

*Note—*

See part 9, division 2 for requirements for particular applications.

**224 Eligible prescribed service person may apply for exemption from particular fees**

- (1) This section applies to a prescribed person who, under division 3, has been granted an application to pay the concessional registration fee stated in schedule 2, item 15 for—
  - (a) a category 1 vehicle, other than a trailer; or
  - (b) a category 2 vehicle that is a motorised caravan.
- (2) The person may apply to the chief executive for an exemption from paying the following for the vehicle—
  - (a) if the vehicle is a category 1 vehicle, other than a trailer—the traffic improvement fee for the vehicle;
  - (b) if the vehicle is a category 2 vehicle that is a motorised caravan—the registration administration fee for the vehicle.

*Note—*

See part 9, division 2 for requirements for particular applications.

---

## **225 Deciding applications**

- (1) The chief executive must, after considering an application for an exemption made under this division—
  - (a) grant the application; or
  - (b) refuse the application.
- (2) The chief executive may grant the application only if the chief executive is satisfied the applicant is eligible for the exemption.
- (3) Also, the chief executive may only grant an exemption to a person who is eligible under section 222(2)(b)(ii) with the approval of the chief executive of the department administering the *Public Service Act 2008*.
- (4) The chief executive may impose conditions on the grant of an exemption to a person who is eligible under section 222(2)(b)(i).

## **226 Notification requirements for person granted exemption from paying particular fees**

- (1) This section applies to a person who is granted an exemption from paying any of the following fees under section 225—
  - (a) a registration fee for a vehicle or dealer plate;
  - (b) a registration administration fee for—
    - (i) conditional registration of a vehicle; or
    - (ii) a category 2 vehicle, other than a trailer;
  - (c) a traffic improvement fee for a category 1 vehicle, other than a trailer.
- (2) If a circumstance relating to whether the person is eligible for the exemption under section 222(2) or 224 changes, the person must—
  - (a) give the chief executive written notice of the change; and

[s 227]

---

*Note—*

See part 9, division 3 for requirements for particular customer communications.

- (b) ensure the notice is given to the chief executive within 14 days after the change, unless the person has a reasonable excuse.

Maximum penalty—20 penalty units.

- (3) If the exemption is for a registration fee for a vehicle and the person sells or otherwise transfers the vehicle, the person must—
  - (a) give the chief executive written notice of the sale or transfer; and

*Note—*

See part 9, division 3 for requirements for particular customer communications.

- (b) ensure the notice is given to the chief executive within 14 days after the sale or transfer, unless the person has a reasonable excuse.

Maximum penalty—20 penalty units.

## **227 Chief executive must give notice before reassessing fee for which exemption granted**

- (1) This section applies if—
  - (a) an exemption is granted under section 225 for any of the following—
    - (i) a registration fee for a vehicle or dealer plate;
    - (ii) a registration administration fee for—
      - (A) conditional registration of a vehicle; or
      - (B) a category 2 vehicle, other than a trailer;
    - (iii) a traffic improvement fee for a category 1 vehicle, other than a trailer; and

- (b) the chief executive considers the registered operator of the vehicle or for the dealer plate is no longer eligible for the exemption.
- (2) The chief executive may give the registered operator a notice stating—
  - (a) that the chief executive proposes to reassess the registration fee, registration administration fee or traffic improvement fee payable for the vehicle or dealer plate; and
  - (b) the reasons for the proposed reassessment; and
  - (c) that the registered operator may, within a stated period of at least 28 days, give the chief executive a written response to the proposed reassessment.
- (3) The chief executive must consider the registered operator's response before deciding whether to reassess the registration fee, registration administration fee or traffic improvement fee payable for the vehicle or dealer plate.

## **228 Reassessment of fee for which exemption granted**

- (1) This section applies in relation to a vehicle if—
  - (a) the chief executive, after complying with section 227, decides to reassess the registration fee, registration administration fee or traffic improvement fee; or
  - (b) a vehicle's registered operator gives the chief executive a written notice under section 226(3) in relation to the vehicle.
- (2) The chief executive may reassess the registration fee, registration administration fee or traffic improvement fee for the term (the *unexpired term*)—
  - (a) starting on—
    - (i) if subsection (1)(b) applies—the day the vehicle was sold or otherwise transferred; or

[s 228A]

---

- (ii) otherwise—the day the registered operator stopped being eligible for the exemption; and
  - (b) ending on the day the current term of registration of the vehicle or dealer plate expires.
- (3) The chief executive may, by written notice given to the following person, require the person to pay the amount of the reassessed registration fee, registration administration fee or traffic improvement fee for the unexpired term—
  - (a) for a vehicle mentioned in subsection (1)(b)—the person to whom the vehicle was sold or transferred;
  - (b) otherwise—the vehicle’s registered operator.
- (4) The notice must state—
  - (a) the decision to reassess the registration fee, registration administration fee or traffic improvement fee; and
  - (b) the reasons for the decision; and
  - (c) that the decision may be reviewed under section 213.
- (5) The person to whom the notice is given must pay the fee to the chief executive within 28 days after the chief executive gives the notice under subsection (3).

Maximum penalty—60 penalty units.

## **Division 2A                      Recognised primary producers and nominated primary producers**

### **228A    Meaning of *recognised primary producer* and *nominated primary producer***

- (1) A *recognised primary producer* is a person who holds an authorisation under section 228C.
- (2) A *nominated primary producer* for a heavy primary production vehicle is a person given a notice under section 228F(3) authorising the person to use the vehicle.

- 
- (3) However, a person stops being a nominated primary producer for a heavy primary production vehicle—
- (a) if the term of registration of the vehicle ends—3 months after the day the registration ends, unless the registration is renewed; or
  - (b) if the vehicle’s registration is transferred—on the day the transfer is recorded in the register; or
  - (c) on the day there is a change in circumstances relating to whether the person is a primary producer.

### **228B Application to be a recognised primary producer**

A primary producer may apply to the chief executive for an authorisation to be a recognised primary producer.

*Note—*

See part 9, division 2 for requirements for particular applications.

### **228C Deciding application to be a recognised primary producer**

- (1) The chief executive must, after considering an application made under section 228B—
  - (a) grant the application; or
  - (b) refuse the application.
- (2) The chief executive may grant the application only if the chief executive is satisfied the applicant is a primary producer.

### **228D Application to nominate a recognised primary producer**

- (1) A person who is eligible under subsection (2) may apply to the chief executive to nominate a recognised primary producer to use a heavy primary production vehicle.

*Note—*

See part 9, division 2 for requirements for particular applications.

- (2) The person is eligible if—

[s 228E]

---

- (a) the person is the registered operator of the vehicle or will be the registered operator of the vehicle when the vehicle is registered; and
  - (b) the person is, or will be when the vehicle is registered, a recognised primary producer.
- (3) For each vehicle to which the application relates, the person may nominate no more than 5 other persons who are recognised primary producers to use the vehicle.

### **228E Deciding application to nominate a recognised primary producer**

- (1) The chief executive must, after considering an application made under section 228D—
- (a) grant the application; or
  - (b) refuse the application.
- (2) The chief executive may grant the application only if the chief executive is satisfied—
- (a) the applicant is eligible under section 228D(2); and
  - (b) for each heavy primary production vehicle to which the application relates—
    - (i) the vehicle is, or is eligible to be, a concessionally registered vehicle for which the applicant is, or would be, eligible to pay a registration fee under section 233(1); and
    - (ii) each person nominated in section 228D(3) is, or will be when the vehicle is registered, a recognised primary producer.

### **228F Notices and details recorded in the register**

- (1) This section applies if the chief executive decides to grant an application made under section 228D to nominate a recognised primary producer to use a heavy primary production vehicle.

- (2) The chief executive must give the registered operator of the vehicle a notice stating the name and other relevant details of each nominated primary producer for the vehicle.
- (3) Also, the chief executive must give each person nominated in section 228D(3) for the vehicle a notice stating that the nominated primary producer is authorised to use the vehicle.
- (4) The chief executive must record in the register the name and customer reference number of each nominated primary producer for the vehicle.

## **Division 3                    Concessional registration**

### **Subdivision 1            Applying for concessional registration**

#### **229    Eligible person may apply**

- (1) This section applies to a person who is eligible to pay a concessional registration fee under subdivision 2 for a vehicle.
- (2) The person may apply to the chief executive to pay the concessional registration fee stated in schedule 2 or 3 for the vehicle, instead of the registration fee otherwise payable under this regulation, for registering the vehicle in the person's name.

*Note—*

See part 9, division 2 for requirements for particular applications.

#### **230    Deciding application**

- (1) The chief executive may, after considering an application made under section 229—
  - (a) grant the application; or
  - (b) refuse the application.

[s 231]

---

- (2) The chief executive may grant the application only if the chief executive is satisfied the applicant is eligible to pay the concessional registration fee under subdivision 2.
- (3) The chief executive may impose conditions on the grant of an application to pay a concessional registration fee for a special interest vehicle.

### **231 Concessional registration fee for particular vehicles that have, or are proposed to have, 2 registered operators**

- (1) This section applies if—
  - (a) a person (the *applicant*) is eligible to pay a concessional registration fee for a vehicle under section 234, 235 or 236 (each an *eligibility provision*); and
  - (b) the vehicle has, or is proposed in a registration application to have, another registered operator who is eligible to pay a different concessional registration fee for the vehicle under an eligibility provision.
- (2) The concessional registration fee the applicant is eligible to pay for the vehicle under the eligibility provision is taken to be—
  - (a) if the applicant and the other person are spouses of each other—the lowest concessional registration fee either person is eligible to pay under an eligibility provision; or
  - (b) otherwise—the highest concessional registration fee either person is eligible to pay under an eligibility provision.

### **231A Working out amounts of concessional registration fees**

- (1) This section applies for working out the amount of a concessional registration fee expressed in this regulation as a percentage of another fee (a *standard fee*).
- (2) The amount of the concessional registration fee is obtained by—

- (a) multiplying the standard fee by the percentage; and
- (b) rounding the result to the nearest multiple of 5 cents (rounding one-half upwards).

*Example—*

A concessional registration fee is 25% of the standard fee which is expressed as 845.55 fee units. If the value of a fee unit were \$1.015, the amount of the standard fee would be \$858.25, obtained by multiplying 845.55 by \$1.015 and rounding the result under section 220A. The amount of the concessional registration fee would be \$214.55, obtained by multiplying the standard fee of \$858.25 by 25% and rounding the result under subsection (2)(b).

## **Subdivision 2 Eligibility requirements**

### **232 Persons eligible for ambulance vehicles and particular vehicles mentioned in sch 5**

A person is eligible to pay a concessional registration fee for—

- (a) an ambulance vehicle; or
- (b) a motor vehicle mentioned in schedule 5, other than a conditionally registrable vehicle, with a GVM of not more than 4.5t; or
- (c) a category 2 vehicle mentioned in schedule 5, other than a conditionally registrable vehicle.

### **233 Recognised primary producers and primary producers**

- (1) A recognised primary producer is eligible to pay a concessional registration fee for a vehicle, other than a motorbike or conditionally registrable vehicle, mentioned in—
  - (a) schedule 2, part 2, item 11; or
  - (b) schedule 3, part 4, item 29; or
  - (c) schedule 3, part 4, item 30.

[s 234]

---

- (2) A primary producer who is not a recognised primary producer is eligible to pay a concessional registration fee for a vehicle, other than a motorbike or conditionally registrable vehicle, mentioned in—
  - (a) schedule 2, part 2, item 11; or
  - (b) schedule 3, part 4, item 30.
- (3) However, a person mentioned in subsection (1) or (2) is not eligible to pay a concessional registration fee if the person does not own the vehicle.

## **234 Holders of seniors cards**

- (1) A holder of a seniors card is eligible to pay a concessional registration fee for—
  - (a) a motor vehicle, other than a conditionally registrable vehicle or mobile machinery, if the vehicle has a GVM of not more than 4.5t; or
  - (b) a motorised caravan.
- (2) However, the holder is not eligible if—
  - (a) the holder is a registered operator of another concessionally registered vehicle for which the holder paid a concessional registration fee under—
    - (i) this section; or
    - (ii) section 235 or 236; or
  - (b) another person is, or is proposed in a registration application to be, a registered operator of the vehicle, and the other person—
    - (i) is someone other than the holder’s spouse; and
    - (ii) is not eligible to pay a concessional registration fee for the vehicle under this section.
- (3) Also, the holder is not eligible if—
  - (a) the vehicle is to be used mainly by a person other than the holder; or

- 
- (b) the vehicle's purpose of use is recorded in the register as a purpose other than private purposes.
  - (4) In addition, the holder is not eligible if the holder's spouse is—
    - (a) a card holder or prescribed service person; and
    - (b) a registered operator of a concessionally registered vehicle for which the spouse paid a concessional registration fee under—
      - (i) this section; or
      - (ii) section 235 or 236.

### **235 Holders of pensioner concession cards**

- (1) A person who holds a pensioner concession card (a *pensioner*) is eligible to pay a concessional registration fee for—
  - (a) a motor vehicle, other than a conditionally registrable vehicle or mobile machinery, if the vehicle has a GVM of not more than 4.5t; or
  - (b) a motorised caravan.
- (2) However, the pensioner is not eligible if—
  - (a) the pensioner is a registered operator of another concessionally registered vehicle for which the pensioner paid a concessional registration fee under—
    - (i) this section; or
    - (ii) section 234 or 236; or
  - (b) another person is, or is proposed in a registration application to be, a registered operator of the vehicle, and the other person—
    - (i) is someone other than the pensioner's spouse; and
    - (ii) is not eligible to pay a concessional registration fee for the vehicle under this section.
- (3) Also, the pensioner is not eligible if—

[s 235]

---

- (a) the vehicle is to be used mainly by a person other than the pensioner; or
  - (b) the vehicle's purpose of use is recorded in the register as a purpose other than private purposes.
- (4) In addition, the pensioner is not eligible if the pensioner's spouse is—
- (a) a card holder or prescribed service person; and
  - (b) a registered operator of another concessionally registered vehicle for which the spouse paid a concessional registration fee under—
    - (i) this section; or
    - (ii) section 234 or 236.
- (5) Also, the pensioner is not eligible if—
- (a) the pensioner—
    - (i) is receiving a parenting payment that is a pension PP (single) under the *Social Security Act 1991* (Cwlth); and
    - (ii) is not, or is not proposed in a registration application to be, the sole registered operator of the vehicle; or
  - (b) the pensioner—
    - (i) is receiving an income support supplement under the *Veterans' Entitlements Act 1986* (Cwlth); and
    - (ii) has had the pensioner's rate of income support supplement reduced by—
      - (A) the ordinary/adjusted income test under schedule 6, part 2, module E of that Act; or
      - (B) the assets test under schedule 6, part 2, module F of that Act.

---

## **236 Prescribed service persons**

- (1) A prescribed service person is eligible to pay a concessional registration fee for—
  - (a) a motor vehicle, other than a conditionally registrable vehicle or mobile machinery, if the vehicle has a GVM of not more than 4.5t; or
  - (b) a motorised caravan.
- (2) However, the prescribed service person is not eligible if—
  - (a) the prescribed service person is a registered operator of another concessionally registered vehicle for which the person paid a concessional registration fee under—
    - (i) this section; or
    - (ii) section 234 or 235; or
  - (b) another person is, or is proposed in a registration application to be, a registered operator of the vehicle, and the other person—
    - (i) is someone other than the prescribed service person's spouse; and
    - (ii) is not eligible to pay a concessional registration fee for the vehicle under this section.
- (3) Also, the prescribed service person is not eligible if—
  - (a) the vehicle is to be used mainly by a person other than the prescribed service person; or
  - (b) the vehicle's purpose of use is recorded in the register as a purpose other than private purposes.
- (4) In addition, the prescribed service person is not eligible if the person's spouse is—
  - (a) a card holder or prescribed service person; and
  - (b) a registered operator of another concessionally registered vehicle for which the spouse paid a concessional registration fee under—
    - (i) this section; or

[s 237]

---

(ii) section 234 or 235.

### **237 Special interest vehicles**

A person is eligible to pay a concessional registration fee for a special interest vehicle.

### **238 When registered operator for concessionally registered vehicle stops being eligible for concessional registration**

The registered operator of a concessionally registered vehicle stops being eligible for the concessional registration of the vehicle if the person—

- (a) stops being eligible for the concessional registration under this subdivision; or
- (b) contravenes a provision of subdivision 3 in relation to the vehicle.

## **Subdivision 3 Use of concessionally registered vehicles**

### **239 Use of concessionally registered vehicles generally**

- (1) This section applies to a registered operator of a concessionally registered vehicle.
- (2) The registered operator must not use the vehicle, or permit the vehicle to be used, in a way that would make the registered operator ineligible for the concessional registration of the vehicle.

Maximum penalty—

- (a) if the concessionally registered vehicle is a category 1 vehicle or a motorised caravan—20 penalty units; or
- (b) otherwise—60 penalty units.

---

## 240 Use of farm plate vehicle

- (1) The registered operator of a farm plate vehicle—
  - (a) must not use the vehicle, or permit the vehicle to be used, other than solely for the purposes of—
    - (i) carrying on the registered operator’s primary production business; and
    - (ii) travelling within or between parcels of land that are managed by the registered operator as part of the registered operator’s primary production business; and
  - (b) must not, in a single continuous trip, use the vehicle, or permit the vehicle to be used, to travel—
    - (i) more than 20km per trip within heavy vehicle zone 1; or
    - (ii) more than 40km per trip within heavy vehicle zone 2; or
    - (iii) more than 80km per trip within heavy vehicle zone 3.

### Maximum penalty—

- (a) if the farm plate vehicle is a category 1 vehicle—20 penalty units; or
  - (b) if the farm plate vehicle is a category 2 vehicle—60 penalty units.
- (2) However, if the vehicle is used to travel within 2 or more heavy vehicle zones mentioned in subsection (1)(b), the registered operator does not contravene that subsection if, during the single continuous trip—
    - (a) the vehicle does not travel a distance more than the distance permitted under subsection (1)(b) for each heavy vehicle zone through which the vehicle travels; and
    - (b) the total distance travelled is not more than the higher, or highest, of the distances permitted under

[s 241]

---

subsection (1)(b) for the heavy vehicle zones through which the vehicle travels.

(3) In this section—

**heavy vehicle zone** means a heavy vehicle zone identified in the document called ‘Heavy vehicle zone maps: Queensland’ published by the department and available on the department’s website.

**single continuous trip** means a period of continuous driving, excluding any interruption that is reasonably necessary for, connected with or incidental to the driving.

*Examples of an interruption that is reasonably necessary for, connected with or incidental to a period of continuous driving—*

- stopping the motor vehicle being driven to rest
- refuelling the motor vehicle being driven
- assisting a person with a broken-down motor vehicle

## 241 Use of restricted primary production vehicles

(1) The registered operator of a restricted primary production vehicle, or a nominated primary producer for the vehicle, must not use the vehicle, or permit the vehicle to be used, other than—

- (a) for carrying on the primary production business of the registered operator or nominated primary producer; or
- (b) for a purpose permitted under section 191.

Maximum penalty—80 penalty units.

(2) In this section—

**restricted primary production vehicle** means a concessionally registered vehicle, other than a category 2 vehicle mentioned in schedule 5, for which a registration fee was paid under schedule 3, part 4, item 29.

---

**242 Use of concessionally registered special interest vehicle for which condition imposed**

The registered operator of a concessionally registered special interest vehicle for which the chief executive has imposed a condition under section 230(3) must not use the vehicle, or permit the vehicle to be used, in contravention of the condition.

Maximum penalty—

- (a) if the concessionally registered special interest vehicle is a category 1 vehicle—20 penalty units; or
- (b) if the concessionally registered special interest vehicle is a category 2 vehicle—60 penalty units.

**Subdivision 4 Notification requirements for, and reassessment of, concessional registration**

**243 Notification requirements for registered operators of concessionally registered vehicles**

- (1) This section applies to the registered operator of a concessionally registered vehicle, other than a relevant vehicle under section 243A.
- (2) If a circumstance relating to whether the registered operator is eligible for the concessional registration of the vehicle changes, the registered operator must—
  - (a) give the chief executive notice of the change in circumstance; and

*Note—*

See part 9, division 3 for requirements for particular customer communications.

- (b) ensure the notice is given to the chief executive within 14 days after the change, unless the registered operator has a reasonable excuse.

[s 243A]

---

Maximum penalty—

- (a) if the concessionally registered vehicle is a category 1 vehicle or a motorised caravan—20 penalty units; or
  - (b) otherwise—60 penalty units.
- (3) If the registered operator sells or otherwise transfers the vehicle, the registered operator must—
- (a) give the chief executive written notice of the sale or transfer; and

*Note—*

See part 9, division 3 for requirements for particular customer communications.

- (b) ensure the notice is given to the chief executive within 14 days after the sale or transfer, unless the registered operator has a reasonable excuse.

Maximum penalty—

- (a) if the concessionally registered vehicle is a category 1 vehicle or a motorised caravan—20 penalty units; or
- (b) otherwise—60 penalty units.

### **243A Notification requirements for registered operators of relevant vehicles and nominated primary producers**

- (1) This section applies if—
  - (a) a person is, for a relevant vehicle—
    - (i) the registered operator of the vehicle; or
    - (ii) a nominated primary producer for the vehicle; and
  - (b) there is a change in circumstances relating to whether the person is a primary producer.
- (2) The person must—
  - (a) give the chief executive notice of the change in circumstances; and

*Note—*

See part 9, division 3 for requirements for particular customer communications.

- (b) ensure the notice is given to the chief executive within 14 days after the change, unless the person has a reasonable excuse.

Maximum penalty—80 penalty units.

- (3) In this section—

***relevant vehicle*** means a concessionally registered vehicle for which a registration fee was paid under—

- (a) schedule 2, part 2, item 11; or
- (b) schedule 3, part 4, item 29; or
- (c) schedule 3, part 4, item 30.

## **244 Chief executive must give notice before reassessing registration fee**

- (1) This section applies in relation to a concessionally registered vehicle if the chief executive considers the registered operator has stopped being eligible for the concessional registration of the vehicle under section 238.
- (2) The chief executive may give the registered operator a notice stating—
  - (a) that the chief executive proposes to reassess, under section 245, the registration fee payable for the vehicle's registration; and
  - (b) the reasons for the proposed reassessment; and
  - (c) that the registered operator may, within a stated period of at least 28 days, give the chief executive a written response to the proposed reassessment.
- (3) The chief executive must consider the registered operator's response before deciding whether to reassess the registration fee payable for the vehicle.

[s 245]

---

## **245 Reassessment of registration fee**

- (1) This section applies in relation to a concessionally registered vehicle if—
  - (a) the chief executive, after complying with section 244, decides to reassess the registration payable for the vehicle; or
  - (b) the vehicle’s registered owner gives the chief executive a written notice under section 243(2) or (3).
- (2) The chief executive must reassess the registration fee for the period (the *unexpired term*)—
  - (a) starting on—
    - (i) if subsection (1)(a) applies—the day the person stopped being eligible for the concessional registration; or
    - (ii) if subsection (1)(b) applies—the day the chief executive received the notice; and
  - (b) ending on the day the vehicle’s current term of registration expires.
- (3) From the start of the period mentioned in subsection (2), the vehicle—
  - (a) is no longer concessionally registered; but
  - (b) is taken to be a registered vehicle until the vehicle’s current term of registration expires.

## **246 Notice of decision**

- (1) The chief executive must give the registered operator of the concessionally registered vehicle a notice of the decision to reassess, and the reassessment, made under section 245.
- (2) The notice must state—
  - (a) the decision to reassess; and
  - (b) the reasons for the decision; and

- 
- (c) the amount of the difference (the *fee balance*) between the concessional registration fee and the registration fee, as reassessed for the unexpired term under section 245; and
  - (d) if the registered operator is required to pay the fee balance—the requirement; and
  - (e) that the decision, including the requirement to pay the fee balance, may be reviewed under section 213.
- (3) If the notice requires the person to pay the fee balance, the person must comply with the requirement within 28 days after the notice is given.

Maximum penalty—

- (a) if the vehicle is a category 1 vehicle or a motorised caravan—20 penalty units; or
- (b) otherwise—60 penalty units.

## Part 15 Transitional provisions

### Division 1 Transitional provisions for SL No. 113 of 2021

#### 247 Definition for part

In this part—

*expired regulation* means the expired *Transport Operations (Road Use Management—Vehicle Registration) Regulation 2010*.

#### 248 Applications made before commencement

- (1) This section applies if—
  - (a) before the commencement, an application was made for—

[s 248]

---

- (i) registration, or renewal of registration, of a vehicle under the expired regulation, part 3, division 3; or
  - (ii) registration, or renewal of registration, of a dealer plate under the expired regulation, part 7, division 2; or
  - (iii) an authorisation to use an unregistered vehicle, or class of unregistered vehicle, on a road under the expired regulation, section 107; or
  - (iv) cancellation of a vehicle's registration under the expired regulation, part 6; or
  - (v) an unregistered vehicle permit under the expired regulation, part 7, division 1; or
  - (vi) an approval to perform, or supervise day-to-day running of, written-off vehicle inspections under the expired regulation, section 84; or
  - (vii) an approval of a production motorbike as a learner approved motorbike under the expired regulation, part 3, division 4; or
  - (viii) an exemption from paying a fee under the expired regulation, section 122; or
  - (ix) a concessional registration fee under the expired regulation, part 11, division 3 or 4; and
- (b) on the commencement, the application has not been decided.
- (2) The application must be decided under the expired regulation as if that regulation had not expired.
- (3) A decision on an application mentioned in subsection (1) is taken to be a decision made under—
- (a) for registration, or renewal of registration, of a vehicle—section 21 or 34;
  - (b) for registration, or renewal of registration, of a dealer plate—section 79 or 87;

- (c) for an authorisation to use an unregistered vehicle on a road—section 14;
- (d) for cancellation of a vehicle’s registration—section 61;
- (e) for an unregistered vehicle permit—section 74;
- (f) for an approval to perform, or supervise day-to-day running of, written-off vehicle inspections—section 166;
- (g) for an approval of a production motorbike as a learner approved motorbike—section 217;
- (h) for an exemption from paying a fee—section 225;
- (i) for a concessional registration fee—section 230.

## **249 References to recorded expiry day**

A reference to the recorded expiry day for a vehicle or dealer plate includes a reference to—

- (a) for registration of a vehicle that expired before the commencement—the day the vehicle’s registration expired under the expired regulation, section 52; or
- (b) for registration of a dealer plate that expired before the commencement—the day the dealer plate’s registration was recorded on the register as expiring under the expired regulation, section 62(5)(b)(iii).

## **250 Continuation of expired regulation, pt 9, div 1 and existing natural disaster relief notices**

- (1) This section applies if a natural disaster relief notice, published under the expired regulation, section 96(2), was in effect immediately before the commencement.
- (2) On the commencement—
  - (a) the natural disaster relief notice continues in effect; and
  - (b) the expired regulation, part 9, division 1 continues to apply in relation to the vehicle for the period the natural

[s 251]

---

disaster relief notice has effect, as if that regulation had not expired.

**251 Continuation of expired regulation, pt 9, div 2 and existing drought declarations**

- (1) This section applies if, immediately before the commencement, a drought declaration was in force under the expired regulation, part 9, division 2.
- (2) On the commencement, the expired regulation, part 9, division 2 continues to apply in relation to an eligible vehicle as if that regulation had not expired.
- (3) In this section—  
*eligible vehicle* see the expired regulation, section 100A.

**252 Existing entitlements to review**

- (1) This section applies in relation to a decision mentioned in the expired regulation, section 110 made before the commencement.
- (2) The expired regulation, part 10, division 4 continues to apply in relation to the decision as if that regulation had not expired.

**253 References to inspection approvals**

An approval granted under the expired regulation, part 8, division 3 is taken, from the commencement, to be an inspection approval under this regulation.

**254 Continuation of register**

The register kept under the expired regulation, section 18 is continued as the register required to be kept under part 5.

## 255 References to expired regulation

In an Act or other document, a reference to the *Transport Operations (Road Use Management—Vehicle Registration) Regulation 2010* may, if the context permits, be taken to be a reference to this regulation.

## 256 Acts Interpretation Act 1954 not limited

This part does not limit the *Acts Interpretation Act 1954*, section 20.

## Division 2 Transitional provision for Transport Legislation (Fee Unit Conversion and Registration Fees) Amendment Regulation 2022

### 257 Fees payable under relevant provisions for registration

- (1) This section applies in relation to a fee payable under a relevant provision, if the fee—
  - (a) relates to the registration of a vehicle or a dealer plate for a term that starts, or for section 220(5) is taken to start, on or after the commencement but before 1 July 2022; and
  - (b) is expressed as a number of fee units.
- (2) Despite section 220(5)(a), the fee payable under the relevant provision is the fee in force on the commencement.
- (3) In this section—

*relevant provision* means schedule 2 or 3 or schedule 4, part 3 or 4.

[s 258]

---

### **Division 3**

## **Transitional provision for Transport Operations (Road Use Management—Vehicle Registration) and Other Legislation Amendment Regulation 2023**

#### **258 Existing registered operators of heavy primary production vehicles**

- (1) This section applies if, immediately before the commencement, a person was the registered operator of a heavy primary production vehicle for which a concessional registration fee was paid under former section 233(3)(a).
- (2) The person is taken to be a recognised primary producer if—
  - (a) the person—
    - (i) applies under section 228D to nominate another person as a nominated primary producer authorised to use the vehicle; or
    - (ii) applies for registration of another heavy primary production vehicle and the other vehicle is to be concessionally registered; and
  - (b) the application is granted.
- (3) In this section—

*former*, for a provision of this regulation, means the provision as in force from time to time before the commencement.

---

## Schedule 1 Exempt vehicles

### section 4

- 1 An agricultural implement, if—
  - (a) the agricultural implement is being towed; and
  - (b) the vehicle towing the implement—
    - (i) is an agricultural machine or another vehicle; and
    - (ii) is suitably matched, or of a suitable size, for towing the implement
- 2 Drawn plant, if the plant is being towed by a conditionally registered vehicle of a size suitable for towing the plant
- 3 A motorbike, if the motorbike is being used in—
  - (a) a freestyle motocross area; or
  - (b) an observed trial area
- 4 A motorised golf buggy, if the buggy is being used—
  - (a) on a golf course or in a golf course car park; or
  - (b) for crossing a road dividing a golf course using the shortest possible route
- 5 Motorised machinery for use on a golf course, other than a motorised golf buggy, if the machinery is being used—
  - (a) on a golf course; or
  - (b) in a golf course carpark

*Examples of motorised machinery for use on a golf course—*  
motorised precision sprayer, motorised aerator
- 6 A motorised mobility device, if the device is being used by a person who—
  - (a) does not usually reside in Queensland; or
  - (b) has resided in Queensland for 14 days or less
- 7 A motor vehicle that—

Schedule 1

---

- (a) does not have an internal combustion engine; and
  - (b) is propelled by—
    - (i) a motor with a maximum power output of not more than 200W; or
    - (ii) 2 or more motors with a combined maximum power output of not more than 200W
- 8 A racing vehicle, if the vehicle is being used—
- (a) on a racing track; or
  - (b) in a track-related area
- 9 A ride-on mower, if the mower—
- (a) is not an agricultural machine; and
  - (b) is being used for mowing; and
  - (c) is—
    - (i) crossing a road using the shortest possible route; or
    - (ii) on a road-related area
- 10 A trailer, if the trailer is being towed by—
- (a) an agricultural machine being used for its ordinary agricultural purpose; or
  - (b) a conditionally registered vehicle with limited access registration
- 11 An unregistered vehicle, if the vehicle is dealer’s stock being used on the dealer’s premises
- 12 A vehicle being towed by a tow truck
- 13 A vehicle that is not a motor vehicle, trailer or motorised mobility device
- 14 Walking speed equipment, if the equipment is on a road only for—
- (a) loading the equipment onto, or unloading the equipment from, another vehicle; or
  - (b) repositioning the equipment at a work site

## Schedule 2      Category 1 vehicle registration fees for 1 year

sections 220(1) and 229(2)

### Part 1      Registration fees

		Fee if vehicle is prescribed private use vehicle	Fee if vehicle is not prescribed private use vehicle
		Fee units	Fee units
1	Motor vehicle, other than a motorbike, with a GVM of not more than 4t—		
	(a) 1, 2 or 3 cylinders, electric or steam	267.50	290.25
	(b) 4 cylinders or 2 rotors	340.20	369.20
	(c) 5 or 6 cylinders or 3 rotors	538.65	584.45
	(d) 7 or 8 cylinders	754.35	818.55
	(e) 9 to 12 cylinders	884.70	959.90
2	Motor vehicle, other than a motorised caravan or bus, with a GVM of more than 4t but not more than 4.5t	845.55	917.60
3	Motorised caravan with a GVM of more than 4t but not more than 4.5t	614.60	666.95
4	Bus with a GVM of more than 4t but not more than 4.5t	842.75	914.45
5	Mobile machinery—		
	(a) GVM of not more than 1t		208.15

Schedule 2

---

	<b>Fee if vehicle is prescribed private use vehicle</b>	<b>Fee if vehicle is not prescribed private use vehicle</b>
	<b>Fee units</b>	<b>Fee units</b>
(b) GVM of more than 1t but not more than 2t		285.25
(c) GVM of more than 2t but not more than 3t		362.60
(d) GVM of more than 3t but not more than 4t		439.75
(e) GVM of more than 4t but not more than 4.5t		445.85
6 Motorbike		128.50
7 Trailer—		
(a) if the trailer is a small trailer		116.35
(b) otherwise		221.55

*Note—*

Under schedule 8, definition *caravan*, a caravan is a type of trailer.

## Part 2 Concessional registration fees

	<b>Fee if vehicle is prescribed private use vehicle</b>	<b>Fee if vehicle is not prescribed private use vehicle</b>
	<b>Fee units</b>	<b>Fee units</b>
8 Ambulance vehicle		104.05
9 Motor vehicle mentioned in schedule 5, other than a conditionally registrable vehicle, with a GVM of not more than 4t	95.85	104.05
10 Motor vehicle mentioned in schedule 5, other than a conditionally registrable vehicle, with a GVM of more than 4t but not more than 4.5t, the greater of the following—		
(a) 25% of the fee stated in part 1 for the vehicle		
(b)	95.85	104.05
11 Vehicle, other than a motorbike or conditionally registrable vehicle, owned by a primary producer and used in the producer's business as a primary producer—		
(a) motor vehicle with a GVM of not more than 4t		109.90
(b) motor vehicle with a GVM of more than 4t but not more than 4.5t		160.70
(c) trailer with an ATM of not more than 4.5t		109.90

Schedule 2

---

	<b>Fee if vehicle is prescribed private use vehicle</b>	<b>Fee if vehicle is not prescribed private use vehicle</b>
	<b>Fee units</b>	<b>Fee units</b>
12 Motor vehicle, other than a conditionally registrable vehicle or mobile machinery, for a holder of a seniors card, if the vehicle has a GVM of not more than 4.5t—the greater of the following—		
(a) 50% of the fee stated in part 1 for the vehicle		
(b)	95.85	104.05
13 Motor vehicle, other than a conditionally registrable vehicle or mobile machinery, for a pre-1994 pensioner—		
(a) if the vehicle has a GVM of not more than 4t	95.85	104.05
(b) if the vehicle has a GVM of more than 4t but not more than 4.5t, the greater of the following—		
(i) 25% of the fee stated in part 1 for the vehicle		
(ii)	95.85	104.05
14 Motor vehicle, other than a conditionally registrable vehicle or mobile machinery, for a holder of a pensioner concession card who is not a pre-1994 pensioner, if the vehicle has a GVM of not more than 4.5t—the greater of the following—		
(a) 50% of the fee stated in part 1 for the vehicle		

	<b>Fee if vehicle is prescribed private use vehicle</b>	<b>Fee if vehicle is not prescribed private use vehicle</b>
	<b>Fee units</b>	<b>Fee units</b>
(b)	95.85	104.05
15 Motor vehicle, other than a conditionally registrable vehicle or mobile machinery, for a prescribed service person if the vehicle has a GVM of not more than 4.5t	95.85	104.05
16 Special interest vehicle—		
(a) for a motorbike		36.20
(b) for a special interest vehicle other than a motorbike	95.85	104.05

## Schedule 3 Category 2 vehicle registration fees for 1 year

sections 220(2) and (3) and 229(2)

### Part 1 Registration fees for financial year starting on 1 July 2024—nationally regulated fees

#### Truck and prime mover charging category

Truck or prime mover type	2 axles	3 axles	4 axles	5 or more axles
	\$	\$	\$	\$
1 Trucks—				
(a) truck (type 1)—				
(i) road use component	485.00	876.00	876.00	876.00
(ii) regulatory component	199.00	235.00	250.00	250.00
(b) truck (type 2)—				
(i) road use component	876.00	994.00	994.00	994.00
(ii) regulatory component	260.00	332.00	353.00	353.00
(c) short combination truck—				
(i) road use component	876.00	994.00	1,993.00	1,993.00
(ii) regulatory component	291.00	370.00	354.00	354.00
(d) medium combination truck—				

**Truck and prime mover charging category**

Truck or prime mover type	2 axles	3 axles	4 axles	5 or more axles
	\$	\$	\$	\$
(i) road use component	10,839.00	10,839.00	11,707.00	11,707.00
(ii) regulatory component	663.00	663.00	717.00	717.00
(e) long combination truck—				
(i) road use component	14,985.00	14,985.00	14,985.00	14,985.00
(ii) regulatory component	916.00	916.00	916.00	916.00
2 Prime movers—				
(a) short combination prime mover—				
(i) road use component	847.00	4,831.00	5,193.00	5,193.00
(ii) regulatory component	413.00	413.00	413.00	413.00
(b) multi-combination prime mover—				
(i) road use component	12,255.00	12,255.00	13,481.00	13,481.00
(ii) regulatory component	933.00	933.00	1,025.00	1,025.00

**Trailer charging category**

Trailer type	single axle or single axle group	tandem axle group	tri-axle group	quad-axle group	multi-axle group, for each axle
	\$	\$	\$	\$	\$
3 Pig trailer—					

## Schedule 3

**Trailer charging category**

Trailer type	single axle or single axle group	tandem axle group	tri-axle group	quad-axle group	multi- axle group, for each axle
	\$	\$	\$	\$	\$
(a) road use component	720.00	1,440.00	2,160.00	2,880.00	720.00
(b) regulatory component	55.00	56.00	54.00	56.00	14.00
4 Dog trailer—					
(a) road use component	720.00	1,440.00	2,160.00	2,880.00	720.00
(b) regulatory component	55.00	56.00	54.00	56.00	14.00
5 Semitrailer—					
(a) road use component	720.00	1,830.00	1,950.00	1,952.00	488.00
(b) regulatory component	55.00	56.00	54.00	56.00	14.00
6 B-double lead trailer, B-triple lead trailer or B-triple middle trailer—					
(a) road use component	720.00	1,830.00	1,950.00	1,952.00	488.00
(b) regulatory component	55.00	56.00	54.00	56.00	14.00
7 Converter dolly or low loader dolly—					
(a) road use component	nil	nil	nil	nil	nil
(b) regulatory component	55.00	56.00	54.00	56.00	14.00

**Bus charging category**

<b>Bus type</b>		<b>2 axles</b>	<b>3 axles</b>	<b>4 or more axles</b>
		<b>\$</b>	<b>\$</b>	<b>\$</b>
8	Bus (type 1)—			
	(a) road use component	363.00	nil	nil
	(b) regulatory component	208.00	nil	nil
9	Bus (type 2)—			
	(a) road use component	376.00	2,751.00	2,751.00
	(b) regulatory component	341.00	423.00	423.00
10	Articulated bus—			
	(a) road use component	nil	376.00	376.00
	(b) regulatory component	nil	338.00	338.00

**Special purpose vehicle charging category**

				<b>\$</b>
11	Special purpose vehicle (type o)—			
	(a) road use component	441.00 + 441.00 for each axle in excess of 2 axles		
	(b) regulatory component			206.00
12	Special purpose vehicle (type p)—			
	(a) road use component			nil
	(b) regulatory component			nil
13	Special purpose vehicle (type t)—			
	(a) road use component			353.00
	(b) regulatory component			206.00

## Part 2 Registration fees for financial year starting on 1 July 2025—nationally regulated fees

### Truck and prime mover charging category

Truck or prime mover type	2 axles	3 axles	4 axles	5 or more axles
	\$	\$	\$	\$
14 Trucks—				
(a) truck (type 1)—				
(i) road use component	512.00	942.00	942.00	942.00
(ii) regulatory component	202.00	239.00	254.00	254.00
(b) truck (type 2)—				
(i) road use component	942.00	1,069.00	1,069.00	1,069.00
(ii) regulatory component	264.00	337.00	358.00	358.00
(c) short combination truck—				
(i) road use component	942.00	1,069.00	2,106.00	2,106.00
(ii) regulatory component	295.00	376.00	359.00	359.00
(d) medium combination truck—				
(i) road use component	11,652.00	11,652.00	12,585.00	12,585.00
(ii) regulatory component	673.00	673.00	728.00	728.00
(e) long combination truck—				

**Truck and prime mover charging category**

Truck or prime mover type	2 axles	3 axles	4 axles	5 or more axles	
	\$	\$	\$	\$	\$
(i) road use component	16,109.00	16,109.00	16,109.00	16,109.00	16,109.00
(ii) regulatory component	930.00	930.00	930.00	930.00	930.00
15 Prime movers—					
(a) short combination prime mover—					
(i) road use component	895.00	5,105.00	5,488.00	5,488.00	5,488.00
(ii) regulatory component	419.00	419.00	419.00	419.00	419.00
(b) multi-combination prime mover—					
(i) road use component	12,950.00	12,950.00	14,245.00	14,245.00	14,245.00
(ii) regulatory component	947.00	947.00	1,040.00	1,040.00	1,040.00

**Trailer charging category**

Trailer type	single axle or single axle group	tandem axle group	tri-axle group	quad-axle group	multi-axle group, for each axle
	\$	\$	\$	\$	\$
16 Pig trailer—					
(a) road use component	761.00	1,522.00	2,283.00	3,044.00	761.00
(b) regulatory component	55.00	56.00	54.00	56.00	14.00
17 Dog trailer—					

Schedule 3

**Trailer charging category**

Trailer type	single axle or single axle group	tandem axle group	tri-axle group	quad-axle group	multi-axle group, for each axle
	\$	\$	\$	\$	\$
(a) road use component	761.00	1,522.00	2,283.00	3,044.00	761.00
(b) regulatory component	55.00	56.00	54.00	56.00	14.00
18 Semitrailer—					
(a) road use component	761.00	1,934.00	2,061.00	2,064.00	516.00
(b) regulatory component	55.00	56.00	54.00	56.00	14.00
19 B-double lead trailer, B-triple lead trailer or B-triple middle trailer—					
(a) road use component	761.00	1,934.00	2,061.00	2,064.00	516.00
(b) regulatory component	55.00	56.00	54.00	56.00	14.00
20 Converter dolly or low loader dolly—					
(a) road use component	nil	nil	nil	nil	nil
(b) regulatory component	55.00	56.00	54.00	56.00	14.00

**Bus charging category**

Bus type	2 axles	3 axles	4 or more axles
	\$	\$	\$
21 Bus (type 1)—			
(a) road use component	384.00	nil	nil
(b) regulatory component	211.00	nil	nil

**Bus charging category**

<b>Bus type</b>	<b>2 axles</b>	<b>3 axles</b>	<b>4 or more axles</b>
	\$	\$	\$
22 Bus (type 2)—			
(a) road use component	404.00	2,957.00	2,957.00
(b) regulatory component	346.00	429.00	429.00
23 Articulated bus—			
(a) road use component	nil	404.00	404.00
(b) regulatory component	nil	343.00	343.00

**Special purpose vehicle charging category**

		\$
24 Special purpose vehicle (type o)—		
(a) road use component	466.00 + 466.00 for each axle in excess of 2 axles	
(b) regulatory component		209.00
25 Special purpose vehicle (type p)—		
(a) road use component		nil
(b) regulatory component		nil
26 Special purpose vehicle (type t)—		
(a) road use component		373.00
(b) regulatory component		209.00

## Part 3 Registration fees—non-nationally regulated fees

Vehicle type	2 axles	3 axles	4 axles	5 or more axles
	Fee units	Fee units	Fee units	Fee units
27 Motorised caravan	647.40	1,294.90	1,942.15	1,942.15

## Part 4 Concessional registration fees

- 28 Ambulance vehicle—104.05 fee units.
- 29 Heavy primary production vehicle, or category 2 vehicle mentioned in schedule 5, other than a conditionally registrable vehicle—the following percentage of the registration fee stated in part 1 or 2 for the vehicle—
- for a truck with 2 or 3 axles—50%;
  - for a truck with 4 or more axles—25%;
  - for a short combination prime mover, or a short combination truck, medium combination truck or long combination truck, with 2 axles—50%;
  - for a multi-combination prime mover with 2 axles—25%;
  - for a short combination prime mover or multi-combination prime mover, or a short combination truck, medium combination truck or long combination truck, with 3 or more axles—25%;
  - for a trailer with 1 axle—50%;
  - for a trailer with 2 axles—35%;
  - for a trailer with 3 or more axles—30%;

- 
- (i) for a special purpose vehicle—25%;
  - (j) for a caravan, mobile library, mobile workshop, mobile laboratory or mobile billboard—35%;
  - (k) for a bus—50%.
- 30 Vehicle, other than a conditionally registrable vehicle, owned by a primary producer and used in the producer’s business as a primary producer—
- (a) for a motor vehicle—67.35 fee units
  - (b) for a trailer—160.70 fee units.
- 31 Motorised caravan—the following percentage of the registration fee stated in item 27 for the vehicle—
- (a) for a holder of a seniors card—50%;
  - (b) for a holder of a pensioner concession card—
    - (i) if the holder is a pre-1994 pensioner—25%; or
    - (ii) otherwise—50%;
  - (c) for a prescribed service person—25%.
- 32 Special interest vehicle—104.05 fee units.

## Schedule 4 Other fees

section 220(4)

### Part 1 Nationally regulated plate fees

	\$
1 Plate fee for national heavy vehicle number plates (s 20(2)(b)(i))	31.10
2 Application fee for replacement of the following (s 123(3)(a)(i))—	
(a) an accessory plate for a category 2 vehicle with national heavy vehicle number plates	31.10 plus manufacturing costs
(b) a national heavy vehicle number plate, or a pair of national heavy vehicle number plates, with the same combination of numbers or letters and design as the replaced plate or plates	31.10 plus manufacturing costs
(c) a national heavy vehicle number plate, or a pair of national heavy vehicle number plates, with a new combination of numbers or letters	31.10
3 Application fee for replacement national heavy vehicle number plates (s 131(3)(a))	31.10
4 Application fee for accessory plate, for category 2 vehicle with national heavy vehicle number plates (ss 139(2)(b) and 141(2))	31.10

## Part 2 Other plate fees

	<b>Fee units</b>
5 Plate fee for limousine number plates (s 20(2)(b)(i))	48.15
6 Plate fee for fire and emergency appliance number plates (s 20(2)(b)(i))	54.25
7 Plate fee for other number plates (s 20(2)(b)(i))	32.00
8 Application fee for replacement of any of the following, unless item 9 applies (s 123(3)(a)(i))—	
(a) dealer plate	118.75
(b) pair of limousine number plates	48.15
(c) another pair of number plates	32.00
9 Application fee for replacement number plate, or pair of number plates, with the same combination of numbers or letters and design as the replaced plate or plates (s 123(3)(a)(i))	32.00 plus manufacturing costs
10 Application fee for accessory plate (ss 139(2)(b) and 141(2))	32.00

## Part 3 Fees relating to vehicle registration

	<b>Fee units</b>
11 Surcharge for processing a registration application, or renewal application, for a term of more than 6 months but less than 1 year (ss 20(2)(b)(ii) and 37(4))—	
(a) for a category 1 vehicle (other than concessional registration or conditional registration)	8.95
(b) for a category 2 vehicle (other than conditional registration)	39.85

Schedule 4

	<b>Fee units</b>
(c) for concessional registration of a category 1 vehicle	5.45
(d) for conditional registration of a vehicle	8.95
12 Surcharge for processing a registration application, or renewal application, for a term of more than 3 months but not more than 6 months (ss 20(2)(b)(ii) and 37(4))—	
(a) for a category 1 vehicle (other than concessional registration or conditional registration)	8.95
(b) for a category 2 vehicle (other than conditional registration)	39.85
(c) for concessional registration of a category 1 vehicle	5.45
(d) for conditional registration of a vehicle	8.95
13 Surcharge for processing a registration application, or renewal application, for a term of more than 1 month but not more than 3 months (ss 20(2)(b)(ii) and 37(4))—	
(a) for a category 1 vehicle (other than concessional registration or conditional registration)	4.45
(b) for a category 2 vehicle (other than conditional registration)	19.95
(c) for concessional registration of a category 1 vehicle	2.70
(d) for conditional registration of a vehicle	4.45
14 Surcharge for processing a registration application, or renewal application, for a term of up to 1 month (ss 20(2)(b)(ii) and 37(4))—	
(a) for a category 1 vehicle (other than concessional registration or conditional registration)	1.55
(b) for a category 2 vehicle (other than conditional registration)	6.60

	<b>Fee units</b>
(c) for concessional registration of a category 1 vehicle	1.00
(d) for conditional registration of a vehicle	1.55
15 Registration administration fee for conditional registration (ss 20(2)(b)(iii) and 33(1)(b)(i))—	
(a) limited access registration	50.80
(b) zone access registration	50.80
(c) unrestricted access registration	111.20
16 Registration administration fee for a category 2 vehicle other than a trailer (ss 20(2)(b)(iv) and 33(1)(b)(ii))	77.90
17 Traffic improvement fee for a category 1 vehicle other than a trailer (ss 20(2)(b)(v) and 33(1)(b)(iii))—	
(a) if the vehicle is a prescribed private use vehicle	59.35
(b) otherwise	64.45
18 Administrative fee for renewal of a vehicle's registration, after the recorded expiry day for the registration, for a term other than 1 month (ss 33(1)(b)(iv) and 39(2))—	
(a) if the renewal of registration is for a category 1 vehicle or a category 2 vehicle other than—	
• a trailer that is a category 1 vehicle	
• a special interest vehicle for which a concessional registration fee has been granted under part 14, division 3	
• a conditionally registered vehicle	
• a vehicle for which an exemption from the payment of the registration fee payable for the renewal, applied for under section 222(2)(a) and (b)(i) or (ii), has been granted under section 225	
• drawn plant	67.65

Schedule 4

	<b>Fee units</b>
(b) otherwise	16.80
19 Administrative fee for renewal of a vehicle's registration, after the recorded expiry day for the registration, for a term of 1 month (ss 33(1)(b)(iv) and 39(2))—	
(a) if the renewal of registration is for a category 1 vehicle or a category 2 vehicle other than—	
• a trailer that is a category 1 vehicle	
• a special interest vehicle for which a concessional registration fee has been granted under part 14, division 3	
• a conditionally registered vehicle	
• a vehicle for which an exemption from the payment of the registration fee payable for the renewal, applied for under section 222(2)(a) and (b)(i) or (ii), has been granted under section 225	
• drawn plant	22.60
(b) otherwise	5.60

## **Part 4 Fees relating to dealer plate registration**

	<b>Fee units</b>
20 Registration fee for a dealer plate (ss 78(2)(c)(i) and 86(b)(i))—	
(a) if the registration or renewal is for a term of 1 year	621.75
(b) if the registration or renewal is for a term of 6 months	310.85

	<b>Fee units</b>
21 Surcharge for processing a registration application for a dealer plate for a term of 6 months (s 78(2)(c)(ii))	8.95
22 Surcharge for processing a renewal application for a dealer plate for a term of 6 months or if section 90(2) or (3) applies (s 90(4))	8.95
23 Administrative fee for renewal of a dealer plate's registration after the expiry day (s 92(2))	67.65

## **Part 5 Miscellaneous fees**

	<b>Fee units</b>
24 Application fee for transfer of a vehicle's registration (s 42(3)(a))	29.70
25 Administration fee for making a refund after the cancellation of a vehicle's registration under section 57(2) or 61 (s 65(4)(a))	19.40
26 Application fee for unregistered vehicle permit, for each day of the term applied for (s 73(3)(b)(i))	35.50
27 Fee for giving notice of the transfer of a personalised number plate (s 135(2)(b))	107.75
28 Application fee for customising a number plate (s 137(2))	53.90
29 Fee for giving a person an extract from the register, or vehicle-related information, about a vehicle unless item 30 applies (ss 202(1)(c) and 206(2)(a)(ii) and (b))—	
(a) if the vehicle's registration number, VIN, chassis number or engine number is supplied by the person—for each vehicle	19.00

Schedule 4

---

	<b>Fee units</b>
(b) if the name and address of the person in whose name a vehicle is registered are supplied by the person making the request but the vehicle’s registration number is not—for each list of vehicle registration numbers	11.40
30 Fee for giving a person an extract from the register, or vehicle-related information, about a vehicle if the extract or information is from archival records, certified by the chief executive or both (ss 202(1)(c) and 206(2)(a)(ii) and (b))—	
(a) if the vehicle’s registration number, VIN, chassis number or engine number is supplied by the person—for each vehicle	30.35
(b) if the name and address of the person in whose name a vehicle is registered are supplied by the person making the request but the vehicle’s registration number is not—for each list of vehicle registration numbers	30.35
31 Fee for a client user under section 203 obtaining an extract from the register about a vehicle (s 203(1)(a)(ii))—	
(a) if the client user obtains an extract about 1 vehicle by supplying the vehicle’s registration number	19.00
(b) if the client user obtains extracts about 2 or more vehicles by supplying each vehicle’s registration number in the same request—for each vehicle	11.40
(c) if the name and address of the person in whose name a vehicle is registered are supplied by the client user, but the vehicle’s registration number is not—for each list of vehicle registration numbers	11.40

---

## **Schedule 5      Vehicles for particular concessional registration fees**

section 232

### **1      Local government vehicle**

A vehicle whose registered operator is a local government.

### **2      Community service organisation vehicle**

A vehicle—

- (a) whose registered operator is a community service organisation; and
- (b) that is used on a road solely to give help to persons in distress.

### **3      Vehicle garaged in particular areas**

A vehicle that has a garage address in 1 of the following areas—

- (a) the following local government areas—
  - (i) Aurukun;
  - (ii) Doomadgee;
  - (iii) Kowanyama;
  - (iv) Pormpuraaw;
  - (v) Yarrabah;
- (b) a coastal island that is not joined to the mainland by a bridge;
- (c) the area north of the Archer River, from the western end to the eastern end of the river;
- (d) the area north of a straight line from the eastern end of the Archer River to Friendly Point.

*Editor's note—*

Friendly Point is on the east coast of Queensland north of Cooktown.

**4 Vehicle used solely to cross roads within an agricultural property**

A vehicle—

- (a) whose registered operator, or at least 1 of whose registered operators, operates an agricultural property; and
- (b) that is used solely on a road—
  - (i) within the property; and
  - (ii) that must be crossed by the vehicle to allow the property to be operated.

**5 Vehicle used solely to travel between 2 agricultural properties, or 2 mining properties, directly across the road from each other**

A vehicle, if—

- (a) the vehicle's registered operator, or at least 1 of the vehicle's registered operators, is the sole or joint operator of—
  - (i) an agricultural property, or a property used solely or partly for mining, with a frontage (the *first frontage*) to a side of a road; and
  - (ii) a separate agricultural property, or property used solely or partly for mining, with a frontage (the *second frontage*) to the opposite side of the road; and
- (b) all or part of the first frontage is directly opposite all or part of the second frontage; and
- (c) the vehicle's use on a road is solely to travel along the road, for no more than 2km per trip, between the properties.

*Example for (c)—*

travel along the road for 2km between a gated entry and exit on one of the properties to an undeveloped entry and exit on the other property

## **6 Vehicle used solely for fencing of primary producer's property**

A vehicle—

- (a) whose registered operator, or at least 1 of whose registered operators—
  - (i) is a primary producer; and
  - (ii) operates a property used for carrying on the registered operator's business as a primary producer; and
- (b) that is used solely on a road—
  - (i) within the property; or
  - (ii) onto which the property has frontage; and
- (c) that is used for the purpose of building, maintaining or removing fences.

## **7 Vehicle used solely as a mobile workshop for carrying on business of beekeeping**

A vehicle whose use on a road is solely as a mobile workshop for carrying on the vehicle's registered operator's business of beekeeping.

## **8 Vehicle used solely to cross roads within a mining property**

A vehicle—

- (a) whose registered operator, or at least 1 of whose registered operators, operates a property solely or partly used for mining; and
- (b) that is used solely on a road—

- (i) within the property; and
- (ii) that must be crossed by the vehicle to allow the mining to be carried out.

**9 Vehicle used solely to carry on business of oil, mineral or water exploration**

A vehicle—

- (a) permanently fitted with oil, mineral or water exploration equipment; and
- (b) whose registered operator carries on a business of exploring for oil, minerals or water; and
- (c) that is used on a road solely for carrying on the business.

**10 Vehicle used solely for carrying on business of prospecting in particular local government areas**

A vehicle—

- (a) whose registered operator carries on a business of prospecting in 1 or more of the local government areas mentioned in schedule 6; and
- (b) that is used on a road solely for carrying on the business.

**11 Vehicle used solely for carrying on business of well boring**

A vehicle—

- (a) whose registered operator carries on a business of well boring; and
- (b) that is—
  - (i) permanently fitted with well boring equipment; and
  - (ii) used on a road solely for carrying on the business.

---

**Schedule 6      Local government areas for  
schedule 5, section 10 for  
vehicles used solely to carry on  
business of prospecting**

schedule 5, section 10

Aurukun

Balonne

Barcaldine

Barcoo

Blackall-Tambo

Boulia

Bulloo

Burke

Carpentaria

Central Highlands, other than within a 20km radius of the post office at Emerald

Cloncurry

Cook

Croydon

Diamantina

Doomadgee

Etheridge

Flinders

Hope Vale

Isaac

Lockhart River

Longreach

Schedule 6

---

Mapoon

Maranoa, other than within a 20km radius of the post office at Roma

McKinlay

Mornington

Mount Isa, other than within a 20km radius of the principal post office

Murweh

Napranum

Northern Peninsula Area

Paroo

Quilpie

Richmond

Torres

Winton

Wujal Wujal

---

## Schedule 7      Grounds for cancellation of vehicle's registration

section 58(1)

### Part 1                      Registered vehicle of any type

- 1 A ground exists if all of the following apply—
  - (a) a defect notice is issued under the *Transport Operations (Road Use Management—Vehicle Standards and Safety) Regulation 2021* for the vehicle;
  - (b) the vehicle's registered operator contravenes the requirements of the defect notice;
  - (c) the chief executive gives the registered operator a written notice (a **warning notice**) under section 19 of the Act stating that a ground will exist to cancel the vehicle's registration at the end of the day stated in the warning notice (the **expiry day**) if the registered operator does not, within that time—
    - (i) comply with the defect notice; or
    - (ii) ask the chief executive to cancel the vehicle's registration;
  - (d) the chief executive is satisfied the registered operator has not complied with all the requirements of the defect notice by the expiry day;
  - (e) the registered operator has not asked the chief executive to cancel the vehicle's registration.
- 2 A ground exists if all of the following apply—
  - (a) an authorised officer asks the owner or registered operator to have the vehicle inspected under section 36 of the Act;
  - (b) the owner or registered operator fails to comply with the request;

Schedule 7

---

- (c) the chief executive gives the registered operator a written notice (a **warning notice**) under section 19 of the Act stating that a ground will exist to cancel the vehicle's registration at the end of the day stated in the warning notice (the **expiry day**) if, within that time—
    - (i) the owner or registered operator does not comply with the request; or
    - (ii) the registered operator does not ask the chief executive to cancel the vehicle's registration;
  - (d) the chief executive is satisfied the request has not been complied with by the expiry day;
  - (e) the registered operator has not asked the chief executive to cancel the registration.
- 3 A ground exists if both of the following apply—
- (a) an authorised officer asks the owner, registered operator or person in control of the vehicle not to use the vehicle, or permit it to be used, on a road or public place under section 37 of the Act;
  - (b) the owner, registered operator or person in control of the vehicle does not comply with the request.
- 4 A ground exists if both of the following apply—
- (a) a police officer requires the owner or registered operator of the vehicle not to use the vehicle, or permit it to be used, on a road under the *Police Powers and Responsibilities Act 2000*, section 66(1);
  - (b) the owner or registered operator of the vehicle contravenes the requirement.
- 5 A ground exists if all of the following apply—
- (a) the vehicle, or a part of the vehicle, is subject to the *Consumer Goods (Motor Vehicles With Affected Takata Airbag Inflators and Specified Spare Parts) Recall Notice 2018* (Cwlth) (the **recall notice**);
  - (b) the ACCC tells the chief executive, in writing, that—

- (i) the supplier of the vehicle is considered to have complied with its obligations to replace affected airbag inflators under the recall notice; and
  - (ii) an affected airbag inflator fitted within the vehicle has not been replaced in compliance with the recall notice;
- (c) the chief executive reasonably believes that each affected airbag inflator fitted within the vehicle has not been replaced in compliance with the recall notice.

## Part 2

### Registered vehicle that is a heavy vehicle

- 6 A ground exists if all of the following apply—
- (a) the registered operator or person in charge of the vehicle is required by a notice under the Heavy Vehicle National Law (Queensland), section 522 to produce the vehicle for inspection;
  - (b) the registered operator or person in charge of the vehicle fails to comply with the requirement;
  - (c) the chief executive gives the registered operator a written notice (a **warning notice**) under section 19 of the Act stating that a ground will exist to cancel the vehicle’s registration at the end of 14 days after the date of the warning notice (the **expiry day**) if, by the expiry day—
    - (i) the registered operator or person in charge of the vehicle does not comply with the requirement; or
    - (ii) the registered operator does not ask the chief executive to cancel the vehicle’s registration;
  - (d) the chief executive is satisfied the requirement has not been complied with by the expiry day;
  - (e) the registered operator has not asked the chief executive to cancel the registration.

- 7 A ground exists if all of the following apply—
- (a) a vehicle defect notice is issued under the Heavy Vehicle National Law (Queensland), section 526 for the vehicle;
  - (b) the vehicle defect notice has not been cleared by the Regulator under section 530 of that Law;
  - (c) the chief executive gives the registered operator a written notice (the *warning notice*) under section 19 of the Act stating that a ground will exist to cancel the vehicle's registration at the end of 14 days after the date of the warning notice (the *expiry day*) if, by the expiry day—
    - (i) the vehicle defect notice is not cleared by the Regulator under section 530 of that Law; or
    - (ii) the registered operator does not ask the chief executive to cancel the vehicle's registration;
  - (d) the chief executive is satisfied the vehicle defect notice has not been cleared by the Regulator by the expiry day;
  - (e) the registered operator has not asked the chief executive to cancel the registration.

---

## Schedule 8 Dictionary

### section 3

**ACCC** means the Australian Competition and Consumer Commission established by the *Competition and Consumer Act 2010* (Cwlth), section 6A.

**accessory** means a bike rack or other device attached to the front or rear of a vehicle.

**accessory plate**—

- (a) for a tow truck—see section 141(4); or
- (b) for another vehicle—see section 139(4).

**acquirer**, of a registered vehicle, for part 3, division 3, see section 41.

**acquisition**, of a registered vehicle, for part 3, division 3, see section 41.

**affected airbag inflator** means an Affected Takata Airbag Inflator under the *Consumer Goods (Motor Vehicles With Affected Takata Airbag Inflators and Specified Spare Parts) Recall Notice 2018* (Cwlth), section 4.

**agricultural implement** means a vehicle without its own automotive power that is built to perform agricultural tasks.

*Examples*—

auger, conveyor, empty field bin, irrigating equipment, machinery that is fully carried on the three-point linkage of a tractor

**agricultural machine** means a machine with its own automotive power that is—

- (a) built to perform agricultural tasks; and
- (b) used for agricultural purposes.

*Example*—

a tractor or harvester being used for agricultural purposes

**AIS** means an AIS under the *Transport Operations (Road Use Management—Accreditation and Other Provisions) Regulation 2015*.

**ambulance vehicle** means a motor vehicle used solely for transporting, and giving emergency treatment and pre-hospital patient care to, sick or injured persons by an ambulance service or hospital.

**application**, for part 9, see section 192.

**approved examiner** see the *Transport Operations (Road Use Management—Accreditation and Other Provisions) Regulation 2015*, schedule 7.

**approved written-off vehicle examiner** see section 166(3).

**approved written-off vehicle nominee** see section 166(4).

**articulated bus** means a bus with 2 or more rigid sections connected to each other in a way that allows—

- (a) passenger access between the sections; and
- (b) rotary movement between the sections.

**ATM** (aggregate trailer mass), for a trailer—

- (a) means the maximum mass, specified by the manufacturer, for the loaded trailer; and
- (b) includes any mass imposed on the vehicle towing the trailer when they are on a horizontal surface.

**auctioneer** means a person who carries on a business that includes selling, attempting to sell or offering for sale or resale notifiable vehicles, or parts of notifiable vehicles having a chassis number or VIN, by auction.

**authorised statutory entity**, for part 10, division 2, see section 201.

**auto parts dismantler** means a person who carries on the business of—

- (a) demolishing or dismantling vehicles, vehicle parts or accessories; or

- (b) buying vehicles and substantially demolished or substantially dismantled vehicles and selling substantially demolished or substantially dismantled vehicles, whether or not the person also sells vehicle parts or accessories.

**axle** means 1 or more shafts positioned in a line across a vehicle, on which 1 or more wheels intended to support the vehicle turn.

**axle group** means a single axle group, tandem axle group, twinsteer axle group, tri-axle group, quad-axle group or multi-axle group.

**B-double lead trailer** means a semitrailer that is nominated for use as the lead trailer in a B-double.

**B-triple** means a combination consisting of a prime mover towing 3 semitrailers.

**B-triple lead trailer** means a semitrailer that is nominated for use as the lead trailer in a B-triple.

**B-triple middle trailer** means a semitrailer that is nominated for use as the second trailer in a B-triple.

**bus** means a motor vehicle built mainly to carry 10 or more seated adults, including the driver.

**bus (type 1)** means a rigid bus with 2 axles and an MRC of not more than 12t.

**bus (type 2)** means a rigid bus with—

- (a) 2 axles and an MRC of more than 12t; or
- (b) 3 or more axles.

**caravan**—

- (a) means an enclosed trailer designed for people to live in; but
- (b) does not include a camper trailer.

**card holder** means a person who holds—

- (a) a pensioner concession card; or
- (b) a seniors card.

**category 1 vehicle** means a vehicle with a GVM, GCM or ATM of 4.5t or less.

**category 2 vehicle** means a vehicle with a GVM, GCM or ATM of more than 4.5t.

**certificate of modification** means—

- (a) for the modification of a heavy vehicle—a certificate approving the modification given, or taken to have been given, under the Heavy Vehicle National Law (Queensland), section 86(2)(a) or 87(3)(a) or a corresponding law; or

*Note—*

See the Heavy Vehicle National Law (Queensland), section 748 for things taken to have effect under that Law.

- (b) for the modification of a light vehicle—a certificate of modification under the *Transport Operations (Road Use Management—Vehicle Standards and Safety) Regulation 2021* for the modification.

**chassis number**, of a vehicle, means an identification number of the vehicle's chassis that is permanently marked on the chassis or another part of the vehicle, but does not include the vehicle's VIN.

**community service organisation** means an organisation established for the purpose of providing help to persons in distress.

*Examples of help—*

care, relief, support, housing, education or instruction

**compliance plate** means a plate authorised to be placed on a vehicle, or taken to have been placed on a vehicle, under—

- (a) the repealed *Motor Vehicle Standards Act 1989* (Cwlth); or
- (b) the *Road Vehicle Standards (Consequential and Transitional Provisions) Act 2018* (Cwlth), schedule 3, part 3.

**concessionally registered** means registered with concessional registration.

***concessional registration***, of a vehicle, means registration of the vehicle for which a concessional registration fee is paid under an approval granted under section 230.

***conditionally registered*** means registered with a type of conditional registration.

***conditionally registrable vehicle*** means a vehicle mentioned in section 18(2) to which the conditional registration guideline or a heavy vehicle standards exemption applies.

***conditional registration***, of a vehicle, see section 21(4).

***conditional registration guideline*** means the safe movement guideline called ‘Safe movement guideline for conditionally registering a vehicle in Queensland’, issued and published by the chief executive under the *Transport Operations (Road Use Management—Vehicle Standards and Safety) Regulation 2021*, section 53.

***converter dolly*** means a trailer with a fifth wheel coupling designed to support a semitrailer for hauling purposes.

***CTP insurance policy*** see the *Motor Accident Insurance Act 1994*, section 4.

***CTP insurance premium*** means the insurance premium payable under the *Motor Accident Insurance Act 1994* for an insurance certificate under that Act.

***CTP insurer*** means a licensed insurer under the *Motor Accident Insurance Act 1994*, section 4 who issues CTP insurance policies.

***current postal address***, for a person, means a postal address a person has given the department, whether or not for a purpose of this regulation, if the person has not given the department notice requiring the department to stop using the address.

***customer communication***, for part 9, see section 192.

***customised number plate*** see section 137(5).

***damaged*** includes significantly deteriorated.

***dealer*** means—

Schedule 8

---

- (a) the holder of a motor dealer licence under the *Motor Dealers and Chattel Auctioneers Act 2014* or an equivalent licence or other authority under a corresponding law to that Act; or

*Note—*

See also the *Motor Dealers and Chattel Auctioneers Act 2014*, schedule 3.

- (b) a person whose business is the sale of new motor vehicles, or new or used trailers.

***dealer plate*** means a number plate designated by the chief executive as a dealer plate under section 77.

***dealer's premises*** means premises where a dealer carries on business—

- (a) including any part of the premises used for car parking or for inspecting, repairing, servicing or cleaning motor vehicles; and
- (b) excluding any road-related area adjacent to the premises.

***dealer's stock*** means a motor vehicle kept at a dealer's premises for the purpose of sale or display for sale, and includes a motor vehicle—

- (a) being inspected, repaired, serviced or cleaned before being sold or displayed for sale; and
- (b) that has been sold by the dealer and is ready for delivery to the purchaser.

***dealer (trailer trade) plate***, for part 4, division 2, subdivision 4, see section 95.

***defence force member*** means—

- (a) a person on full-time permanent service with the Australian Defence Force; or
- (b) a person on full-time duty with the Australian Defence Force Reserve.

***departmental inspection site*** means a place at which a vehicle is inspected by an authorised officer for the purpose of issuing an inspection certificate.

***departmental service centre*** means a place at which services are provided by, or on behalf of, the department relating to the registration of vehicles.

***direct debit arrangement*** means an arrangement, on terms approved by the chief executive, that allows an amount payable by a person to the chief executive to be paid, by direct debit, from an account the person holds with a financial institution.

***disaster assistance area***, for part 8, division 1, see section 178.

***disaster assistance arrangement***, for part 8, division 1, see section 178.

***disposal***, of a vehicle, for part 3, division 3, see the *Transport Operations (Road Use Management—Vehicle Standards and Safety) Regulation 2021*, schedule 4.

***disposal notice***, for part 3, division 3, see section 44(1)(b).

***disposer***, of a registered vehicle, for part 3, division 3, see section 41.

***dog trailer*** means a trailer with—

- (a) 1 axle group or a single axle at the front that is connected to the towing vehicle by a drawbar; and
- (b) 1 axle group or single axle at the rear.

***drawbar*** means a part of a trailer, other than a semitrailer, that connects the trailer body to a coupling for towing purposes.

***drawn plant***—

- (a) means a machine built on a trailer base; but
- (b) does not include an agricultural implement.

***drought declaration***, for part 8, division 2, see section 185.

***drought-declared area***, for part 8, division 2, see section 185.

***drought-declared property***, for part 8, division 2, see section 185.

***eligible vehicle***—

- (a) for part 8, division 1—see section 179; or
- (b) for part 8, division 2—see section 186.

***engine capacity***, for a motorbike, means the engine capacity for the motorbike—

- (a) under the specifications of the motorbike’s manufacturer for the motorbike; or
- (b) stated in a LAM test report for the motorbike.

***equivalently registered*** means registered, under a corresponding law to a transport Act, in a person’s name, in a register equivalent to the register required to be kept by the chief executive under part 5.

***exempt vehicle*** see section 4.

***farm plate vehicle*** means a concessionally registered vehicle for which a registration fee was paid under schedule 2, part 2, item 11 or schedule 3, part 4, item 30.

***fifth wheel coupling***—

- (a) means a device used with a prime mover, semitrailer or a converter dolly to—
  - (i) permit quick coupling and uncoupling; and
  - (ii) provide for articulation; but
- (b) does not include the parts of a semitrailer known as the upper rotating element and the kingpin.

***fire and emergency appliance*** means a vehicle—

- (a) built or modified for—
  - (i) fighting fires; or
  - (ii) supporting or performing rescue operations; and
- (b) operated by authorised fire officers under the *Fire Services Act 1990*.

***freestyle motocross*** means a competition to compare competitors' skills, or an event to demonstrate a rider's skills, in performing motorbike acrobatics on a motorbike that has been ridden off a ramp.

***freestyle motocross area*** means an area not dedicated to public use as a road, from which other traffic is excluded while it is being used to perform the riding involved in freestyle motocross.

***garage address***, of a vehicle, see section 5.

***gas compliance document***, for a gas system in a vehicle, means—

- (a) for a new vehicle—the certificate or plate for the system required under the *Petroleum and Gas (Safety) Regulation 2018*, section 105 or 115 before the vehicle may be offered for sale; or
- (b) for a used vehicle—the certificate for the system required under the *Petroleum and Gas (Safety) Regulation 2018*, section 106 or 116 to be given to the person to whom the vehicle is sold or transferred before the person takes possession of the vehicle.

***gas system*** see the *Petroleum and Gas (Production and Safety) Act 2004*, schedule 2.

***GCM*** (gross combination mass)—

- 1 The *GCM* of a motor vehicle is the maximum loaded mass for the motor vehicle and any vehicles it may lawfully tow—
  - (a) stated for the motor vehicle in the RAV; or
  - (b) if the maximum loaded mass is not stated in the way mentioned in paragraph (a)—
    - (i) stated on the motor vehicle's compliance plate; or
    - (ii) if the motor vehicle does not have a compliance plate or the maximum loaded mass is not stated on the compliance plate or is illegible—

- (A) stated by the motor vehicle's manufacturer in another place; or
  - (B) if the motor vehicle's manufacturer can not be identified—stated by the chief executive or the corresponding authority under a corresponding law to the Act.
- 2 However, if a motor vehicle has been modified, the *GCM* of the motor vehicle is the maximum loaded mass for the motor vehicle and any vehicles it may lawfully tow—
- (a) stated on the certificate of modification or modification plate for the modification; or
  - (b) if the maximum loaded mass is not stated in the way mentioned in paragraph (a)—stated by the chief executive or the corresponding authority under a corresponding law to the Act; or
  - (c) if the maximum loaded mass is not stated in any of the ways mentioned in paragraph (a) or (b)—applying to the motor vehicle under paragraph 1.

*give*, in relation to information, for part 10, division 2, see section 201.

***GTMR*** (gross trailer mass rating), of a trailer, means the mass transmitted to the ground by the axles of the trailer when the trailer is—

- (a) coupled to a towing vehicle; and
- (b) carrying its maximum load, distributed as uniformly as possible over the trailer's load bearing area.

***heavy primary production vehicle*** means a prescribed heavy vehicle that is—

- (a) owned by a primary producer; and
- (b) used only for carrying on the primary producer's business as a primary producer.

**heavy vehicle standards exemption** means a vehicle standards exemption (notice) or vehicle standards exemption (permit) under the Heavy Vehicle National Law (Queensland) applying—

- (a) in relation to particular requirements under the heavy vehicle standards under that Law; and
- (b) for the purposes of conditional registration.

**historic ambulance vehicle** means a vehicle, previously used as an ambulance vehicle, that is currently used for display by an ambulance service or historical ambulance society.

**historic firefighting equipment** means a vehicle, previously used for firefighting, that is currently used for display by a historical fire brigade society.

**identifying number**, of a vehicle, means the vehicle's—

- (a) chassis number; or
- (b) engine number; or
- (c) VIN.

**information**, for part 9, see section 192.

**insolvency entity**, for part 10, division 2, see section 201.

**inspection approval** see section 165(2).

**inspection certificate** means an inspection certificate under the *Transport Operations (Road Use Management—Vehicle Standards and Safety) Regulation 2021*.

**insurer** means a body corporate authorised under the *Insurance Act 1973* (Cwlth) to carry on insurance business.

**interstate register**, for part 10, division 2, see section 201.

**LAM information**, for a motorbike, for part 13, division 1, see section 214.

**LAM list** see section 218(1).

**LAM test report** see section 215.

**last registered operator**, of a vehicle or for a dealer plate for which registration has expired or been cancelled, means the

registered operator of the vehicle or for the dealer plate immediately before the expiry or cancellation.

**late-model vehicle** means a vehicle that is not more than 16 years old, worked out by counting from—

- (a) the last day of the month in which the vehicle was manufactured; or
- (b) if the month in which the vehicle was manufactured is not known—the last day of the year in which the vehicle was manufactured.

**lead trailer**, in a combination including a prime mover, means the trailer that is, or that is to be, attached to the prime mover.

**learner approved motorbike** see section 218(3).

**light vehicle** see the *Transport Operations (Road Use Management—Vehicle Standards and Safety) Regulation 2021*, section 5.

**limited access registration**, for a vehicle, see section 21(3)(a).

**load**, of a vehicle, includes—

- (a) anything normally taken from the vehicle when it is not in use; and
- (b) anything that may fall from the vehicle when it is in motion.

**loaded mass**, of a vehicle, means the vehicle's mass together with the mass of the vehicle's load transmitted to the ground.

**local government area** means a local government area under the *Local Government Act 2009*.

**long combination truck** means a truck nominated to tow 2 or more trailers.

**loss adjuster** means a person who, in the ordinary course of the person's business, assesses the extent of loss or damage involving a vehicle for another person.

**low loader** means a gooseneck semitrailer with a loading deck not more than 1m above the ground.

**low loader dolly** means a trailer that—

- 
- (a) is of the type usually coupled between a prime mover and a low loader; and
  - (b) consists of a gooseneck rigid frame; and
  - (c) does not carry a load directly on itself; and
  - (d) is equipped with 1 or more axles, a kingpin and a fifth wheel coupling.

**maximum engine power**, for a motorbike, means the maximum engine power for the motorbike—

- (a) under the specifications of the motorbike’s manufacturer for the motorbike; or
- (b) stated in a LAM test report for the motorbike.

**medium combination truck** means a truck, other than a short combination truck, nominated to haul 1 trailer.

**mobile machinery**—

- (a) means a motor vehicle whose machinery is incorporated in the body of the vehicle; but
- (b) does not include—
  - (i) a truck, semitrailer or prime mover; or
  - (ii) a tow truck; or
  - (iii) a conditionally registrable vehicle.

**modification plate** means—

- (a) for the modification of a heavy vehicle—a plate or label relating to the modification fitted or affixed, or taken to have been fitted or affixed, to the vehicle under the Heavy Vehicle National Law (Queensland), section 86(2)(b) or 87(3)(b) or a corresponding law; or

*Note*—

See the Heavy Vehicle National Law (Queensland), section 748 for things taken to have effect under that Law.

- (b) for the modification of a light vehicle—a modification plate for the modification under the *Transport Operations (Road Use Management—Vehicle Standards and Safety) Regulation 2021*.

***motorised caravan*** means a motor vehicle designed mainly for people to live in.

***motorised golf buggy*** means a motor vehicle that is designed as transport for persons playing, or persons associated with persons playing, golf.

***motor race*** means—

- (a) a race involving motor vehicles; or
- (b) a practice or time trial for a race or competition involving 1 or more motor vehicles.

***MRC*** (mass rating for charging), of a vehicle, means the maximum permissible mass of the vehicle and its load—

- (a) stated in the RAV as the GVM, GTMR or ATM of the vehicle; or
- (b) if the maximum permissible mass of the vehicle and its load is not stated as mentioned in paragraph (a)—shown on the vehicle’s compliance plate as the GVM, GTMR or ATM of the vehicle; or
- (c) if the maximum permissible mass of the vehicle and its load is not stated or shown as mentioned in paragraph (a) or (b)—stated by the chief executive or the corresponding authority under a corresponding law to the Act, having regard to the design and construction of—
  - (i) the vehicle; or
  - (ii) any of its components.

***multi-axle group*** means—

- (a) for a dog trailer—5 or more axles at the front or at the rear, or 5 or more axles at the front and 5 or more axles at the rear; or
- (b) for a pig trailer—5 or more axles near the middle of the load carrying surface of the trailer; or
- (c) for a semitrailer—5 or more axles towards the rear of the trailer; or

- (d) for a B-double lead trailer or B-triple lead trailer or B-triple middle trailer—5 or more axles towards the rear of the trailer; or
- (e) for a converter dolly or low loader dolly—5 or more axles located under the fifth wheel coupling.

***multi-combination prime mover*** means a prime mover nominated to haul 2 or more trailers.

***national heavy vehicle number plate*** means a plate designed to be attached to a category 2 vehicle to identify the vehicle.

***natural disaster relief measure***, for part 8, division 1, see section 178.

***natural disaster relief notice***, for part 8, division 1, see section 180(1).

***NEVDIS***, for part 10, division 2, see section 201.

***nominated***, in relation to the configuration or purpose of use of a registered vehicle, means the configuration or purpose of use nominated for the vehicle in the most recent application for registration, or notice given under section 68(2), for the vehicle.

***nominated primary producer***, for a heavy primary production vehicle, see section 228A(2) and (3).

***notifiable information***, for a written-off vehicle, means—

- (a) the written-off vehicle's chassis number or VIN; and
- (b) the written-off vehicle's engine number, if available; and
- (c) if the written-off vehicle has been assessed as a total loss—when the vehicle was assessed to be a total loss; and
- (d) whether the written-off vehicle is a repairable write-off or a statutory write-off; and
- (e) the type, location and severity of the damage to the written-off vehicle; and
- (f) details of the person providing the information mentioned in paragraphs (a) to (e).

***notifiable vehicle*** means—

- (a) a vehicle that—
  - (i) is a late-model vehicle of 1 of the following types—
    - (A) a motor vehicle with a GVM of not more than 4.5t;
    - (B) a motorbike;
    - (C) a caravan;
    - (D) a trailer with an ATM of more than 4.5t; and
  - (ii) complies with the requirements of the Australian Design Rules under the *Road Vehicle Standards Act 2018* (Cwlth) applying to the vehicle; or
- (b) a vehicle of another type notified by the chief executive by gazette notice.

***notifier*** means any of the following—

- (a) an insurer;
- (b) a self-insurer;
- (c) a loss adjuster;
- (d) a dealer;
- (e) an auctioneer;
- (f) an auto parts dismantler.

***observed trial area*** means an area not dedicated to public use as a road, from which other traffic is excluded while it is being used as a course for a competition to compare competitors' skills, or an event to demonstrate a rider's skills, in riding a motorbike around a marked course, 1 at a time.

***pensioner concession card*** see the *Social Security Act 1991*, section 23.

***personal information***, about a vehicle's current or previous registered operator, for part 10, division 2, see section 201.

***personalised number plate*** see section 132(1).

***pig trailer*** means a trailer—

- (a) with 1 axle group or a single axle near the middle of its load carrying surface; and
- (b) that is connected to the towing vehicle by a drawbar.

***pole-type trailer*** means a trailer that—

- (a) is attached to a towing vehicle by a pole or an attachment fitted to a pole; and
- (b) is ordinarily used for transporting loads that are generally capable of supporting themselves like beams between supports.

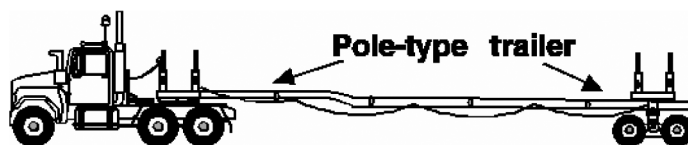

*Examples of loads generally capable of supporting themselves like beams between supports—*

logs, pipes, structural members, other long objects

***power-to-weight ratio***, for a learner approved motorbike, is a ratio—

- (a) expressed in kilowatts per tonne; and
- (b) worked out using the following formula—

$$\left( \frac{M}{T + 90\text{kg}} \right) \times 1000$$

where—

***M*** means the maximum engine power, in kilowatts, for the learner approved motorbike.

***T*** means the tare mass, in kg, of the learner approved motorbike.

***pre-1994 pensioner*** means a person who holds, and has continuously held, a pensioner concession card that was issued in Queensland before 1 July 1994.

***prescribed evidence***, of an inspection certificate, means—

- (a) for an inspection certificate issued manually—the certificate; or
- (b) otherwise—a copy of the certificate or the unique number for the certificate under the *Transport Operations (Road Use Management—Vehicle Standards and Safety) Regulation 2021*.

***prescribed heavy vehicle*** means—

- (a) a prime mover or truck with a GVM of at least 6t; or
- (b) a trailer with an MRC of more than 4.5t.

***prescribed information***, for a vehicle, for part 10, division 1, see section 198.

***prescribed private use vehicle*** means a category 1 vehicle mentioned in schedule 2, item 1, 2, 3 or 4, if the vehicle's purpose of use is recorded in the register as private purposes.

***prescribed service person*** means a person residing in Queensland who—

- (a) is, or has previously been, a defence force member; and
- (b) has been assessed—
  - (i) under the *Veterans' Entitlements Act 1986* (Cwlth) as having a degree of incapacity of at least 70%; or
  - (ii) under the *Military Rehabilitation and Compensation Act 2004* (Cwlth) as having an impairment constituting at least 50 impairment points.

***primary produce*** means raw material for clothing or food derived from—

- (a) agriculture; or
- (b) dairying; or
- (c) fishing; or

- (d) the raising of livestock; or
- (e) viticulture.

**primary producer** means a person who carries on a business in which—

- (a) the main activity of the business is the production of primary produce; and
- (b) any transportation of primary produce is incidental to the main activity.

**production motorbike** means a motorbike that—

- (a) is manufactured and marketed in volume for normal road use; and
- (b) complies with the vehicle laws applying to the motorbike.

**quad-axle group** means a group of 4 axles, in which the horizontal distance between the centre-lines of the outermost axles is more than 3.2m but not more than 4.9m.

**racing track** means a circuit or track used as a course for a motor race or motor race driver training, if—

- (a) other traffic is excluded from the circuit or track during its use for the race or training; and
- (b) the circuit or track is not dedicated to public use as a public road.

**racing vehicle** means a vehicle that is used in a motor race or for motor race driver training.

**RAV** means the Register of Approved Vehicles under the *Road Vehicle Standards Act 2018* (Cwlth).

**recognised primary producer** see section 228A(1).

**recorded expiry day**, for the registration of a vehicle or dealer plate, means the day recorded in the register as the day the registration expires.

**register**, as a noun, means the register of vehicles and number plates required to be kept under section 111.

**registered dealer plate** means a dealer plate for which there is current registration.

**registered operator**—

- (a) generally, of a vehicle or for a dealer plate—see section 6; and
- (b) for part 7, division 2—see section 145.

**registered vehicle** see section 7(1).

**registration**, for a vehicle or dealer plate, means the recording of the vehicle or dealer plate, in a person's name, in the register.

**registration administration fee**, for a vehicle or a type of conditional registration, means the registration administration fee stated in schedule 4, part 3 for the vehicle or type.

**registration application**—

- (a) for a vehicle, means an application for registration of the vehicle in a person's name made under section 19; or
- (b) for a dealer plate, means an application for registration of the plate in a person's name made under section 78.

**registration certificate**—

- (a) for a vehicle—means a certificate given by the chief executive that includes the details mentioned in section 27(2) about the vehicle; or
- (b) for a dealer plate—means a certificate given by the chief executive that includes—
  - (i) the registration number for the dealer plate; and
  - (ii) the details required for the dealer plate under section 112(1).

**registration fee**—

- (a) for a vehicle—means the fee for registering the vehicle mentioned in section 220(1), (2) or (3); or
- (b) for a dealer plate—means the fee for registering the dealer plate stated in schedule 4, part 4.

---

**registration number**, for a vehicle, dealer plate or personalised number plate, means a distinguishing number, assigned by the chief executive—

- (a) to identify the vehicle or plate; and
- (b) displayed, or intended for display—
  - (i) for a vehicle—on the vehicle’s number plate; or
  - (ii) for a dealer plate or personalised number plate—on the plate.

**registration-related amount**—

- (a) for a renewal of a vehicle’s registration, means the total of—
  - (i) the fees mentioned in section 33(1)(a) and (b) for the vehicle and registration; and
  - (ii) a CTP insurance premium payable in relation to the registration under section 33(1)(c); or
- (b) for a renewal of a dealer plate’s registration, means the total of—
  - (i) the application fee for the renewal; and
  - (ii) a CTP insurance premium payable in relation to the registration under section 86(b)(iii).

**renewal application**—

- (a) for a vehicle, means an application for renewal of the vehicle’s registration in a person’s name under section 32; or
- (b) for a dealer plate, means an application for renewal of the plate’s registration in a person’s name under section 85.

**repairable write-off**—

- (a) generally—means a notifiable vehicle that is a total loss but is not a statutory write-off; and
- (b) in relation to a written-off vehicle inspection or a written-off vehicle inspection report—includes a vehicle with a chassis number or VIN that is the same as the

chassis number or VIN of a vehicle recorded in the register, or in a register kept under a corresponding law to this regulation, as a repairable write-off.

**responsible person**, for a notifiable vehicle, for part 7, division 2, see section 145.

**road-related area** see the Queensland Road Rules, section 13.

**safety recall agency**, for part 10, division 2, see section 201.

**sale**, of a vehicle, includes—

- (a) the hiring of the vehicle on hire-purchase; and
- (b) the leasing of the vehicle.

**seasonal heavy vehicle** means a prescribed heavy vehicle if—

- (a) the registered operator of the vehicle—
  - (i) is a primary producer; and
  - (ii) uses the vehicle only as a heavy primary production vehicle; or
- (b) the vehicle is used only seasonally, and only to transport primary produce from a farm or fishing waters to a place where the primary produce is—
  - (i) loaded onto a train, vessel or another vehicle; or
  - (ii) stored before being processed; or
  - (iii) first subjected to processing.

**self-insurer** means an entity that owns 5 or more notifiable vehicles for which there is no insurance policy with an insurer covering loss or damage.

**semitrailer** means a trailer, including a pole-type trailer, that has—

- (a) 1 axle group or a single axle towards the rear; and
- (b) a means of attachment to a prime mover or converter dolly that results in some of the load being imposed on the prime mover or converter dolly.

**seniors card** means a Queensland Government seniors card.

***short combination prime mover*** means a prime mover nominated to tow 1 semitrailer.

***short combination truck*** means a truck nominated to haul 1 trailer, if the combination has—

- (a) 6 or less axles; and
- (b) a total mass of not more than 42.5t.

***single axle*** means an axle not forming part of an axle group.

***single axle group*** means a group of 2 or more axles, in which the horizontal distance between the centre-lines of the outermost axles is less than 1m.

***small trailer*** means a trailer with an ATM of not more than 1.02t.

***special edition number plate*** means a number plate, other than a personalised number plate, showing a design or theme representing an event, occasion or achievement.

***special interest vehicle*** means—

- (a) a vehicle, other than a trailer with a GVM of less than 4.5t or a caravan with a GVM of less than 4.5t, that is—
  - (i) at least 30 years old; or
  - (ii) an historic ambulance vehicle or historic firefighting equipment; or
  - (iii) a street rod vehicle; or
- (b) a bus—
  - (i) that is at least 25 years old; and
  - (ii) with a GVM over 5t.

***special plate*** means a customised number plate or personalised number plate.

***special purpose vehicle*** means—

- (a) any of the following vehicles, other than a vehicle that may only be conditionally registered—
  - (i) a forklift;

Schedule 8

---

- (ii) a straddle carrier;
- (iii) a mobile cherry picker;
- (iv) a mobile crane; or
- (b) a vehicle that has been built, or permanently modified, for a purpose other than carrying goods or passengers, but does not include—
  - (i) a vehicle mentioned in paragraph (a); or
  - (ii) a caravan; or
  - (iii) a motorised caravan; or
  - (iv) a mobile library; or
  - (v) a mobile laboratory; or
  - (vi) a mobile billboard.

***special purpose vehicle (type o)*** means a special purpose vehicle, other than a special purpose vehicle (type p), that—

- (a) is built, or permanently modified, primarily for use on roads; and
- (b) has at least 1 axle or axle group loaded above the mass limits stated in the Heavy Vehicle (Mass, Dimension and Loading) National Regulation, schedule 1, part 2, table 1.

***special purpose vehicle (type p)*** means a special purpose vehicle, other than a conditionally registrable vehicle, built or permanently modified for—

- (a) off-road use; or
- (b) use on a road-related area; or
- (c) use on an area of road that is under construction.

***special purpose vehicle (type t)*** means a special purpose vehicle, other than a special purpose vehicle (type p), that—

- (a) is built, or permanently modified, primarily for use on roads; and
- (b) has no axle or axle group loaded above the mass limits stated in the Heavy Vehicle (Mass, Dimension and

Loading) National Regulation, schedule 1, part 2, table 1.

*Examples of special purpose vehicle (type t)—*

boring machinery, fire-engine, mobile crane and truck-mounted concrete pump

**statutory write-off** means a notifiable vehicle that is a total loss because of—

- (a) damage by corrosion; or
- (b) damage that satisfies the statutory write-off assessment criteria for the vehicle.

**statutory write-off assessment criteria**, for a notifiable vehicle, means—

- (a) if the notifiable vehicle has a GVM of not more than 4.5t—the criteria stated in the document called ‘Damage assessment criteria for the classification of light vehicle statutory write-offs’ published by Austroads; or
- (b) if the notifiable vehicle has an ATM of not more than 4.5t—the criteria stated in the document called ‘Damage assessment criteria for the classification of heavy vehicle statutory write-offs’ published by Austroads; or
- (c) otherwise—the criteria stated in the document called ‘Damage assessment criteria for the classification of statutory write-offs—motorbikes, caravans, heavy trailers and other vehicles’, published by the department.

**street rod vehicle** means a motor vehicle modified for safe road use that—

- (a) has a body and frame built before 1949; or
- (b) is a replica of a motor vehicle whose body and frame were built before 1949.

**supporting material**, for an eligible vehicle, for part 8, division 2, see section 185.

**tandem axle group** means a group of at least 2 axles, in which the horizontal distance between the centre-lines of the outermost axles is at least 1m but not more than 2m.

Schedule 8

---

***tare mass***, for a motorbike, means the mass of the motorbike—

- (a) with all fluid reservoirs on the motorbike, other than the fuel tank, filled to a normal operating level; and
- (b) with the fuel tank empty; and
- (c) with all standard equipment and any optional items of equipment fitted; and
- (d) without the weight of a motorbike rider or a passenger.

***total loss*** means a notifiable vehicle—

- (a) damaged by corrosion to the extent that the vehicle's fair salvage value, when added to the cost of repairing the vehicle for use on a road or road-related area, would be more than the fair market value for a vehicle of equivalent make, model and year of manufacture that is not damaged by corrosion; or
- (b) damaged by accident, collision, demolition, dismantling, fire, flood, trespass or other event to the extent that the vehicle's fair salvage value, when added to the cost of repairing the vehicle for use on a road or road-related area, would be more than the vehicle's fair market value immediately before the event that caused the damage.

***tow truck*** means a motor vehicle that is—

- (a) equipped with a lifting or loading device capable of being used for the towing of a vehicle; and
- (b) used mainly for carrying on a business of towing abandoned, disabled or damaged vehicles.

***track-related area*** means an area—

- (a) adjacent to a racing track where a racing vehicle is parked or driven for a purpose associated with a motor race or motor race driver training; and
- (b) not dedicated to public use as a road.

***tractor*** means a motor vehicle, used for towing purposes, that is not—

- (a) designed to carry passengers or goods, other than its own fuel or water; or
- (b) a tow truck.

**traffic improvement fee**, for a category 1 vehicle, other than a trailer, means the fee stated in schedule 4, item 17 for the vehicle.

**tri-axle group** means a group of at least 3 axles, in which the horizontal distance between the centre-lines of the outermost axles is more than 2m but not more than 3.2m.

**truck** means a rigid motor vehicle built mainly as a load-carrying vehicle.

**truck (type 1)** means a truck with—

- (a) 2 axles and an MRC of not more than 12t; or
- (b) 3 axles and an MRC of not more than 16.5t; or
- (c) 4 or more axles and an MRC of not more than 20t.

**truck (type 2)** means a truck with—

- (a) 2 axles and an MRC of more than 12t; or
- (b) 3 axles and an MRC of more than 16.5t; or
- (c) 4 or more axles and an MRC of more than 20t.

**twinsteer axle group** means a group of 2 axles—

- (a) with single tyres; and
- (b) fitted to a motor vehicle; and
- (c) connected to the same steering mechanism; and
- (d) the horizontal distance between the centre-lines of which is at least 1m but not more than 2m.

**unregistered vehicle** see section 7(2).

**unregistered vehicle permit** see section 73(1).

**unrestricted access registration**, for a vehicle, see section 21(3)(c).

**use**, of a vehicle on a road, includes parking the vehicle on the road.

**vehicle law** see section 8.

**vehicle-related information**, for a vehicle, for part 10, division 2, see section 201.

**VIN**, of a vehicle, means the unique vehicle identification number assigned to the vehicle.

**walking speed equipment** means a motor vehicle—

- (a) used for construction, maintenance or warehouse operation; and
- (b) designed mainly for use outside the road system; and
- (c) incapable of going faster than 10km/h.

**written-off vehicle** means a repairable write-off or statutory write-off.

**written-off vehicle inspection** means an inspection of a repairable write-off, under procedures approved by the chief executive, to decide whether the vehicle's identity is legitimate.

**written-off vehicle inspection report** means a report from a written-off vehicle inspection that includes a decision of an approved written-off vehicle examiner that the vehicle's identity is legitimate.

**written-off vehicle inspection site** means a place where written-off vehicle inspections are performed.

**zone access registration**, for a vehicle, see section 21(3)(b).