



Queensland

Transport Operations (Road Use Management) Act 1995

Transport Operations (Road Use Management—Vehicle Standards and Safety) Regulation 2021

Current as at 20 February 2026

© State of Queensland 2026



This work is licensed under a Creative Commons Attribution 4.0 International License.



Queensland

Transport Operations (Road Use Management—Vehicle Standards and Safety) Regulation 2021

Contents

		Page
Part 1	Preliminary	
Division 1	Introduction	
1	Short title	13
2	Commencement	13
3	Application	13
Division 2	Interpretation and key concepts	
Subdivision 1	General	
4	Definitions	14
Subdivision 2	Meaning of GVM	
4A	Application of subdivision	14
4B	Way for stating maximum loaded mass	14
Subdivision 3	Other key concepts	
5	What is a light vehicle	15
6	Light vehicle standards—Act, s 148	16
7	When is a light vehicle defective	16
Part 2	Defective light vehicles	
Division 1	Offence	
8	Light vehicle must not be driven or parked on road if defective .	17
Division 2	Defect notices	
9	Issue of defect notice	18
10	Person to give owner defect notice	19
11	Compliance with defect notice	19
12	Defective vehicle labels	20
13	Completing clearance declaration for defect notice	20

Contents

14	Extension of period for complying with defect notice—authorised officer 21	
15	Extension of period for complying with defect notice—special circumstances	22
Part 3	Modifications of light vehicles and code S13 modifications of heavy buses	
Division 1	Offences	
17	When is a modification compliant	23
18	Modification, other than compliant modification, of light vehicle prohibited	24
19	Owner to ensure light vehicle not driven or parked on road with noncompliant modification	25
20	Modified exhaust system	25
Division 2	Chief executive approval of particular light vehicle modifications	
21	Application for approval to modify light vehicle	25
22	Application for approval of interstate modification of light vehicle	26
23	Deciding application	26
24	Approval or refusal of application	27
Division 3	Certifying modifications of light vehicles and code S13 modifications of heavy buses	
25	Application of division	28
26	Certifying modification	28
27	Requirements for issuing certificate of modification and attaching modification plate	29
28	Approved person only may issue certificate of modification or attach modification plate	29
Part 4	Compliance with light vehicle mass and load etc. requirements	
Division 1	Preliminary	
29	Application	30
30	Meaning of load for light vehicle	30
Division 2	Mass requirements	
31	Mass requirements—general	31
32	Compliance with mass requirements—light motor vehicle	32
33	Compliance with mass requirements—trailer	32
34	Compliance with mass requirements—light combination	32
35	Loaded mass of light vehicle without GVM or ATM	32
36	Loaded mass of light combination without GCM	33
Division 3	Load requirements	

Subdivision 1	Projection limits	
37	Application of subdivision	33
38	Measuring projection	33
39	Visibility requirements for load projecting from light vehicle	34
40	Limits on projection of load—motorbike	34
41	Limits on projection of load—light motor vehicle other than motorbike 35	
42	Limits on projection of load—light vehicle drawn by animal	36
43	Visibility requirements for projecting load not readily visible behind light motor vehicle	36
Subdivision 2	Securing loads and coupling requirements	
44	Requirements for securing load on light vehicle	37
45	Load performance standards for load on light vehicle	38
46	Compliance with coupling requirements	39
Division 4	Dimension requirements—miscellaneous vehicles	
47	Compliance with dimension requirements—miscellaneous vehicle	39
Part 5	Safe movement approvals for light vehicles	
Division 1	Preliminary	
48	Application of part	40
49	Definitions for part	40
Division 2	Purposes and effect	
50	Purpose of safe movement approval	40
51	Effect of safe movement approval	41
52	Compliance with safe movement approval	41
Division 3	Issue or grant of safe movement approval	
53	Chief executive may issue safe movement guideline	41
54	Chief executive may grant safe movement permit	42
55	Deciding to issue or grant safe movement approval	42
56	Matters for safe movement approval	42
57	Limitation about GCM	44
Division 4	Provisions relating to safe movement permits	
58	Application	44
59	Deciding application	44
60	Granting safe movement permit	45
61	Period of effect of safe movement permit	45
62	Notice of decision	46

Part 6	Vehicle safety—inspections and inspection certificates	
Division 1	Preliminary	
63	Particular references to vehicle includes component	46
64	Alternative compliance scheme—light vehicle maintenance	47
Division 2	Inspection certificates	
65	What is an inspection certificate	47
66	What is a certificate of inspection	47
67	What is a safety certificate	48
68	Earlier ending of inspection certificate	49
Division 3	Requirements for inspection certificates	
Subdivision 1	Preliminary	
69	Application of division	50
70	What is a COI vehicle	50
Subdivision 2	Registered COI vehicles	
71	Requirement for certificate of inspection	51
72	Extension of time for obtaining certificate of inspection—inspection booked using electronic system	52
73	Extension of time for obtaining certificate of inspection—special circumstances	53
Subdivision 3	Disposal of registered vehicles	
75	Requirement for inspection certificate for disposal by owner	54
76	Requirement of dealer acting in disposal	55
Division 4	Authority to approve and issue inspection certificates	
77	Approved examiner may approve inspection certificate for particular vehicles	55
78	Authorisation of approved examiner in relation to particular vehicles in special circumstances	56
79	Particular persons only to issue or approve inspection certificate	56
Division 5	Inspection certificates issued by proprietor of AIS	
Subdivision 1	Inspection of vehicles	
80	Application of subdivision	57
81	Amount charged for inspection of vehicle	57
82	Inspection of vehicle	58
83	Action after inspection—vehicle passes inspection	59
84	Issuing inspection certificate—proprietor of AIS	59
85	Approving inspection certificate—approved examiner	60
86	Action after inspection—vehicle is defective	60

Subdivision 2	Reinspection of vehicle	
87	Application of subdivision	61
88	Reinspection within 14 days—AIS where inspection report issued	61
89	Action after reinspection—vehicle passes reinspection	62
90	Action after reinspection—vehicle is defective	62
91	Inspection within 14 days—other AIS	63
92	Vehicle not returned for reinspection within 14 days after inspection report	64
Subdivision 3	Refusal of registration for inspection certificate issued in contravention of Act	
93	Application of subdivision	64
94	Request for inspection for replacement inspection certificate	65
95	Requirements relating to inspection	65
Division 6	Certificates of inspection issued by authorised officers	
96	Application of division	65
97	Fee for inspection	66
98	Authorised officer may issue certificate of inspection	66
99	Unique number for certificate of inspection given instead of issuing certificate	67
Part 7	Compliance, identification and modification plates	
100	Requirements about compliance plates or identification plates on light vehicles	67
101	Altering, defacing or removing identification plate	68
102	Altering, defacing or removing modification plate	68
103	Approval to remove identification plate or modification plate from light vehicle	69
Part 8	Provisions for applications	
104	Definitions for part	69
105	Chief executive may publish notice about applications	70
106	How applications must be made	70
107	Decision-maker may request further information	71
Part 9	General	
108	Making, possessing or using false or misleading documents	72
109	Instruments for measuring stationary noise levels—Act, s 123S	72
110	Fees	73
110A	Rounding of amounts expressed as numbers of fee units	73
111	Waiving payment of particular fee in special circumstances	73

Contents

Part 10	Transitional provisions	
Division 1	Transitional provisions for SL No. 114 of 2021	
112	Definition	74
113	Defect notices and defective vehicle labels	74
114	Chief executive approval of modification of vehicle	74
115	Certificate of modification or modification plate	75
116	Guideline or permit for safe movement of light vehicles	75
117	Existing authorisation for approved examiner to approve certificates of inspection	75
118	Certificates of inspection issued for COI vehicles before commencement 76	
119	Inspection certificates issued before commencement	76
120	Exemption from requirement for certificate of inspection for former Warroo local government area	76
121	Inspection report issued for vehicle	77
122	Refusal of registration for contravention of Act	78
123	Chief executive’s approval to remove modification plate or identification plate from light vehicle	78
124	Existing applications	78
125	Approved forms under expired regulation	79
126	Application of sch 1, ss 144A and 144B	79
127	Particular references in documents	79
Division 2	Transitional provision for Transport Legislation Amendment Regulation (No. 2) 2021	
128	Certificates of inspection issued for particular vehicles before commencement	80
Division 3	Transitional provisions for Transport and Other Legislation Amendment Regulation 2026	
129	Definitions for division	81
130	Warning signs and warning lights fitted to school bus immediately before 1 October 1999	81
131	Warning signs and lights fitted to bus under repealed standard	82
Schedule 1	Light vehicle standards (model provisions)	83
Part 1	Preliminary	
1	Sections 1 and 2 not used	84
Part 2	Interpretation and application of vehicle standards	
3	Definitions for schedule	84
4	References to vehicle, motor vehicle or trailer	93

5	When restored vehicle is built	93
6	Measurement of width of vehicles	93
7	Sections 7–14 not used	94
15	Application to vehicle or coupling complying with inconsistent ADR requirement	94
16	Non-application to vehicles subject to particular approvals	95
17	Interpretation of particular second edition ADRs	96
18	Reference to adopted standards	97
19	Compliance with particular adopted standards	97
20	Section 20 not used	98
Part 3 Australian Design Rules		
Division 1 Compliance with ADRs		
21	Second edition ADRs	98
22	Third edition ADRs	99
Division 2 Exemptions from compliance with ADRs		
23	Vehicles that are not road vehicles	101
24	Vehicles subject to particular approvals	101
24A	Vehicles subject to particular approvals etc. under Road Vehicle Standards Act 2018 (Cwlth)	102
25	Partial exemption for personally imported vehicles	102
Part 4 General safety requirements		
Division 1 All vehicles		
26	Steering	104
27	Turning ability	105
28	Ability to travel backwards and forwards	105
29	Protrusions	105
29A	Section 29A not used	105
30	Driver's view and vehicle controls	105
31	Seating	106
32	Mudguards	106
33	Horns, alarms etc.	107
34	Rear vision mirrors	108
35	Rear view mirrors—surfaces	109
36	Additional rear vision mirrors and surfaces	109
37	Automatic transmission	109
38	Diesel engines	109

Contents

39	Bonnet securing devices	110
40	Electrical wiring, components, connections and installations . . .	110
41	Television receivers and visual display units	111
42	Requirement for windscreen to be fitted	112
43	Windscreens and windows	112
44	Window tinting	113
45	Windscreen wipers and washers	115
46	Wheels and tyres—size and capacity	116
47	Pneumatic tyres for particular vehicles	116
48	Pneumatic tyres—carcass construction	116
49	Tyres—defects	117
50	Tyres—manufacturer’s rating	117
51	Retreads	118
52	Tyre tread	118
Division 2	Additional requirements for motorbikes	
53	Steering gear and handlebars	119
54	Foot rests	121
55	Chain guards	121
Part 5	Vehicle marking	
56	Engine number and vehicle identification number	121
57	White or silver band on particular vehicles	122
Part 6	Vehicle configuration and dimensions	
Division 1	Axles	
58	Axle configuration	122
59	Retractable axles	123
Division 2	Dimension requirements	
59A	Light vehicle includes load on vehicle	124
60	Meaning of rear overhang and rear overhang line	124
61	Length of single motor vehicles	125
62	Length of single trailers	126
63	Length of combinations	126
64	Rear overhang	127
65	Length—trailer drawbar	127
66	Width	128
67	Height	128
68	Ground clearance	128

Part 7	Lights and reflectors	
Division 1	Application of particular requirements	
69	Part does not apply to particular vehicles	130
70	Particular requirements apply only at night	130
Division 2	General requirements for lights	
71	Prevention of glare	130
72	Pairs of lights	130
Division 3	Headlights	
73	Headlights to be fitted to vehicles	131
74	How headlights are to be fitted	132
75	How single headlights are to be fitted	133
76	Section 76 not used	133
77	Performance of headlights	133
78	Effective range of headlights	133
79	Changing headlights from high-beam to low-beam position	134
Division 4	Parking lights	
80	Parking lights	134
Division 5	Daytime running lights	
81	Daytime running lights	136
Division 6	Tail lights	
82	Tail lights generally	137
83	Pattern of fitting tail lights	137
84	Performance of tail lights	138
85	Wiring of tail lights	138
Division 7	Number plate lights	
86	Number plate lights	139
Division 8	Clearance lights	
87	Front clearance lights	139
88	External cabin lights	140
89	Rear clearance lights	140
Division 9	Side marker lights	
90	Vehicles required to have side marker lights	141
91	Location of side marker lights	141
92	Performance of side marker lights	143
93	Side marker lights and rear clearance lights	143
Division 10	Brake lights	

Contents

94	Fitting brake lights	143
95	Performance and operation of brake lights	145
Division 11	Reversing lights	
96	Reversing lights	145
Division 12	Direction indicator lights	
97	Direction indicator lights on motor vehicles	146
98	Direction indicator lights on trailers	147
99	Location of direction indicator lights	147
100	Operation and visibility of direction indicator lights	148
Division 13	Fog lights	
101	Front fog lights	149
102	Rear fog lights	150
Division 14	Interior lights	
103	Interior lights	151
Division 15	Reflectors generally	
104	General requirements for reflectors	151
Division 16	Rear reflectors	
105	Rear reflectors	151
Division 17	Side reflectors	
106	Compulsory side reflectors on pole-type trailers	152
107	Optional side reflectors	153
Division 18	Front reflectors	
108	Compulsory front reflectors on particular trailers	153
109	Optional front reflectors	153
Division 19	Warning lights and signs on buses carrying children	
110	Application of division	154
111	Fitting of warning lights and signs	154
112	Operation and performance of warning lights	155
113	Specifications for warning signs	156
Division 20	Other lights, reflectors, rear marking plates or signals	
114	Other lights and reflectors	157
115	Rear marking plates and conspicuity markings	159
116	Signalling devices	160
117	Mechanical signalling devices	160
118	Turn signals	161
Part 8	Braking systems	

Division 1	Brake requirements for all vehicles	
119	Components of a braking system	162
120	Provision for wear	162
121	Supply of air or vacuum to brakes	162
122	Performance of braking systems	163
Division 2	Motor vehicle braking systems	
123	What braking system motor vehicle must have	165
124	Operation of brakes on motor vehicles	167
125	Air or vacuum brakes on motor vehicles	167
Division 3	Trailer braking systems	
126	What brakes a trailer must have	168
127	Operation of brakes on trailers	168
128	Air or vacuum brakes on trailers	168
Part 9	Control of emissions	
Division 1	Crank case gases and exhaust emissions	
129	Crank case gases	169
130	Visible emissions—vehicles with internal combustion engines . .	169
131	Sections 131–133 not used	169
Division 2	Exhaust systems	
134	Exhaust systems	170
Division 3	Noise emissions	
Subdivision 1	General	
135	Measurement of stationary noise levels	171
136	Meaning of certified to ADR 83/00	171
137	Silencing device for exhaust systems	172
Subdivision 2	Noise levels applying to vehicles not certified to ADR 83/00	
138	Application of subdivision	172
139	Stationary noise levels—car-type vehicles, motorbikes or motortrikes 172	
140	Stationary noise levels—other vehicles with spark ignition engines	173
141	Stationary noise levels—other vehicles with diesel engines	173
Subdivision 3	Noise levels applying to vehicles certified to ADR 83/00	
142	Stationary noise levels	174
Part 10	Alternative fuel systems	
143	LPG-powered vehicles	175
144	Vehicles powered by natural gas	176

Contents

144A	Hydrogen-powered vehicles	176
144B	Electric-powered vehicles	177
Part 11	Mechanical connections between vehicles	
145	General coupling requirements	178
146	Drawbar couplings	179
Schedule 2	Exempt areas	181
Schedule 3	Fees	183
Schedule 4	Dictionary	185

Transport Operations (Road Use Management—Vehicle Standards and Safety) Regulation 2021

Part 1 Preliminary

Division 1 Introduction

1 Short title

This regulation may be cited as the *Transport Operations (Road Use Management—Vehicle Standards and Safety) Regulation 2021*.

2 Commencement

This regulation commences on 1 September 2021.

3 Application

- (1) This regulation does not apply to a miscellaneous vehicle unless otherwise stated.
- (2) Also, this regulation applies to a light vehicle that is part of a heavy combination under the Heavy Vehicle National Law (Queensland).

[s 4]

Division 2 Interpretation and key concepts

Subdivision 1 General

4 Definitions

The dictionary in schedule 4 defines particular words used in this regulation.

Subdivision 2 Meaning of GVM

4A Application of subdivision

This subdivision prescribes the way the maximum loaded mass of a vehicle is stated for schedule 4 of the Act, definition *GVM*.

4B Way for stating maximum loaded mass

- (1) A vehicle's maximum loaded mass is the maximum loaded mass (however called) of the vehicle stated—
 - (a) if the vehicle is recorded in the RAV—in the vehicle's record in the RAV; or
 - (b) if the vehicle is not recorded in the RAV—
 - (i) on the vehicle's compliance plate; or
 - (ii) if the vehicle does not have a compliance plate or the maximum loaded mass is not stated on the compliance plate or is illegible—in writing by the vehicle's manufacturer; or
 - (c) if the maximum loaded mass is not stated in a way mentioned in paragraph (a) or (b) and the vehicle is registered in Queensland—in the vehicle's registration certificate under the Act; or

-
- (d) if the maximum loaded mass is not stated in a way mentioned in paragraph (a) or (b) and the vehicle is registered in another State—in writing by the entity responsible for registering the vehicle in that State; or
 - (e) if the maximum loaded mass is not stated in a way mentioned in paragraph (a), (b), (c) or (d)—in writing by the chief executive, or the corresponding authority under a corresponding law to the Act, having regard to the design and construction of the vehicle and any other relevant matter.
- (2) However, if a modification certificate or modification plate for a modification of the vehicle states the vehicle’s maximum loaded mass (however called), the vehicle’s maximum loaded mass is the maximum loaded mass stated in the certificate or on the plate.
- (3) In this section—
- modification certificate*** means—
- (a) for a modification of a light vehicle—a relevant certificate; or
 - (b) for a modification of a heavy vehicle—a HVNL certificate.
- modification plate*** means—
- (a) for a modification of a light vehicle—a relevant plate; or
 - (b) for a modification of a heavy vehicle—a HVNL plate.

Subdivision 3 Other key concepts

5 What is a *light vehicle*

- (1) A ***light vehicle*** is a vehicle other than a heavy vehicle.

Note—

For the meaning of *heavy vehicle*, see schedule 4 of the Act.

- (2) A reference to a *light vehicle* includes a component fitted to, or that is part of, the vehicle.

6 Light vehicle standards—Act, s 148

- (1) For section 148(a) of the Act, the following standards are prescribed as vehicle standards for light vehicles—
- (a) the light vehicle standards (model provisions);
 - (b) for a modified light vehicle—the light vehicle standards (modification);
 - (c) the light vehicle standards (safety inspection).
- (2) The standards prescribed under subsection (1) are the *light vehicle standards*.
- (3) The *light vehicle standards (model provisions)* are the provisions stated in schedule 1.
- (4) The *light vehicle standards (modification)* are the provisions of the Queensland Road Vehicle Modification Handbook that state standards for modifications of light vehicles.
- (5) The *light vehicle standards (safety inspection)* are the provisions of the Queensland Light Vehicle Inspection Manual that state standards for light vehicles.

7 When is a light vehicle defective

- (1) A light vehicle is *defective* if any of the following apply—
- (a) the vehicle does not comply with the light vehicle standards;
 - (b) a component of the vehicle—
 - (i) does not comply with the light vehicle standards; or
 - (ii) does not, or can not be reasonably relied on to, perform the intended function of the component; or

Example—

a component of the vehicle has deteriorated to the extent the component can not be reasonably relied on to perform its intended function

- (iii) prevents, or is likely to prevent, another component from complying with the light vehicle standards or performing the component's intended function;
 - (c) a modification of the vehicle is not compliant;
 - (d) the vehicle or a component of the vehicle is unsafe.
- (2) However, a light vehicle that does not comply with the light vehicle standards is not *defective* to the extent that—
- (a) the noncompliance is because of a modification of the vehicle; and
 - (b) the modification is an approved modification and complies with the approval.

Part 2 Defective light vehicles

Division 1 Offence

8 Light vehicle must not be driven or parked on road if defective

- (1) A person must not drive or park, or permit another person to drive or park, a light vehicle that is defective on a road.
- Maximum penalty—20 penalty units.
- (2) However, subsection (1) does not apply if the light vehicle is not unsafe to drive or park on a road and is being driven—
- (a) in compliance with conditions about driving the vehicle while it is defective stated in a defect notice issued for the vehicle; or
 - (b) to a place, by the most convenient and direct route, solely for the purpose of—

[s 9]

- (i) a defect of the vehicle being repaired; or
 - (ii) being inspected for an inspection certificate or certificate of modification; or
 - (c) solely to test the vehicle during an inspection for an inspection certificate.
- (3) Also, subsection (1) does not apply to a person who is not the owner of the light vehicle if the vehicle—
 - (a) is defective because a modification of the vehicle—
 - (i) is not an approved modification or certified modification; but
 - (ii) is otherwise compliant; and
 - (b) is not otherwise defective.

Division 2 Defect notices

9 Issue of defect notice

- (1) This section applies if an authorised officer reasonably believes a light vehicle is defective.
- (2) The authorised officer may issue a notice about the light vehicle being defective (a *defect notice*) and give the notice to—
 - (a) the owner of the vehicle; or
 - (b) another person who is the driver of the vehicle.
- (3) A defect notice—
 - (a) must be in the approved form; and
 - (b) must state—
 - (i) how the light vehicle is defective; and
 - (ii) the action required to be taken under the notice; and
 - (iii) the day by which the action must be taken; and

-
- (c) may impose conditions, including conditions under which the vehicle may be driven before the defects identified in the notice have been rectified.

Example of condition under which vehicle may be driven—

If the vehicle has faulty windscreen wipers, a condition that the vehicle may be driven only when it is not raining.

10 Person to give owner defect notice

- (1) This section applies if the person given a defect notice for a light vehicle is not the owner of the vehicle.
- (2) The person must give the defect notice to the owner as soon as practicable, but within 14 days, after the day the person received the notice, unless the person has a reasonable excuse.

Maximum penalty—30 penalty units.

11 Compliance with defect notice

- (1) The owner of a light vehicle must comply with a defect notice issued for the vehicle within the period mentioned in subsection (3).

Maximum penalty—30 penalty units.

- (2) However, subsection (1) does not apply to the owner of the light vehicle if, within the period mentioned in subsection (3)—
- (a) the vehicle's registration under the *Transport Operations (Road Use Management—Vehicle Registration) Regulation 2021* or a corresponding law is cancelled; or
- (b) the vehicle is disposed of to a dealer; or
- (c) the person has a reasonable excuse.
- (3) The period for complying with a defect notice is the period ending on the later of—
- (a) the day stated in the notice as the day by which the action required under the notice must be taken; or

- (b) the day an extended period for complying with the notice under section 14, 15 or 16 ends.

12 Defective vehicle labels

- (1) An authorised officer who issues a defect notice for a light vehicle may attach a defective vehicle label to the vehicle.
- (2) The defective vehicle label must be attached in a conspicuous place on the light vehicle.
- (3) A person must not alter or deface a defective vehicle label attached to a light vehicle unless the person has a reasonable excuse.

Maximum penalty—30 penalty units.

- (4) A person must not remove a defective vehicle label attached to a light vehicle unless the person—
 - (a) is an authorised officer; or
 - (b) is authorised under section 13 to sign the clearance declaration for the defect notice related to the label; or
 - (c) has a reasonable excuse.

Maximum penalty—30 penalty units.

- (5) In this section—

defective vehicle label means a label in the approved form stating a light vehicle is defective.

13 Completing clearance declaration for defect notice

- (1) If a defect notice for a light vehicle authorises the owner of the vehicle, or the owner's agent, to sign the clearance declaration for the notice, the owner or agent may sign the declaration only if the defects identified in the notice are rectified.
- (2) If a defect notice for a light vehicle requires the vehicle to be inspected by a nominated person, the nominated person may

sign the clearance declaration for the notice only if the nominated person—

- (a) has carried out the inspection required under the notice; and
 - (b) is reasonably satisfied the defects identified in the notice have been rectified; and
 - (c) if the notice required the vehicle to be inspected for compliance with the light vehicle standards—is reasonably satisfied the vehicle complies with the standards.
- (3) A person must not sign the clearance declaration for a defect notice for a light vehicle unless the person is authorised to sign the declaration under this section.

Maximum penalty—30 penalty units.

- (4) In this section—

clearance declaration, for a defect notice for a light vehicle, means the declaration included in the notice to be completed after the action required under the notice is taken.

nominated person, for a defect notice for a light vehicle, means a person nominated in the notice as a person the vehicle must be taken to for inspection after the defects identified in the notice are rectified.

14 Extension of period for complying with defect notice—authorised officer

- (1) The owner of a light vehicle, or the owner’s agent, may apply to an authorised officer to extend the period for complying with a defect notice for the vehicle under section 11.

Note—

See part 8 for provisions relevant to making an application under this section.

- (2) The application must state the reasons for seeking the extension.

- (3) The authorised officer must consider the application and decide to approve or refuse the application.
- (4) If satisfied the applicant's reasons warrant the extension, the authorised officer may decide to—
 - (a) approve the application; and
 - (b) extend the period for complying with the defect notice for a period the authorised officer considers appropriate, having regard to the applicant's reasons.
- (5) If the authorised officer extends the period for complying with the defect notice, the officer may—
 - (a) change or remove a condition of the notice; or
Example—

An authorised officer may remove a condition allowing the light vehicle to be used on a road before the action required under the notice is taken.
 - (b) impose a condition on the notice.
- (6) The authorised officer must give the owner or agent written notice of the decision.

15 Extension of period for complying with defect notice—special circumstances

- (1) If the chief executive is satisfied that special circumstances exist, the chief executive may extend the period for complying with a defect notice for a light vehicle under section 11.
Examples of special circumstances—
 - natural disasters, including floods, affecting the area in which an owner's vehicle or facilities for inspecting vehicles are located
 - flood damage to roads causing long-term road closure
- (2) The period may be extended under subsection (1) for a period the chief executive considers appropriate having regard to the special circumstances.
- (3) The chief executive may act under subsection (1) on the chief executive's own initiative or on the application of the owner of the light vehicle or the owner's agent.

-
- (4) If the chief executive extends the period for complying with the defect notice, the chief executive must—
- (a) for an extension of a defect notice for a particular light vehicle—give written notice about the extension to the owner of the vehicle or the owner’s agent; or
 - (b) otherwise—publish a notice about the extension on the department’s website.

Part 3 Modifications of light vehicles and code S13 modifications of heavy buses

Division 1 Offences

17 When is a modification *compliant*

- (1) A modification of a light vehicle is *compliant* if—
- (a) for a modification mentioned in section 21 or an interstate modification—
 - (i) the modification is an approved modification; and
 - (ii) any conditions of the approval, including a condition requiring the modification to be certified under division 3, have been complied with; or
 - (b) for another modification—
 - (i) the modification complies with the light vehicle standards (modification); and
 - (ii) for a modification required to be certified under the light vehicle standards (modification)—the modification is a certified modification.
- (2) Also, a modification of a light vehicle to fit a light or reflector, or display a warning sign, is *compliant* if the modification—
- (a) complies with a safe movement approval; or

(b) is required or permitted under the Act or another Act.

(3) In this section—

warning sign, displayed on a light vehicle, means a sign giving visible warning to other road users about the vehicle's dimensions.

18 Modification, other than compliant modification, of light vehicle prohibited

(1) A person must not modify a light vehicle in a way stated in subsection (2) unless the modification is compliant.

Maximum penalty—20 penalty units.

(2) For subsection (1), the ways are—

(a) modifying the light vehicle or a component of the vehicle in a way that—

(i) does not comply with the light vehicle standards;
or

(ii) may adversely affect the safety of the vehicle; or

(b) modifying the vehicle's chassis; or

(c) modifying the vehicle's exhaust system in a way that reduces, or is likely to reduce, the effectiveness of the system; or

(d) fitting a light or reflector to the vehicle; or

(e) displaying a warning sign on the vehicle.

(3) Subsection (1) does not apply to a person if—

(a) the light vehicle is unregistered; and

(b) when the person modified the vehicle, the person reasonably believed the vehicle would not be used on a road.

19 Owner to ensure light vehicle not driven or parked on road with noncompliant modification

- (1) The owner of a modified light vehicle must ensure the vehicle is not driven or parked on a road unless the modification of the vehicle is compliant.

Maximum penalty—60 penalty units.

- (2) Subsection (1) does not apply if a modified light vehicle is—
- (a) not unsafe to drive or park on a road; and
 - (b) being driven—
 - (i) to a place, by the most convenient and direct route, solely for the purpose of a modification of the vehicle being inspected; or
 - (ii) solely to test the vehicle during an inspection of a modification of the vehicle.

20 Modified exhaust system

A person must not drive a light motor vehicle on a road if the vehicle's exhaust system is modified in a way that reduces, or is likely to reduce, the effectiveness of the system.

Maximum penalty—20 penalty units.

Examples—

removing the diesel particulate filter or silencing device from a vehicle's exhaust system

Division 2 Chief executive approval of particular light vehicle modifications

21 Application for approval to modify light vehicle

A person may apply to the chief executive for approval to modify a light vehicle in a way that is not provided for under the light vehicle standards (modification).

Note—

See part 8 for provisions relevant to making an application under this section.

22 Application for approval of interstate modification of light vehicle

- (1) A person may apply to the chief executive for approval of an interstate modification of a light vehicle.

Note—

See part 8 for provisions relevant to making an application under this section.

- (2) The application must be accompanied by—
 - (a) a certificate for the modification issued under a corresponding law for division 3; or
 - (b) a report or other document about the modification prepared by an engineer who is appropriately qualified to prepare the report or document.

23 Deciding application

- (1) The chief executive must consider an application made under section 21 or 22 and decide to approve or refuse the application.
- (2) The chief executive may approve the application with stated conditions, including a condition that the modification must be certified under division 3.
- (3) The chief executive may approve the application if the chief executive is satisfied, having considered the proposed use of the vehicle, that the modification—
 - (a) is either—
 - (i) reasonably needed by a person who is to use the vehicle; or

Example—

for a person with a disability to access or drive the vehicle

- (ii) likely to benefit the community; and

Example—

for Queensland Rail to operate the vehicle on roads and railways

- (b) would not make the vehicle unsafe to drive or park on a road.
- (4) Also, the chief executive may approve the application if—
- (a) the application relates to a motorbike; and
 - (b) the chief executive is satisfied that the modification would not make the motorbike unsafe to drive or park on a road.

24 Approval or refusal of application

- (1) This section applies if the chief executive decides to approve or refuse an application under section 23.
- (2) If the chief executive approves the application, the chief executive must give the owner of the vehicle, or the owner's agent, a written notice stating—
 - (a) the modification is approved; and
 - (b) if the chief executive decides to impose conditions on the approval—
 - (i) the conditions; and
 - (ii) the reasons for the decision to impose the conditions; and
 - (iii) that the person may ask for the decision to impose the conditions to be reviewed.
- (3) If the chief executive refuses the application, the chief executive must give the owner of the vehicle, or the owner's agent, written notice stating the decision.
- (4) Section 65 of the Act applies to a decision to impose conditions on the approval as if a reference to an original decision in that section were a reference to the decision.

- (5) Despite subsection (4), a person may not apply to QCAT to have the decision to impose the conditions stayed.

Division 3 Certifying modifications of light vehicles and code S13 modifications of heavy buses

25 Application of division

This division applies to—

- (a) a modification of a light vehicle; or
- (b) a modification of a heavy bus identified in the light vehicle standards (modification) using the code S13 (a *code S13 modification*).

26 Certifying modification

- (1) This section applies if an approved person who inspects the modification of the vehicle is reasonably satisfied the modification—
- (a) for a modification mentioned in section 21 or an interstate modification—
 - (i) is an approved modification; and
 - (ii) complies with the approval and any conditions of the approval; or
 - (b) for another modification of a light vehicle—complies with the light vehicle standards (modification); or
 - (c) for a code S13 modification of a heavy bus—complies with the light vehicle standards (modification), to the extent the standards apply to a code S13 modification.
- (2) Immediately after finishing the inspection, the approved person must—
- (a) give the owner of the vehicle, or the owner’s agent, a certificate of modification for the modification; and

-
- (b) ensure a modification plate for the modification is attached to a conspicuous part of the vehicle.

Maximum penalty—40 penalty units.

27 Requirements for issuing certificate of modification and attaching modification plate

An approved person must not issue a certificate of modification for the modification of the vehicle, or attach a modification plate for the modification to the vehicle, unless the person—

- (a) inspects the modification in accordance with the Queensland Road Vehicle Modification Handbook; and
- (b) is reasonably satisfied the modification—
 - (i) for a modification mentioned in section 21 or an interstate modification—
 - (A) is an approved modification; and
 - (B) complies with the approval and any conditions of the approval; or
 - (ii) for another modification of a light vehicle—complies with the light vehicle standards (modification); or
 - (iii) for a code S13 modification of a heavy bus—complies with the light vehicle standards (modification), to the extent the standards apply to a code S13 modification.

Maximum penalty—50 penalty units.

28 Approved person only may issue certificate of modification or attach modification plate

- (1) A person, other than an approved person, must not issue a certificate of modification or attach a modification plate to a light vehicle or heavy bus for—
 - (a) a modification of the light vehicle; or

(b) a code S13 modification of the heavy bus.

Maximum penalty—40 penalty units.

(2) An approved person must not, unless the person is accredited to approve the type of modification, issue a certificate of modification or attach a modification plate to a light vehicle or heavy bus for—

(a) a modification of the light vehicle; or

(b) a code S13 modification of the heavy bus.

Maximum penalty—40 penalty units.

Part 4 Compliance with light vehicle mass and load etc. requirements

Division 1 Preliminary

29 Application

Despite section 3(2), this part does not apply to a light vehicle that is part of a heavy combination under the Heavy Vehicle National Law (Queensland).

Note—

For the requirements that apply to the mass, loads or couplings of a heavy combination, see the Heavy Vehicle National Law (Queensland).

30 Meaning of *load* for light vehicle

A *load* for a light vehicle includes—

(a) the vehicle's driver and all the passengers and goods in the vehicle; and

(b) all fuel, lubricants, water and readily removable equipment carried in the vehicle and required for its normal use; and

-
- (c) personal items used by the vehicle’s driver or another person necessary for the normal use of the vehicle; and
 - (d) a thing normally removed from the vehicle when the thing is not in use; and
 - (e) a thing that may fall from the vehicle when the vehicle is in motion; and
 - (f) for a pole-type trailer—a pole of the trailer.

Division 2 Mass requirements

31 Mass requirements—general

- (1) This section states the *mass requirements* applying to light vehicles.
- (2) The loaded mass for a light motor vehicle must not be more than the vehicle’s GVM.
- (3) The mass on an axle of a light vehicle must not be more than—
 - (a) if the axle is modified and a mass limit is stated for the modified axle in a certificate of modification or modification plate for the modification of the vehicle—the stated mass limit for the modified axle; or
 - (b) the mass limit for the axle set by the manufacturer of the axle.
- (4) The mass on a tyre of a light vehicle must not be more than the maximum load capacity set by the manufacturer of the tyre.
- (5) The loaded mass for a light trailer must not be more than the trailer’s ATM.
- (6) The loaded mass for a light combination must not be more than the GCM of the towing vehicle for the combination.

- (7) The mass on a coupling used between vehicles that are part of a light combination must not be more than the limit set by the manufacturer of the coupling.

32 Compliance with mass requirements—light motor vehicle

A person must not drive a light motor vehicle on a road if the vehicle or any of the vehicle's components do not comply with a mass requirement applying to the vehicle or component.

Maximum penalty—20 penalty units.

33 Compliance with mass requirements—trailer

A person must not drive a light motor vehicle towing a trailer on a road if the trailer or any of the trailer's components do not comply with a mass requirement applying to the trailer or component.

Maximum penalty—20 penalty units.

34 Compliance with mass requirements—light combination

A person must not drive a light combination on a road if the combination or any of the combination's components do not comply with a mass requirement applying to the combination or component.

Maximum penalty—20 penalty units.

35 Loaded mass of light vehicle without GVM or ATM

- (1) This section—
- (a) applies to a light vehicle, including a light vehicle that is part of a combination, that does not have—
 - (i) for a motor vehicle—a GVM; or
 - (ii) for a trailer—an ATM; but
 - (b) does not apply to a light combination.

-
- (2) A person must not drive the light vehicle on a road if the loaded mass of the vehicle is more than the mass that reasonably allows the vehicle to be driven safely having regard to the design of the vehicle.

Maximum penalty—20 penalty units.

36 Loaded mass of light combination without GCM

- (1) This section applies to a light combination that does not have a GCM.
- (2) A person must not drive the light combination on a road if the loaded mass for the combination is more than the mass that reasonably allows the combination to be driven safely having regard to the design of any vehicle that is part of the combination.

Maximum penalty—20 penalty units.

Division 3 Load requirements

Subdivision 1 Projection limits

37 Application of subdivision

This subdivision applies in addition to, and does not limit, schedule 1, part 6, division 2.

Note—

Schedule 1, part 6, division 2 states dimension requirements for light vehicles.

38 Measuring projection

For deciding whether a load projects in front of, behind or to the side of a light vehicle, a light, rear vision mirror or reflector attached to the vehicle is not taken into account when measuring the vehicle.

39 Visibility requirements for load projecting from light vehicle

The *visibility requirements* for a load projecting from a light vehicle are—

- (a) a flag that is brightly coloured red, red and yellow, or yellow and at least 450mm by 450mm is fixed to the back end of the load; and
- (b) for a light vehicle driven or parked on a road at night either—
 - (i) a light showing a clear red light to the back, visible at a distance of 200m under normal atmospheric conditions, is fixed to the back end of the load; or
 - (ii) at least 2 reflectors, capable of projecting a red reflection of light from the headlight of a vehicle following the vehicle, are fixed to the back end of the load.

Note—

See sections 41(2), 42(2) and 43 for when a load projecting from a light vehicle is required to comply with the visibility requirements.

40 Limits on projection of load—motorbike

A person must not drive or park a motorbike on a road if a load on the motorbike projects—

- (a) for a motorbike without a sidecar—
 - (i) more than 150mm in front of the motorbike’s front wheel; or
 - (ii) more than 300mm behind the motorbike’s back wheel; or
 - (iii) past the outermost part of the motorbike on either side; or
- (b) for a motorbike that has a sidecar—
 - (i) more than 600mm in front of the motorbike’s front wheel; or

-
- (ii) more than 900mm behind the motorbike’s back wheel; or
 - (iii) past the outermost part of the motorbike or sidecar on either side; or
 - (c) for a trailer being towed by a motorbike—
 - (i) more than 300mm behind the trailer; or
 - (ii) past the outermost part of the trailer on either side.
- Maximum penalty—20 penalty units.

41 Limits on projection of load—light motor vehicle other than motorbike

- (1) This section does not apply to a motorbike.
- (2) A person must not drive or park a light motor vehicle on a road if a load on the vehicle projects more than—
 - (a) for a vehicle towing a trailer—
 - (i) 1.2m in front of the vehicle’s headlights; or
 - (ii) 1.2m behind the trailer; or
 - (iii) 150mm past the outermost part of the vehicle or trailer on either side; or
 - (b) otherwise—
 - (i) 1.2m in front of the vehicle’s headlights; or
 - (ii) 1.2m behind the vehicle; or
 - (iii) 150mm past the outermost part of the vehicle on either side.

Maximum penalty—20 penalty units.

- (3) Subsection (2)(a)(ii) and (b)(ii) do not apply for a load projecting more than 1.2m behind a light motor vehicle or trailer if the visibility requirements are complied with for the load.

Note—

See section 39 for the visibility requirements for a load projecting from a light vehicle.

42 Limits on projection of load—light vehicle drawn by animal

- (1) A person must not drive or park a light vehicle drawn by an animal on a road if a load on the vehicle projects—
 - (a) in front of the animal’s head; or
 - (b) for a pole-type trailer—past the back end of the pole of the trailer; or
 - (c) for another type of vehicle—more than 1m behind the vehicle; or
 - (d) more than 300mm past the outermost part of the vehicle on either side.

Maximum penalty—20 penalty units.

- (2) Subsection (1)(b) and (c) do not apply for a load projecting past the back end of the pole for a pole-type trailer or more than 1m behind a light vehicle drawn by an animal if the visibility requirements are complied with for the load.

Note—

See section 39 for the visibility requirements for a load projecting from a light vehicle.

43 Visibility requirements for projecting load not readily visible behind light motor vehicle

The driver of a light motor vehicle must comply with the visibility requirements for a load on the vehicle, or on a trailer being towed by the vehicle, if the load projects in a way that would not be readily visible to a person following immediately behind the vehicle.

Maximum penalty—20 penalty units.

Note—

See section 39 for the visibility requirements for a load projecting from a light vehicle.

Subdivision 2 Securing loads and coupling requirements

44 Requirements for securing load on light vehicle

- (1) A person who drives or parks a light vehicle on a road must ensure a load on the vehicle—
 - (a) is not placed in a way that makes the vehicle unstable or unsafe; and
 - (b) is secured in a way that makes it unlikely to fall or be dislodged from the vehicle; and
 - (c) is restrained using an appropriate method.

Maximum penalty—20 penalty units.

- (2) In a proceeding for an offence against subsection (1)—
 - (a) evidence that a load on a light vehicle was not placed, secured or restrained in a way that met the load performance standards is evidence of a contravention of subsection (1); and
 - (b) evidence that a load, or part of a load, fell from a light vehicle is evidence that the load was not properly secured; and
 - (c) a court must presume a document purporting to be the load restraint guide for light vehicles is the load restraint guide for light vehicles until the contrary is proved.

Note—

The load restraint guide for light vehicles contains examples of appropriate methods for loading vehicles. The guide is available on the National Transport Commission's website.

- (3) In this section—

load performance standards see section 45.

load restraint guide for light vehicles means the document titled ‘Load restraint guide for light vehicles’ published by the National Transport Commission.

45 Load performance standards for load on light vehicle

- (1) This section states the *load performance standards* for a load on a light vehicle.
- (2) A load on a light vehicle must be restrained in a way that—
 - (a) prevents the load from moving in relation to the vehicle if the loaded vehicle is subjected to any of the following, separately—
 - (i) 0.8g deceleration in a forward direction;
 - (ii) 0.5g deceleration in a backward direction;
 - (iii) 0.5g acceleration in a lateral direction; and
 - (b) if friction or limited vertical displacement is relied on to comply with paragraph (a)—prevents the load from moving in relation to the vehicle if the loaded vehicle is subjected to 0.2g acceleration in a vertical direction relative to the load; and
 - (c) at a minimum, is capable of withstanding the forces that would result in the circumstances mentioned in paragraphs (a) and (b).
- (3) Despite subsection (2), a load on a light vehicle may move in relation to the vehicle if—
 - (a) the vehicle’s stability and weight distribution are not adversely affected by the movement; and
 - (b) the load does not become dislodged from the vehicle.

Examples—

- a load contained within the sides or enclosure of a light vehicle restrained from moving horizontally may move vertically
- a load of very light objects, or a loose bulk load, contained within an enclosed part of a light vehicle may move horizontally and vertically

-
- liquid in a bulk load contained in an enclosed tank on a light vehicle may move within the tank

46 Compliance with coupling requirements

A person who drives or parks a light combination on a road must ensure—

- (a) the trailer that is part of the combination is securely coupled to the vehicle in front of the trailer; and
- (b) the components of the coupling used between the vehicles that are part of the combination are compatible with and properly connected to each other.

Maximum penalty—20 penalty units.

Division 4 Dimension requirements—miscellaneous vehicles

47 Compliance with dimension requirements—miscellaneous vehicle

A person must not drive or park a light vehicle that is a miscellaneous vehicle on a road unless the vehicle complies with schedule 1, sections 61 to 67.

Maximum penalty—20 penalty units.

Note—

Schedule 1, sections 61 to 67 state requirements about the dimensions of light vehicles.

Part 5 **Safe movement approvals for light vehicles**

Division 1 **Preliminary**

48 **Application of part**

For section 3(1), this part applies to a light vehicle, including a miscellaneous vehicle.

49 **Definitions for part**

In this part—

exempted provision, for a safe movement approval, means a provision of this regulation that—

- (a) imposes a requirement relating to the use of a light vehicle on a road; and
- (b) is stated in the approval as a provision that a light vehicle or a person driving a light vehicle is exempted from while the vehicle is driven in compliance with the approval.

safe movement approval means—

- (a) a safe movement guideline; or
- (b) a safe movement permit.

Division 2 **Purposes and effect**

50 **Purpose of safe movement approval**

The purpose of a safe movement approval is to provide for conditions under which light vehicles may be driven safely on a road in circumstances that would otherwise contravene a stated provision of this regulation.

51 Effect of safe movement approval

- (1) This section applies if a light vehicle is driven or parked on a road under, or purportedly under, the authority of a safe movement approval.
- (2) However, this section stops applying—
 - (a) if the driver of the light vehicle contravenes the safe movement approval; and
 - (b) while the driver’s contravention continues.
- (3) An exempted provision for the safe movement approval does not apply in relation to the light vehicle or the driver of the vehicle.

52 Compliance with safe movement approval

- (1) A person who drives a light vehicle on a road under, or purportedly under, the authority of a safe movement approval must not contravene the approval.

Maximum penalty—20 penalty units.

- (2) If, because of the operation of section 51(2), a person commits an offence against another provision of this regulation, the person—
 - (a) may be charged with an offence against either subsection (1) or the other provision; and
 - (b) must not be charged with both offences.

Division 3 Issue or grant of safe movement approval

53 Chief executive may issue safe movement guideline

- (1) The chief executive may issue a guideline (a *safe movement guideline*) for a type of light vehicle.
- (2) A safe movement guideline must be published on the department’s website.

- (3) A safe movement guideline takes effect—
 - (a) when the guideline is published on the department’s website; or
 - (b) on a later day stated in the guideline.

54 Chief executive may grant safe movement permit

The chief executive may grant a permit (a *safe movement permit*) for 1 or more light vehicles to a person.

55 Deciding to issue or grant safe movement approval

- (1) In deciding whether to issue a safe movement guideline or grant a safe movement permit, the chief executive must consider the following matters for a light vehicle the guideline or permit is to apply to—
 - (a) the particular circumstances of the vehicle being driven on a road;
 - (b) whether, and under what conditions, the vehicle may be driven safely on a road in the circumstances;
 - (c) whether, in the circumstances, driving the vehicle on a road in compliance with the proposed conditions would be at least as safe as driving the vehicle in compliance with the proposed exempted provision.
- (2) Subsection (1) does not limit the matters the chief executive may consider.

56 Matters for safe movement approval

- (1) A safe movement approval must state—
 - (a) for a safe movement guideline—the type of light vehicle it applies to; and
 - (b) for a safe movement permit—the particular light vehicle or light vehicles it applies to; and

-
- (c) the conditions for driving a light vehicle on a road under the authority of the approval; and
 - (d) the exempted provision for the approval.
- (2) A condition of a safe movement approval may provide for the following matters for a light vehicle to which the approval applies—
- (a) the roads on which the vehicle may or may not be driven;
 - (b) the maximum speed at which the vehicle may be driven;
 - (c) any modification required to, or that may, be made to the vehicle before it is driven;
- Example—*
- Extra lighting may be required to be added to the side of a vehicle carrying a wide load.
- (d) when the vehicle may, or may not, be driven;
 - (e) the signs or warning devices to be displayed on the vehicle;
 - (f) the maximum dimensions allowed for the vehicle and any load on the vehicle;
 - (g) the maximum mass allowed for the vehicle and any load on the vehicle;
 - (h) requirements for—
 - (i) escort vehicles and escort vehicle drivers; or
 - (ii) pilot vehicles and pilot vehicle drivers;
 - (i) other matters relevant to the safe use of the vehicle on the roads.
- (3) A map may be included in safe movement approval to show the roads on which a light vehicle may or may not be driven under the approval.
- (4) For subsection (3), a map may be included in a safe movement guideline by being linked electronically to the guideline.

57 Limitation about GCM

A safe movement approval must not allow a light combination to be more than the GCM of the towing vehicle of the combination.

Division 4 Provisions relating to safe movement permits

58 Application

A person may apply to the chief executive for a safe movement permit for 1 or more light vehicles.

Note—

See part 8 for provisions relevant to making an application under this section.

59 Deciding application

- (1) The chief executive must consider an application for a safe movement permit made under section 58 and decide—
 - (a) to grant the permit; or
 - (b) to refuse the application.
- (2) If the chief executive decides to grant the safe movement permit, the chief executive must also decide the conditions of the permit that apply to a light vehicle being driven or parked on a road under the authority of the permit.
- (3) Without limiting subsection (2), a condition may require a person driving a light vehicle under the safe movement permit to carry the permit, or a copy of the permit, to be produced for immediate inspection if an authorised officer asks to see it.
- (4) The chief executive must make a decision under this section within 28 days after—
 - (a) the day the chief executive receives the application; or

-
- (b) if the chief executive gives the applicant a notice under section 107 asking for further information to decide the application—the day the notice is given to the applicant.

60 Granting safe movement permit

- (1) As soon as practicable after deciding to grant a safe movement permit to a person, the chief executive must give the permit to the person.
- (2) In addition to the matters mentioned in section 56(1), the safe movement permit must state—
 - (a) for each light vehicle the permit is granted for—
 - (i) the vehicle’s registration number; or
 - (ii) the vehicle’s VIN or other unique identifying number; or
 - (iii) the vehicle’s chassis number; or
 - (iv) if the vehicle does not have the numbers mentioned in subparagraph (i), (ii) or (iii)—other information identifying the vehicle; and
 - (b) the person’s name and address; and
 - (c) the period for which the permit is issued.

61 Period of effect of safe movement permit

- (1) A safe movement permit has effect for the period stated in the permit.
- (2) However, a safe movement permit stops having effect for a light vehicle stated in the permit before the end of the stated period if—
 - (a) the vehicle is disposed of; or
 - (b) the registration of the vehicle is transferred to another person.
- (3) If a safe movement permit issued for more than 1 light vehicle stops having effect in relation to 1 of the light vehicles under

[s 62]

subsection (2), the permit continues having effect under subsection (1) for other vehicles stated in the permit.

62 Notice of decision

- (1) This section applies to a decision of the chief executive—
 - (a) about the conditions of a safe movement permit under section 59(2); or
 - (b) to refuse an application for a safe movement permit.
- (2) The chief executive must give written notice of the decision to the applicant as soon as practicable after making the decision.
- (3) The notice must state—
 - (a) the reasons for the decision; and
 - (b) that the person may ask for the decision to be reviewed.
- (4) Section 65 of the Act applies to the decision as if a reference to an original decision in that section were a reference to the decision.
- (5) However, despite subsection (4), a person may not apply to QCAT to have the decision to impose the conditions stayed.
- (6) Section 65A of the Act applies to a decision to refuse the application as if a reference to a reviewed decision in that section were a reference to the decision.

Part 6 Vehicle safety—inspections and inspection certificates

Division 1 Preliminary

63 Particular references to vehicle includes component

In a provision of this part that applies to a heavy vehicle, a reference to a vehicle includes a component fitted to, or that is part of, the heavy vehicle.

64 Alternative compliance scheme—light vehicle maintenance

For section 15(1) of the Act, sections 71 and 75 are prescribed for a light vehicle mentioned in that section of the Act for the purpose of ensuring the light vehicle is not defective.

Division 2 Inspection certificates

65 What is an *inspection certificate*

A certificate of inspection and a safety certificate are each an *inspection certificate*.

66 What is a *certificate of inspection*

- (1) A *certificate of inspection* is a certificate in the approved form issued for a vehicle.
- (2) The *COI term* for a certificate of inspection issued for a vehicle is the following period, including the day on which the certificate takes effect—
 - (a) for a heavy primary production vehicle—2 years;
 - (b) otherwise—1 year.
- (3) A certificate of inspection for a vehicle—
 - (a) takes effect—
 - (i) for a certificate issued not more than 2 months before the previous certificate for the vehicle expires—on the day after the previous certificate expires; or
 - (ii) for a certificate issued during the COI period for the previous certificate for the vehicle—on the day after the previous certificate expired; or
 - (iii) otherwise—when the certificate is issued; and
 - (b) continues in effect until the end of the COI term for a certificate issued for the vehicle.

[s 67]

- (4) For subsection (3)(a)(ii), the *COI period* for a previous certificate for a vehicle is the following period for the vehicle, starting on the day after the previous certificate expired—
 - (a) for a heavy primary production vehicle—2 years;
 - (b) otherwise—1 year.
- (5) Also, for a new vehicle for subsection (3)(a)(ii), a previous certificate is taken to have—
 - (a) been issued for the vehicle on the day the vehicle was first registered; and
 - (b) expired on the day before the first anniversary of the vehicle’s registration.
- (6) In this section—

heavy primary production vehicle means a vehicle mentioned in the *Transport Operations (Road Use Management—Vehicle Registration) Regulation 2021*, section 241.

previous certificate, in relation to a certificate of inspection issued (the *current certificate*) for a vehicle, means the most recent certificate of inspection issued for the vehicle before the current certificate.

67 What is a *safety certificate*

- (1) A *safety certificate* is a certificate in the approved form issued for a vehicle.
- (2) A safety certificate for a vehicle being disposed of by a dealer takes effect when the certificate is issued and continues in effect—
 - (a) for a period of 3 months, including the day on which the certificate is issued; or
 - (b) until the vehicle is driven 1,000km after the certificate is issued; or
 - (c) until the vehicle is disposed of other than to another dealer.

-
- (3) A safety certificate for another vehicle takes effect when the certificate is issued and continues in effect—
 - (a) for a period of 2 months, including the day on which the certificate is issued; or
 - (b) until the vehicle is driven 2,000km after the certificate is issued; or
 - (c) until the vehicle is disposed of other than to a dealer.

68 Earlier ending of inspection certificate

- (1) This section applies despite another provision of this division.
- (2) An inspection certificate issued for a vehicle stops having effect when—
 - (a) the vehicle's registration under the *Transport Operations (Road Use Management—Vehicle Registration) Regulation 2021* or a corresponding law is cancelled; or
 - (b) an unapproved modification is made to the vehicle; or
 - (c) the condition of the vehicle changes significantly other than because the vehicle has been modified.
- (3) In this section—

unapproved modification, of a vehicle, means a modification of the vehicle that is not—

- (a) a compliant modification of a light vehicle; or
- (b) a code S13 modification of a heavy bus that is a certified modification; or
- (c) a modification of a heavy vehicle, other than modification mentioned in paragraph (b), approved under the Heavy Vehicle National Law (Queensland), section 86 or 87 or a corresponding law.

Division 3 Requirements for inspection certificates

Subdivision 1 Preliminary

69 Application of division

This division does not apply to—

- (a) a trailer that has an ATM of 0.75t or less; or
- (b) a dump truck for which concessional registration is granted under the *Transport Operations (Road Use Management—Vehicle Registration) Regulation 2021* as a motor vehicle mentioned in schedule 5 of that regulation; or
- (c) a mobile crane; or
- (d) a straddle truck; or
- (e) a tractor; or
- (f) a vehicle that, under the *Transport Operations (Road Use Management—Vehicle Registration) Regulation 2021*, is—
 - (i) an agricultural implement; or
 - (ii) an agricultural machine; or
 - (iii) mobile machinery.

70 What is a *COI vehicle*

- (1) Each of the following vehicles is a *COI vehicle*—
 - (a) a heavy vehicle;
 - (b) a light vehicle that is—
 - (i) a booked hire vehicle, limousine or taxi; or
 - (ii) another vehicle used to provide a public passenger service; or

-
- (iii) an authorised tow truck for an operator accreditation under the *Tow Truck Act 2023*.
- (2) However, a concessionally registered ambulance vehicle is not a **COI vehicle**.
- (3) Also, a vehicle used to provide a public passenger service (other than a booked hire vehicle, limousine or taxi) is not a **COI vehicle** if the vehicle—
- (a) is used only to provide a community transport service or courtesy transport service, or both; and
 - (b) is not used by a school to provide a service mentioned in paragraph (a) to carry students attending the school; and
 - (c) is built to carry 9 or fewer seated adults.
- (4) In this section—
- community transport service** see the *Transport Operations (Passenger Transport) Act 1994*, schedule 3.
- concessionally registered ambulance vehicle** means a vehicle that is—
- (a) an ambulance vehicle under the *Transport Operations (Road Use Management—Vehicle Registration) Regulation 2021*; and
 - (b) concessionally registered under that regulation.
- courtesy transport service** see the *Transport Operations (Passenger Transport) Act 1994*, schedule 3.

Subdivision 2 Registered COI vehicles

71 Requirement for certificate of inspection

- (1) The owner of a registered COI vehicle must ensure a certificate of inspection is in effect for the vehicle.
- Maximum penalty—60 penalty units.
- (2) However, subsection (1) does not apply to—

[s 72]

- (a) a vehicle for which an extension of time for obtaining a certificate of inspection is operating under section 72, 73 or 74; or
- (b) a new vehicle during the year after it is first registered; or
- (c) a special interest vehicle under the *Transport Operations (Road Use Management—Vehicle Registration) Regulation 2021* for which concessional registration is granted under that regulation; or
- (d) a light vehicle operating under an alternative compliance scheme approved by the chief executive; or
- (e) a heavy vehicle identified in a maintenance management system for a maintenance management accreditation as a vehicle being operated in accordance with the system; or
- (f) a vehicle being used only in an exempt area for a COI vehicle.

72 Extension of time for obtaining certificate of inspection—inspection booked using electronic system

- (1) This section applies if—
 - (a) to comply with section 71, a person is required to obtain a certificate of inspection for a COI vehicle before a particular day (the *compliance day*), including, for example, because a previous certificate of inspection issued for the vehicle is due to expire; and
 - (b) the electronic system does not allow the person to book an inspection of the vehicle for the issue of a certificate of inspection at a place that is reasonably convenient for the person before the compliance day; and
 - (c) using the electronic system, the person books an inspection within 2 months after the compliance day.
- (2) The time for obtaining a certificate of inspection for the COI vehicle is extended until—

-
- (a) the inspection is carried out; or
 - (b) the person cancels the appointment for the inspection; or
 - (c) the inspection is not carried out and the time for the appointment passes.

73 Extension of time for obtaining certificate of inspection—special circumstances

- (1) If the chief executive is satisfied that special circumstances exist, the chief executive may extend the time for obtaining a certificate of inspection for a COI vehicle.

Examples of special circumstances—

- natural disasters, including floods, affecting the area in which an owner’s vehicle or inspection facilities are located
 - flood damage to roads causing long-term road closure
- (2) The time may be extended under subsection (1) for a period the chief executive considers appropriate having regard to the special circumstances.
 - (3) The chief executive may act under subsection (1) on the chief executive’s own initiative or on the application of the owner of the COI vehicle or the owner’s agent.
 - (4) If the chief executive extends the time for obtaining a certificate of inspection, the chief executive must—
 - (a) for an extension of time for a particular COI vehicle—give written notice about the extension to the owner of the vehicle or the owner’s agent; or
 - (b) otherwise—publish a notice about the extension on the department’s website.

Subdivision 3 Disposal of registered vehicles

75 Requirement for inspection certificate for disposal by owner

- (1) The owner of a registered vehicle must not dispose of the vehicle to another person (the *acquirer*) unless—
 - (a) an inspection certificate is in effect for the vehicle; and
 - (b) the owner gives the acquirer—
 - (i) for an inspection certificate issued manually—the original and duplicate of the certificate; or
 - (ii) otherwise—a copy of the certificate or the unique number for the certificate.

Maximum penalty—60 penalty units.

- (2) However, subsection (1) does not apply to—
 - (a) a vehicle disposed of to a dealer; or
 - (b) the owner of a vehicle who lives in an exempt area for the vehicle and disposes of the vehicle in that area; or
 - (c) a light vehicle—
 - (i) being maintained under an alternative compliance scheme approved by the chief executive; and
 - (ii) that, after the disposal, will continue to be maintained under an alternative compliance scheme approved by the chief executive; or
 - (d) a heavy vehicle—
 - (i) identified in, and maintained under, a maintenance management system for a maintenance management accreditation; and
 - (ii) that, after the disposal, will continue to be maintained under a maintenance management system for a maintenance management accreditation.

76 Requirement of dealer acting in disposal

- (1) A dealer must not act for the owner of a registered vehicle to dispose of the vehicle unless the dealer ensures the owner complies with section 75, whether or not the owner complies through the dealer.

Maximum penalty—60 penalty units.

- (2) However, subsection (1) does not apply if the owner lives in an exempt area for the registered vehicle and the vehicle is being disposed of in that area.

Division 4 Authority to approve and issue inspection certificates

77 Approved examiner may approve inspection certificate for particular vehicles

- (1) An approved examiner may approve an inspection certificate for—
- (a) a registered vehicle that is—
 - (i) a motor vehicle with a GVM of 16t or less; or
 - (ii) a trailer with an ATM of 10t or less; or
 - (iii) if the approved examiner is authorised, by notice given under section 78, to approve certificates of inspection for a type of vehicle—a vehicle of the type stated in the notice; or
 - (b) a vehicle that is not registered.
- (2) Also, an approved examiner may approve a certificate of inspection for a vehicle if—
- (a) the vehicle is a registered vehicle that is—
 - (i) a motor vehicle with a GVM of more than 16t; or
 - (ii) a trailer with an ATM of more than 10t; and
 - (b) the vehicle has a garage address in an exempt area; and

[s 78]

(c) the approved examiner inspects the vehicle in an exempt area.

(3) In this section—

garage address see the *Transport Operations (Road Use Management—Vehicle Registration) Regulation 2021*, section 5.

78 Authorisation of approved examiner in relation to particular vehicles in special circumstances

(1) This section applies if the chief executive is satisfied special circumstances exist to authorise an approved examiner to approve certificates of inspection for the following types of registered vehicle—

(a) a motor vehicle with a GVM of more than 16t;

(b) a trailer with an ATM of more than 10t.

Examples of special circumstances—

- natural disasters, including floods, affecting—
 - (a) access to places where vehicle inspections are carried out; or
 - (b) the availability of vehicle inspections because of the diversion of resources or loss of inspection capability
- the availability of authorised officers to inspect vehicles in remote areas

(2) The chief executive may, by written notice given to the approved examiner, authorise the approved examiner to approve certificates of inspection for registered vehicles of the type.

(3) The notice must state that the authorisation is for a period, stated in the notice, the chief executive considers appropriate having regard to the special circumstances.

79 Particular persons only to issue or approve inspection certificate

(1) A person must not—

-
- (a) issue, or purportedly issue, a certificate of inspection for a vehicle unless—
 - (i) the person is an authorised officer, other than a police officer; or
 - (ii) the person is a proprietor of an AIS and issues the certificate under section 84; or
 - (b) issue, or purportedly issue, a safety certificate for a vehicle unless the person is a proprietor of an AIS and issues the certificate under section 84.

Maximum penalty—30 penalty units.

- (2) A person must not approve, or purportedly approve, an inspection certificate for a vehicle unless the person is an approved examiner and approves the certificate under section 85.

Maximum penalty—30 penalty units.

Division 5 Inspection certificates issued by proprietor of AIS

Subdivision 1 Inspection of vehicles

80 Application of subdivision

This subdivision applies if the owner of a vehicle, or the owner’s agent, asks the proprietor of an AIS to issue an inspection certificate for the vehicle.

81 Amount charged for inspection of vehicle

- (1) The proprietor of an AIS may charge the owner of the vehicle, or the owner’s agent, an amount to inspect the vehicle for the issue of an inspection certificate.
- (2) The amount charged must not be more than the fee stated in schedule 3 for the inspection.

[s 82]

- (3) Subsection (2) does not limit the amounts the proprietor may charge—
- (a) for a mobile AIS—for travelling to a place to inspect the vehicle; or
 - (b) for replacing minor parts required to be removed to carry out the inspection if best practice is to replace the parts after they are removed.

Examples of minor parts that best practice is to replace—

split pins, lock nuts

- (4) In this section—

mobile AIS see the *Transport Operations (Road Use Management—Accreditation and Other Provisions) Regulation 2015*, schedule 7.

82 Inspection of vehicle

- (1) Before inspecting the vehicle, the approved examiner who inspects the vehicle must locate on the vehicle and record for the inspection—
- (a) for a motor vehicle manufactured before 1 January 1989—the vehicle’s chassis number and engine number; or
 - (b) for a motor vehicle manufactured on or after 1 January 1989—the vehicle’s VIN; or
 - (c) for a vehicle other than a motor vehicle—another unique identification number assigned to the vehicle.

Maximum penalty—20 penalty units.

- (2) The approved examiner must inspect the vehicle—
- (a) thoroughly; and
 - (b) in accordance with—
 - (i) for a light vehicle—the Queensland Light Vehicle Inspection Manual; or

-
- (ii) for a heavy vehicle—the National Heavy Vehicle Inspection Manual.
- (3) If the vehicle is a modified heavy vehicle, other than a heavy bus with code S13 modification, the approved examiner must, when inspecting the vehicle—
- (a) sight an HVNL certificate for the modification; or
 - (b) locate an HVNL plate for the modification fitted or affixed to the vehicle.

83 Action after inspection—vehicle passes inspection

- (1) This section applies if the approved examiner who inspects the vehicle under section 82 is reasonably satisfied the vehicle is not defective.
- (2) Immediately after the inspection is finished, the proprietor of the AIS must give the owner of the vehicle, or the owner’s agent, an inspection certificate for the vehicle issued under section 84.

Maximum penalty—30 penalty units.

84 Issuing inspection certificate—proprietor of AIS

- (1) The proprietor of the AIS issues an inspection certificate for the vehicle by—
- (a) for a certificate issued electronically—approving the certificate using the electronic system; or
 - (b) for a certificate issued manually—signing the certificate.
- (2) Before issuing an inspection certificate for a vehicle, the proprietor of the AIS for the inspection must ensure the certificate is—
- (a) completed correctly; and
 - (b) for a certificate issued manually—
 - (i) completed legibly; and

- (ii) not altered; and
- (c) approved under section 85 by the approved examiner who inspected the vehicle.

Maximum penalty—30 penalty units.

85 Approving inspection certificate—approved examiner

- (1) The approved examiner approves an inspection certificate for the vehicle by—
 - (a) for a certificate issued electronically—using the electronic system to submit the certificate to the proprietor of the AIS; or
 - (b) for a certificate issued manually—signing the certificate.
- (2) Before approving an inspection certificate for the vehicle, the approved examiner must ensure—
 - (a) the certificate is completed correctly; and
 - (b) for a certificate issued manually—
 - (i) the certificate is completed legibly; and
 - (ii) no entry in the certificate has been altered.

Maximum penalty—30 penalty units.

- (3) The approved examiner must not approve an inspection certificate for the vehicle unless the examiner—
 - (a) inspected the vehicle under section 82; and
 - (b) is reasonably satisfied the vehicle is not defective.

Maximum penalty—50 penalty units.

86 Action after inspection—vehicle is defective

- (1) This section applies if the approved examiner who inspects a vehicle under section 82 is reasonably satisfied the vehicle is defective.

-
- (2) Immediately after finishing the inspection, the approved examiner must—
- (a) issue a report, in the approved form, stating how the vehicle is defective (*inspection report*); and
 - (b) give a copy of the inspection report to the owner of the vehicle, or the owner’s agent.

Maximum penalty—30 penalty units.

Subdivision 2 Reinspection of vehicle

87 Application of subdivision

This subdivision applies in relation to a vehicle for which an inspection report was issued.

88 Reinspection within 14 days—AIS where inspection report issued

- (1) This section applies if, within 14 days after the day the inspection report was issued—
- (a) the owner of the vehicle, or the owner’s agent, asks the proprietor of the AIS where the inspection report was issued to arrange for the vehicle to be reinspected; and
 - (b) the vehicle is returned to the AIS for reinspection; and
 - (c) the vehicle is reinspected at the AIS.

Note—

See section 91 for the requirements applying if the proprietor of the AIS is unable to comply with subsection (2) within 14 days after the day the inspection report was issued.

- (2) The proprietor of the AIS must arrange for the vehicle to be reinspected by—
- (a) the approved examiner who issued the inspection report;
or

[s 89]

- (b) if the approved examiner is absent from the AIS when the vehicle is returned for reinspection—another approved examiner who—
 - (i) works at the AIS; and
 - (ii) is accredited to inspect vehicles of the type returned for reinspection.

Maximum penalty—30 penalty units.

- (3) The approved examiner who reinspects the vehicle must inspect the vehicle to the extent necessary to decide whether the defects stated in the inspection report have been satisfactorily rectified.

89 Action after reinspection—vehicle passes reinspection

- (1) This section applies if the approved examiner who reinspects a vehicle under section 88 is reasonably satisfied—
 - (a) the defects stated in the inspection report for the vehicle have been rectified; and
 - (b) the vehicle is not otherwise defective.
- (2) Immediately after the reinspection is finished, the proprietor of the AIS must give the owner of the vehicle, or the owner's agent, an inspection certificate for the vehicle.

Maximum penalty—30 penalty units.

- (3) Sections 84 and 85 apply for issuing the inspection certificate as if the reference in section 85(3) to the vehicle being inspected under section 82 were a reference to the vehicle being reinspected under section 88.

90 Action after reinspection—vehicle is defective

- (1) This section applies if the approved examiner who reinspects a vehicle under section 88 is reasonably satisfied—
 - (a) 1 or more of the defects stated in the inspection report have not been satisfactorily rectified; or

-
- (b) the vehicle is otherwise defective.
 - (2) Immediately after finishing the reinspection, the approved examiner must—
 - (a) issue a further inspection report for the vehicle; and
 - (b) give a copy of the inspection report to the owner of vehicle or the owner’s agent; and
 - (c) if the inspection report mentioned in subsection (1)(a) was issued manually—cancel the inspection certificate relating to the report by writing the word ‘cancelled’ on the certificate.

Maximum penalty—30 penalty units.

91 Inspection within 14 days—other AIS

- (1) This section applies if, within 14 days after the inspection report was issued—
 - (a) the owner of the vehicle, or the owner’s agent, asks the proprietor of the AIS where the inspection report was issued to arrange for the vehicle to be reinspected; and
 - (b) the proprietor is unable to comply with section 88(2).
- (2) The proprietor must—
 - (a) arrange with the proprietor of another AIS for the vehicle to be inspected under subdivision 1 at the other AIS—
 - (i) at another time convenient to the owner or agent, but within 14 days after the day the inspection report was issued; and
 - (ii) at no further cost to the owner or agent; or
 - (b) refund the amount paid for the inspection under section 81 to the owner or agent.

Maximum penalty—30 penalty units.

[s 92]

- (3) Subdivision 1 applies for the inspection as if the owner or agent asked the proprietor of the other AIS to issue an inspection certificate for the vehicle.

92 Vehicle not returned for reinspection within 14 days after inspection report

- (1) This section applies if—
 - (a) the vehicle is not returned to the AIS where the inspection report was issued for reinspection within 14 days after the day of the report’s issue; and
 - (b) the inspection report was issued manually.
- (2) The proprietor of the AIS where the inspection report was issued must cancel the inspection certificate relating to the report by writing the word ‘cancelled’ on the certificate.

Maximum penalty—30 penalty units.

Subdivision 3 Refusal of registration for inspection certificate issued in contravention of Act

93 Application of subdivision

This subdivision applies if—

- (a) the proprietor of an AIS issues an inspection certificate for a vehicle; and
- (b) an application for registration of the vehicle is refused under the *Transport Operations (Road Use Management—Vehicle Registration) Regulation 2021*, section 22(1)(f).

94 Request for inspection for replacement inspection certificate

Within 14 days after the day the application is refused, the person issued the inspection certificate, or the person's agent, may ask the proprietor of the AIS where the certificate was issued to again inspect the vehicle for an inspection certificate (*a replacement inspection certificate*).

95 Requirements relating to inspection

- (1) The proprietor of the AIS must ensure the vehicle is inspected for the replacement inspection certificate—
 - (a) within 7 days after the person asks for the inspection under section 94; and
 - (b) at a time convenient to the person.

Maximum penalty—20 penalty units.

- (2) Subdivision 1 applies for the inspection.
- (3) Despite section 81, the proprietor must not charge the person a fee for—
 - (a) inspecting the vehicle; or
 - (b) issuing a replacement inspection certificate.

Maximum penalty—20 penalty units.

Division 6 Certificates of inspection issued by authorised officers

96 Application of division

This division applies if the owner of a vehicle, or the owner's agent, asks for a certificate of inspection to be issued for a vehicle by an authorised officer.

97 Fee for inspection

The fee stated in schedule 3 is payable for an inspection of a vehicle for the issue of a certificate of inspection.

98 Authorised officer may issue certificate of inspection

- (1) An authorised officer, other than a police officer, may issue a certificate of inspection for a vehicle if the authorised officer—
 - (a) inspected the vehicle and is reasonably satisfied the vehicle is not defective; or
 - (b) reasonably believes—
 - (i) the vehicle was inspected by another person, who is appropriately qualified to inspect the vehicle, and
 - (ii) the other person found the vehicle to not be defective.

Note—

See section 9 for the action an authorised officer may take if the officer reasonably believes a light vehicle is defective. See also the Heavy Vehicle National Law (Queensland), section 526 in relation to vehicle defect notices for heavy vehicles.

- (2) Subject to section 99, the authorised officer must, immediately after issuing a certificate of inspection for a vehicle, give the certificate to the owner of the vehicle or the owner's agent.
- (3) If the authorised officer inspects the vehicle, the inspection must be carried out in a way that is consistent with—
 - (a) for a light vehicle—the Queensland Light Vehicle Inspection Manual; or
 - (b) for a heavy vehicle—the National Heavy Vehicle Inspection Manual.

99 Unique number for certificate of inspection given instead of issuing certificate

- (1) For section 98(2), an authorised officer is taken to have issued a certificate of inspection for a vehicle and given the certificate to the owner of the vehicle or the owner’s agent if—
 - (a) the authorised officer gives the owner or agent the unique number for the certificate; or
 - (b) the owner or agent may access the unique number for the certificate using the department’s website.
- (2) A certificate of inspection under subsection (1) is taken to have been issued when a record about the issue of the certificate is made in the COI database.
- (3) The chief executive must give the owner of a vehicle, or the owner’s agent, a certificate of inspection for the vehicle if the owner or agent—
 - (a) gives the chief executive the unique number for the certificate; and
 - (b) asks the chief executive for the certificate.

Part 7 Compliance, identification and modification plates

100 Requirements about compliance plates or identification plates on light vehicles

- (1) There must be a compliance plate on a light motor vehicle built from 1 January 1972 to 31 August 1989 (both days included).
- (2) A compliance plate or identification plate must be attached to a light motor vehicle built after 31 August 1989.
- (3) A compliance plate or identification plate must be on or attached to a light motor vehicle in a conspicuous place.
- (4) This section does not apply to—

- (a) a light motor vehicle that—
 - (i) may be imported into Australia without a compliance plate under the repealed *Motor Vehicle Standards Act 1989* (Cwlth) or the *Road Vehicle Standards (Consequential and Transitional Provisions) Act 2018* (Cwlth), schedule 3, part 4; and
 - (ii) complies with each ADR applying to the vehicle under schedule 1, section 21(1) or 22(1); or
- (b) a light motor vehicle for which the chief executive has issued a safe movement permit exempting the vehicle from the requirement for a compliance plate or identification plate to be attached, whether or not—
 - (i) the permit is issued to the current owner or a previous owner; or
 - (ii) the permit has expired; or
- (c) a light vehicle entered on the RAV.

101 Altering, defacing or removing identification plate

- (1) A person must not alter or deface an identification plate on a light vehicle.

Maximum penalty—20 penalty units.

- (2) A person must not remove an identification plate from a light vehicle without the written approval of the chief executive.

Maximum penalty—20 penalty units.

102 Altering, defacing or removing modification plate

- (1) A person must not alter or deface a modification plate on a light vehicle.

Maximum penalty—40 penalty units.

- (2) A person must not remove a modification plate from a light vehicle without the written approval of the chief executive.

Maximum penalty—40 penalty units.

103 Approval to remove identification plate or modification plate from light vehicle

- (1) A person may apply to the chief executive for approval to remove an identification plate or modification plate from a light vehicle.

Note—

See part 8 for provisions relevant to making an application under this section.

- (2) The application must state the reasons for seeking the approval.
- (3) The chief executive must consider the application and decide to approve or refuse the application.
- (4) If the chief executive is satisfied the reasons warrant the removal of the identification plate or modification plate, the chief executive may approve the application.
- (5) The chief executive must give the applicant written notice of the decision.

Part 8 Provisions for applications

104 Definitions for part

In this part—

application means an application made to the chief executive or an authorised officer under this regulation.

decision-maker, for an application, means—

- (a) if the application is made to chief-executive—the chief executive; or
- (b) if the application is made to an authorised officer—the authorised officer.

105 Chief executive may publish notice about applications

(1) The chief executive may, by publishing a notice on the department's website—

(a) approve a way in which an application may be made; or

Examples of ways—

orally, by electronic communication or by another form of communication

(b) require stated information to be included in, or to accompany, an application.

(2) A notice under subsection (1)(a) may include requirements for making an application in the approved way.

(3) A notice under subsection (1)(b) may only require information that is reasonably necessary for—

(a) the decision-maker to decide the application; or

(b) another purpose related to the application or the thing being applied for.

Examples of information that is not reasonably necessary—

- irrelevant personal information
- relevant personal information if the provision of the information would be excessively intrusive to personal privacy

(4) Subsection (1) applies whether or not there is an approved form for the application.

106 How applications must be made

(1) An application must be made in 1 of the following ways—

(a) in the approved form for the application;

(b) in the approved way under section 105(1)(a) for making the application;

(c) if there is no approved form and no approved way for making the application—in writing.

-
- (2) An application must include, or be accompanied by, any information required for the application under section 105(1)(b).
 - (3) Subsection (2) does not limit or otherwise affect another provision of this regulation that requires an application to include, or be accompanied by, particular information.

107 Decision-maker may request further information

- (1) The decision-maker for an application may, by written notice given to the applicant, ask for further information that the decision-maker reasonably needs to decide the application.
- (2) The notice—
 - (a) must state—
 - (i) the information required; and
 - (ii) the time, no earlier than 28 days after the day the notice is given, by which the information is required to be given; and
 - (iii) that the decision-maker may cancel the application if the applicant does not comply with the notice; and
 - (b) may state a way in which the information must be given.
- (3) If the notice does not state a way in which the information must be given, the applicant must give the information in writing.
- (4) If the applicant does not comply with the notice, the decision-maker may give the applicant a written notice cancelling the application.
- (5) The cancellation takes effect on the day the notice cancelling the application is given to the applicant or a later day stated in the notice.

Part 9 General

108 Making, possessing or using false or misleading documents

- (1) A person must not, for this regulation, make, possess or use a document containing information the person knows is false or misleading in a material particular.

Maximum penalty—60 penalty units.

- (2) It is enough for a complaint against a person for an offence against subsection (1) to state that the statement made was ‘false or misleading’ to the person’s knowledge, without specifying which.
- (3) This section does not apply in relation to a document given to the chief executive, the commissioner, an authorised officer or an accredited person.

Note—

See section 53 of the Act in relation to a document given to a person mentioned in subsection (3).

109 Instruments for measuring stationary noise levels—Act, s 123S

- (1) A sound level meter complying with the National Stationary Exhaust Noise Test Procedures is declared to be an instrument for section 123S(1) of the Act, definition *instrument*.
- (2) For section 123S(2) of the Act, for a certificate for an instrument mentioned in subsection (1), if the specified day stated in the certificate is a day on which the instrument is calibrated, the period prescribed is 12 months.
- (3) In this section—

National Stationary Exhaust Noise Test Procedures means the document titled ‘National Stationary Exhaust Noise Test Procedures for In-Service Motor Vehicles’ published on the National Transport Commission’s website.

110 Fees

Fees payable under the Act are stated in schedule 3.

110A Rounding of amounts expressed as numbers of fee units

- (1) This section applies for working out the amount of a fee expressed in this regulation as a number of fee units.
- (2) For the purpose of the *Acts Interpretation Act 1954*, section 48C(3), the amount is to be rounded to the nearest multiple of 5 cents (rounding one-half upwards).

Example—

If a fee were 35 fee units and the value of a fee unit were \$1.015, the number of dollars obtained by multiplying 35 by \$1.015 would be \$35.525. Because \$35.525 is halfway between \$35.50 and \$35.55, it is rounded upwards, so the amount of the fee would be \$35.55.

111 Waiving payment of particular fee in special circumstances

If the chief executive is satisfied that special circumstances exist, the chief executive may waive the payment of the following fees for a person—

- (a) a fee payable under schedule 3, item 2, other than for inspection of a vehicle at an AIS;
- (b) a fee payable under schedule 3, item 4, 11, 13 or 14.

Examples of special circumstances—

- the vehicle has concessional registration for primary production purposes and is in an area or on a property that is drought-stricken
- the vehicle is in a disaster area
- the relevant document is lost, damaged or destroyed because of a disaster

Part 10 Transitional provisions

Division 1 Transitional provisions for SL No. 114 of 2021

112 Definition

In this division—

expired regulation means the expired *Transport Operations (Road Use Management—Vehicle Standards and Safety) Regulation 2010*.

113 Defect notices and defective vehicle labels

- (1) This section applies to—
 - (a) a defect notice issued under the expired regulation if the time for complying with the notice, or an extension of time operating under section 29 of the expired regulation, had not ended before the commencement; or
 - (b) a defective vehicle label attached to a vehicle under the expired regulation if an authorised officer had not removed the label from the vehicle before the commencement.
- (2) The expired regulation continues to apply in relation to the defect notice or defective vehicle label as if that regulation had not expired.
- (3) Without limiting subsection (2), a person may apply under section 29 of the expired regulation for an extension of time to comply with the defect notice.

114 Chief executive approval of modification of vehicle

If, before the commencement, the chief executive approved a modification of a light vehicle, the chief executive is taken to have approved the modification under section 23.

115 Certificate of modification or modification plate

- (1) This section applies in relation to a modification of a vehicle if, under the expired regulation—
 - (a) a certificate of modification was issued for the modification; or
 - (b) a modification plate for the modification was attached to the vehicle.
- (2) The certificate of modification is taken to have been issued for the modification under part 3, division 3.
- (3) The modification plate for the modification is taken to have been attached to the vehicle under part 3, division 3.

116 Guideline or permit for safe movement of light vehicles

- (1) A guideline for the safe movement on a road of a type of light vehicle issued under the expired regulation and in effect immediately before the commencement is taken to be a safe movement guideline issued under section 53.
- (2) Subsection (3) applies to a permit for the safe movement on a road of a particular light vehicle granted by the chief executive or commissioner under the expired regulation if the term of the permit had not ended before the commencement.
- (3) The permit—
 - (a) is taken to be a safe movement permit for the particular light vehicle granted by the chief executive under section 54; and
 - (b) continues in effect until the end of the term for which the permit was granted under the expired regulation.

117 Existing authorisation for approved examiner to approve certificates of inspection

- (1) This section applies if—
 - (a) under section 19A of the expired regulation, the chief executive authorised an approved examiner to approve a

[s 118]

certificate of inspection for a type of vehicle stated in notice of the authorisation; and

- (b) on the commencement, the period of the authorisation stated in the notice had not ended.
- (2) The authorisation—
- (a) is taken to have been given by the chief executive under section 78; and
 - (b) ends when the period for which the authorisation was given under the expired regulation ends.

118 Certificates of inspection issued for COI vehicles before commencement

- (1) For section 71, a reference to a certificate of inspection in effect for a vehicle includes a reference to a certificate of inspection issued for the vehicle under the expired regulation while, under section 28 of the expired regulation, the certificate would be current.
- (2) Section 71(1) does not apply to a person while an extension of time for complying with section 25 of the expired regulation would, but for the expiry of the expired regulation, be operating under section 29 of the expired regulation.

119 Inspection certificates issued before commencement

For section 75, a reference to an inspection certificate in effect for a vehicle includes a reference to an inspection certificate issued for the vehicle under the expired regulation while, under section 28 of the expired regulation, the certificate would be current.

120 Exemption from requirement for certificate of inspection for former Warroo local government area

- (1) This section applies to the owner of a registered COI vehicle until 31 August 2022.

-
- (2) Section 71(1) does not apply to the owner if the COI vehicle is being used only in the former local government area.
 - (3) Section 75(1) does not apply if the owner—
 - (a) lives in the former local government area; and
 - (b) disposes of the vehicle in the former local government area.
 - (4) Section 76(1) does not apply to a dealer acting for the owner to dispose of the COI vehicle if the owner—
 - (a) lives in the former local government area; and
 - (b) disposes of the vehicle in the former local government area.

- (5) In this section—

former local government area means the area that, immediately before 15 March 2008, was the local government area of the Warroo Shire Council.

Note—

Under the *Local Government Act 1993* as in force immediately before 15 March 2008, shires and cities were described in the *Local Government (Areas) Regulation 2005*, schedule 1 as in force immediately before that day.

121 Inspection report issued for vehicle

- (1) This section applies if—
 - (a) an inspection report was issued for a vehicle under the expired regulation on or after 17 August 2021; and
 - (b) on the commencement, the vehicle had not been returned for reinspection under section 21 of the expired regulation after the issue of the inspection report.
- (2) The inspection report is taken to have been issued under section 86 on the day it was issued under the expired regulation.

122 Refusal of registration for contravention of Act

- (1) For part 6, division 5, subdivision 3—
 - (a) it does not matter whether the refusal of an application for the registration of a vehicle mentioned in section 93 happened before or after the commencement; and
 - (b) a reference to an inspection certificate for a vehicle includes an inspection certificate issued under the expired regulation before the commencement.
- (2) Subsection (3) applies if—
 - (a) before the commencement, a person asked the proprietor of the AIS where an inspection certificate was issued to again inspect the vehicle for an inspection certificate under section 20(2) of the expired regulation; and
 - (b) on the commencement, the vehicle had not been inspected again as required under section 20(3) of the expired regulation.
- (3) Section 20 of the expired regulation continues to apply in relation to the person's request as if that regulation had not expired.

123 Chief executive's approval to remove modification plate or identification plate from light vehicle

- (1) For section 102(2), it does not matter whether the chief executive's approval to remove a modification plate from a light vehicle was given before or after the commencement.
- (2) For section 103(2), it does not matter whether the chief executive's approval to remove a modification plate from a light vehicle was given before or after the commencement.

124 Existing applications

- (1) This section applies to an application to the chief executive or an authorised officer made, but not decided, under the expired regulation before the commencement.

-
- (2) The application is taken to have been made under this regulation.
 - (3) Anything done in relation to the application under the expired regulation is taken to have been done in relation to the application under this regulation.

125 Approved forms under expired regulation

- (1) A form that, immediately before the commencement, was an approved form for an application, certificate, notice or other document under the expired regulation is taken to be an approved form for an application, certificate, notice or other document of the same kind under this regulation.
- (2) A form that, immediately before the commencement, was an approved form for a modification plate under the expired regulation is taken to be an approved form for a modification plate under this regulation.

126 Application of sch 1, ss 144A and 144B

Schedule 1, sections 144A and 144B do not apply in relation to a vehicle that, on 1 October 2020, was a registered vehicle until—

- (a) the vehicle’s registration expires or is cancelled; or
- (b) 1 October 2021.

127 Particular references in documents

In a document—

- (a) a reference to the expired regulation is, if the context permits, taken to be a reference to this regulation; and
- (b) a reference to the approved code of practice titled ‘Code of Practice—Vehicle Inspection Guidelines’ mentioned in section 7(1)(f) of the expired regulation is, if the context permits, taken to be a reference to the light vehicle standards (safety inspection); and

- (c) a reference to an approved code of practice under section 13(7) of the expired regulation is, if the context permits, taken to be a reference to the light vehicle standards (modification).

Division 2 Transitional provision for Transport Legislation Amendment Regulation (No. 2) 2021

128 Certificates of inspection issued for particular vehicles before commencement

- (1) This section applies to a certificate of inspection—
 - (a) issued for—
 - (i) a public passenger vehicle, other than a booked hire vehicle, limousine or taxi; or
 - (ii) a bus, other than a relevant bus; and
 - (b) in effect immediately before the commencement.
- (2) The certificate of inspection continues in effect until it would have ended under former section 66 as if the *Transport Legislation Amendment Regulation (No. 2) 2021* had not been made.

- (3) In this section—

former section 66 means section 66 as in force before the commencement.

public passenger vehicle see the *Transport Operations (Passenger Transport) Act 1994*, schedule 3.

relevant bus means a bus, other than a bus used to provide a public passenger service, that is—

- (a) built to carry 12 or fewer seated adults; or
- (b) used for a private purpose; or
- (c) used for driver tuition.

Division 3 **Transitional provisions for Transport and Other Legislation Amendment Regulation 2026**

129 **Definitions for division**

In this division—

relevant vehicle see the *Transport Operations (Passenger Transport) Regulation 2018*, schedule 9.

repealed standard means the repealed *Transport Operations (Passenger Transport) Standard 2010*.

130 **Warning signs and warning lights fitted to school bus immediately before 1 October 1999**

- (1) Schedule 1, part 7, division 19 does not apply to a relevant vehicle if—
- (a) immediately before the commencement—
 - (i) the vehicle was a school bus within the meaning of the repealed standard, schedule 4; and
 - (ii) the bus complied with the repealed standard, section 44; and
 - (b) from the commencement, the vehicle continues to comply with former section 18B as if that section were still in force.

Note—

See also the Queensland Road Rules, sections 222 and 222A.

- (2) In this section—

former section 18B means the *Traffic Regulation 1962*, schedule 1, section 18B, as it was in force immediately before 1 October 1999.

131 Warning signs and lights fitted to bus under repealed standard

- (1) Schedule 1, part 7, division 19 does not apply to a relevant vehicle if—
- (a) immediately before the commencement—
 - (i) the vehicle was a bus within the meaning of the repealed standard; and
 - (ii) the bus complied with the repealed standard, schedule 1, part 4; and
 - (b) from the commencement, the vehicle continues to comply with the repealed standard, schedule 1, part 4 as if the amendment regulation had not been made and the repealed standard, schedule 1, part 4 were still in force.

Note—

See also the Queensland Road Rules, sections 222 and 222A.

- (2) In this section—

amendment regulation means the *Transport and Other Legislation Amendment Regulation 2026*.

Schedule 1 Light vehicle standards (model provisions)

section 6(3)

Note—

To ensure the greatest possible national consistency for standards for light vehicles, the provisions of this schedule are modelled on the Australian Light Vehicle Standards Rules 2015 published on the website of the Australasian Parliamentary Counsel's Committee. Accordingly, the provisions are not entirely consistent with Queensland's current drafting style.

Part 1 Preliminary

Note—

The following note is from the Australian Light Vehicle Standards Rules 2015—

The Australian Light Vehicle Standards Rules 2015 set vehicle standards that vehicles must comply with to be driven on roads and road-related areas.

The ADRs (Australian Design Rules) are rules for designing and building vehicles. Imported vehicles must also comply with the ADRs.

The Light Vehicle Standards require a vehicle that is subject to an ADR when built or imported to continue to comply with the ADR.

The Light Vehicle Standards also apply particular other standards (adopted standard) that are intended to complement the ADRs.

The ADRs do not cover—

- vehicles built before 1969
- combinations of vehicles of any age
- every safety feature for vehicles built between 1969 and 1988.

These matters are covered by the Light Vehicle Standards.

In most cases, if a vehicle complies with these vehicle standards, it is suitable for road use.

1 Sections 1 and 2 not used

Note—

To maximise consistency between this schedule and the Australian Light Vehicle Standards Rules 2015, the numbers of some provisions not relevant to the operation of this regulation have not been used in the numbering of this schedule, unless required for provisions particular to the State. Each provision number that is not used is identified in this schedule.

Part 2 Interpretation and application of vehicle standards

3 Definitions for schedule

In this schedule—

adopted standard means a standard, other than an ADR, that is applied, adopted or incorporated by a provision of this schedule.

Example—

Section 51(1)(c) applies AS 1973—1976 (Australian Standard for retreaded pneumatic passenger car tyres).

ADR means—

- (a) a second edition ADR; or
- (b) a third edition ADR.

air brake means a brake that is air-operated or air-assisted.

Airservices Australia see the *Air Services Act 1995* (Cwlth), section 7.

Airservices Australia vehicle means a vehicle driven by any of the following persons in the course of the person's duty to Airservices Australia—

- (a) the chief executive officer of Airservices Australia appointed under the *Air Services Act 1995* (Cwlth), section 34;

- (b) a person appointed to act as chief executive officer of Airservices Australia under the *Air Services Act 1995* (Cwlth), section 41;
- (c) a person employed under the *Air Services Act 1995* (Cwlth), section 42;
- (d) a person engaged as a consultant under the *Air Services Act 1995* (Cwlth), section 43.

air storage tank, of a vehicle, means a tank fitted to the vehicle for storing compressed air.

Australian Border Force vehicle means a vehicle driven by an immigration and border protection worker, within the meaning of the *Australian Border Force Act 2015* (Cwlth), section 4(1), in the course of the worker's duty to the Australian Border Force under that Act.

axle group means a single axle group, tandem axle group or tri-axle group.

braking system, of a vehicle, means all the brakes of the vehicle and all the components of the mechanisms by which the brakes are operated.

British Standard means a standard approved for publication for the British Standards Institution.

Note—

Copies of British Standards are available for purchase from Standards Australia.

British Standards Institution means the institution of that name established under royal charter in the United Kingdom.

car means a motor vehicle built mainly to carry people that—

- (a) seats 9 or fewer adults; and
- (b) has a body commonly known as a sedan, hatchback, station wagon, coupe, convertible, or roadster; and
- (c) has 4 or more wheels.

centre line means—

- (a) for an axle—

Schedule 1

- (i) if the axle consists of 1 shaft—a line parallel to the length of the axle and passing through the centre of the axle; or
- (ii) if the axle consists of 2 shafts—a line in the vertical plane passing through—
 - (A) the centre of both shafts; and
 - (B) the centres of the wheels on the shafts; or
- (b) for an axle group—
 - (i) if the group consists of 2 axles, one of which is fitted with twice the number of tyres as the other axle—a vertical line located one-third from the centre line of the axle with more tyres towards the centre line of the axle with fewer tyres; or
 - (ii) otherwise—a line located midway between the centre lines of the outermost axles of the group.

Example of the centre line of a tandem axle group fitted with an equal number of tyres on each axle—

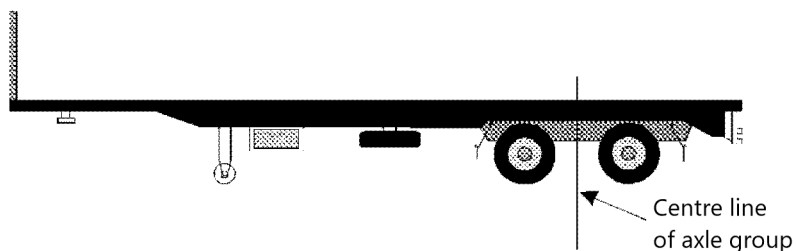

Example of the centre line of a tandem axle group fitted with a different number of tyres on each axle—

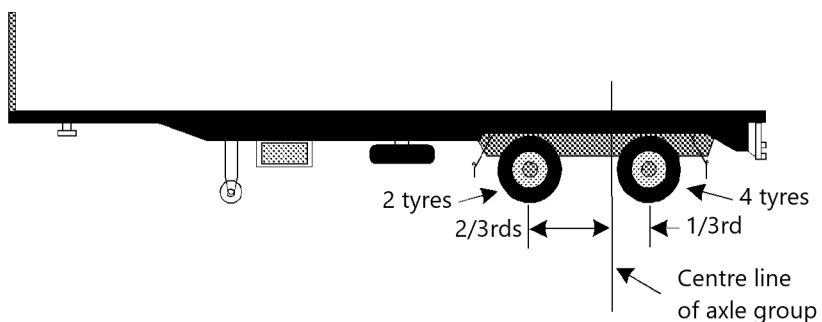

Example of the centre line of a tri-axle group—

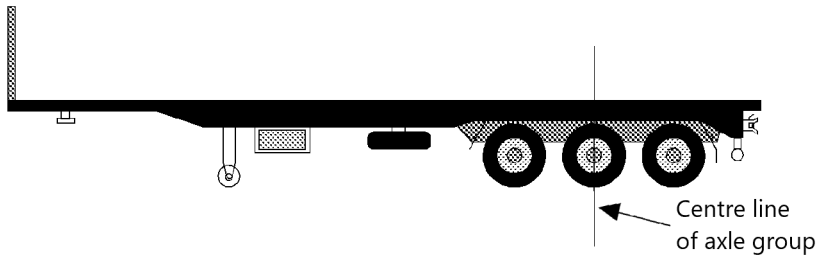

converter dolly means a trailer with a single axle or 1 axle group, and a fifth wheel coupling, designed to convert a semitrailer into a dog trailer.

Example of converter dolly—

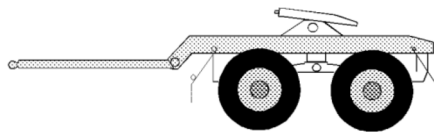

daylight means the period in a day from sunrise to sunset.

diesel engine means an engine, commonly known as a diesel engine, that works on the compression-ignition principle.

dog trailer means a trailer (including a trailer consisting of a semitrailer and converter dolly) with—

- (a) a single axle or 1 axle group at the front that is steered by connection to a towing vehicle by a drawbar; and
- (b) a single axle or 1 axle group at the rear.

Example of a dog trailer—

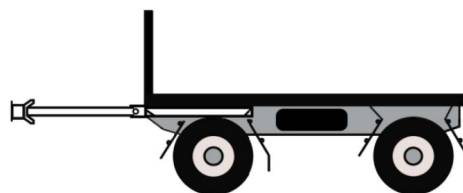

drawbar means a part of a trailer, other than a semitrailer, connecting the trailer body to a coupling for towing purposes.

emergency brake means a brake designed to be used if a service brake fails.

emergency vehicle means a motor vehicle—

- (a) fitted with—
 - (i) a repeater horn or siren; or
 - (ii) a flashing warning light; and
- (b) driven by—
 - (i) an officer of the Queensland Ambulance Service or an ambulance service of another State in the course of the officer's duty; or
 - (ii) an officer of Queensland Fire and Rescue, Rural Fire Service Queensland (other than a rural fire brigade under the *Fire Services Act 1990*) or a fire and emergency service, however called, of another State in the course of the officer's duty; or
 - (iii) an officer or employee of another entity with the written permission of the commissioner in the course of the officer's or employee's duty.

fifth wheel coupling, for a combination, means a device, other than the upper rotating element and the kingpin of a semitrailer, used with a converter dolly, prime mover or semitrailer to allow quick coupling and uncoupling of the vehicles that are part of the combination and to provide for articulation for the combination.

front fog light means a light used to improve the illumination of the road during a dust storm, fog, heavy rain or snowfall.

goods vehicle means a goods vehicle as defined under the ADR (definitions and vehicle categories).

GTM (gross trailer mass) means the mass transmitted to the ground by the axles of a trailer when the trailer is loaded to its GVM and connected to a towing vehicle.

high-beam, for a headlight or front fog light fitted to a vehicle, means the light is built or adjusted so, when the vehicle is standing on level ground, the top of the main beam

of light projected is above the top of the main beam of light that would be projected by the light in the low-beam position.

left, for a vehicle, means to the left of the centre of the vehicle when viewed by a person in the vehicle facing to the front of the vehicle.

low-beam, for a headlight or front fog light fitted to a vehicle, means the light is built or adjusted so the top of the main beam of light it projects, when the vehicle is standing on level ground, is no higher than—

- (a) the centre of the light, when measured 8m in front of the vehicle; and
- (b) 1m above the ground, when measured 25m in front of the vehicle.

Example of headlights in the low-beam position—

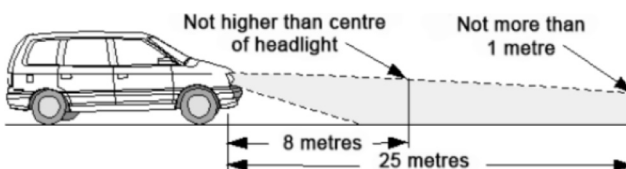

moped means a motorbike or motortrike with—

- (a) an engine cylinder capacity of not more than 50ml; and
- (b) a maximum speed of not more than 50km/h.

motorbike does not include a motortrike.

Note—

See also the definition *motorbike* in schedule 4 of the Act.

motortrike means a motor vehicle with 3 wheels, other than a motor vehicle with 2 wheels and a sidecar supported by a third wheel.

mudguard means a fitting or device, with or without a mudflap, built and fitted to a vehicle in a way that will, as far as practicable, catch or deflect downwards any mud, stone, water or other substance thrown up by the rotation of the wheel of the vehicle for which the fitting or device is fitted.

nearer side of the vehicle, in relation to a light or reflector fitted to a vehicle, means the side of the vehicle closest to the light or reflector.

parking brake, of a vehicle, means the brake usually used to keep the vehicle stationary while the vehicle is parked.

point of articulation means—

- (a) the axis of a kingpin for a fifth wheel; or
- (b) the vertical axis of rotation for each of the following—
 - (iii) a fifth wheel coupling;
 - (iv) a front axle group or single axle of a dog trailer;
 - (vi) a turntable assembly; or
- (c) a coupling pivot point of a semitrailer.

Example of the point of articulation on a converter dolly (fifth wheel coupling)—

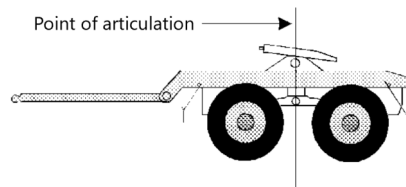

Example of the point of articulation on a prime mover (fifth wheel)—

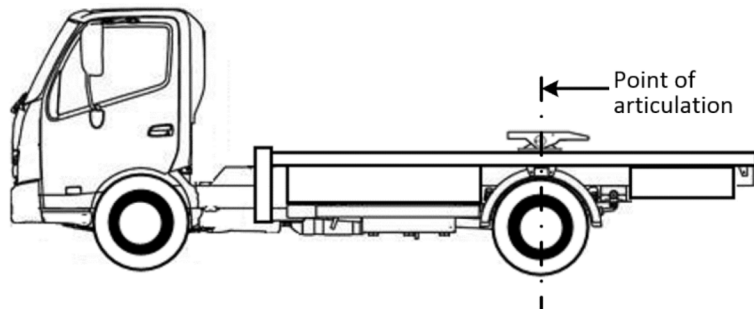

Example of point of articulation for a fifth wheel (king pin)—

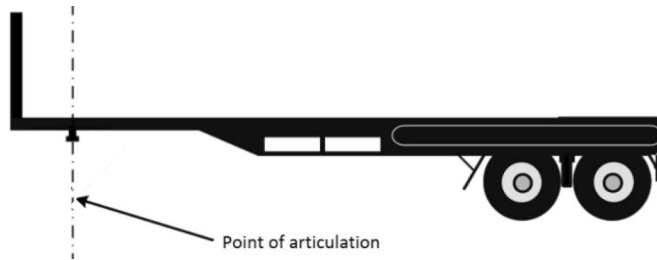

police vehicle means a vehicle driven by a police officer of the Queensland Police Service, or the police service of the Commonwealth or another State, in the course of the police officer's duty.

rear fog light see section 102(4).

rear overhang, of a vehicle, see section 60(1).

rear overhang line, of a vehicle, see section 60(2), (3) and (4).

repeater horn means a device that makes a sound alternating between different tones or frequencies on a regular time cycle.

right, for a vehicle, means to the right of the centre of the vehicle when viewed by a person in the vehicle facing to the front of the vehicle.

second edition ADR means an Australian Design Rule—

- (a) incorporated in the document described as the Australian Design Rules for Motor Vehicle Safety, Second Edition; and
- (b) originally published by the then Commonwealth Department of Transport.

service brake, for a vehicle, means the brake normally used to decelerate the vehicle.

side marker light means a light fitted to a side of a vehicle indicating the presence and length of the vehicle when viewed on that side.

single axle means an axle not part of an axle group.

single axle group means a group of at least 2 axles with a horizontal distance of less than 1m between the centre lines of the outermost axles of the group.

street rod vehicle means a vehicle that is—

- (a) either—
 - (i) a vehicle with a body and frame built before 1949; or
 - (ii) a vehicle that is a replica of a vehicle mentioned in subparagraph (i); and
- (b) modified for safe road use.

tandem axle group means a group of at least 2 axles with a horizontal distance of at least 1m, but not more than 2m, between the centre lines of the outermost axles of the group.

third edition ADR means—

- (a) a national standard under the repealed *Motor Vehicle Standards Act 1989* (Cwlth) before its repeal; or
- (b) a national road vehicle standard under the *Road Vehicle Standards Act 2018* (Cwlth), section 12.

transport enforcement vehicle means a vehicle marked as a departmental vehicle and used by the department for enforcement purposes.

tri-axle group means a group of at least 3 axles with a horizontal distance of more than 2m, but not more than 3.2m, between the centre lines of the outermost axles.

turntable means a bearing built to carry vertical and horizontal loads that—

- (a) does not allow quick separation of its upper and lower rotating elements; and
- (b) is used to connect and allow articulation between—
 - (i) a prime mover and semitrailer; or
 - (ii) the steering axle or axle group of a dog trailer and the body of the trailer; or

- (iii) a fifth wheel coupling and the vehicle to which it is mounted.

vacuum brakes means brakes that are vacuum-operated or vacuum-assisted.

vacuum storage tank, for a vehicle, means a tank fitted to the vehicle for storing air at low pressure.

warning light means a light, fitted to a vehicle, designed specifically to warn road users of the vehicle's presence on a road.

yellow includes amber.

4 References to vehicle, motor vehicle or trailer

- (1) A reference in this schedule to a vehicle is taken to be a reference to a light vehicle.
- (2) A reference in this schedule to a motor vehicle is taken to be a reference to a light motor vehicle.
- (3) A reference in this schedule to a trailer is taken to be a reference to a light trailer.

Note—

Subsections (2) and (3) are additional Queensland provisions.

5 When restored vehicle is built

- (1) A restored vehicle is taken to have been built when the vehicle was originally built and not when the vehicle was restored.
- (2) In this section—

restored vehicle means a vehicle that is being, or has been, restored to the vehicle's manufacturer's specifications, to the extent it is practicable to meet the specifications.

6 Measurement of width of vehicles

The width of a vehicle is measured disregarding any of the following fitted to the vehicle—

- (a) an anti-skid device mounted on a wheel;
- (b) a central tyre inflation system;
- (c) a side marker light;
- (d) a mirror;
- (e) a reflector;
- (f) a signalling device;
- (g) a tyre pressure gauge;
- (h) a permanently fixed webbing assembly-type device if the maximum distance across the body of the vehicle, including any part of the device, is not more than 2.55m.

Example of a permanently fixed webbing assembly-type device—
a curtain side device

7 Sections 7–14 not used

See note to section 1.

15 Application to vehicle or coupling complying with inconsistent ADR requirement

- (1) A requirement of parts 4 to 10 does not apply to a vehicle if—
 - (a) the vehicle complies with a requirement of an ADR that applies to—
 - (i) the vehicle; or
 - (ii) vehicles of the same class or type manufactured after the vehicle; and
 - (b) the ADR requirement corresponds to a requirement in parts 4 to 10.

Example—

As the second and third edition ADR do not apply to a vehicle built in 1968, the vehicle must comply with section 123. If the owner of that type of vehicle modified the brakes so the vehicle did comply with the second edition ADR, a requirement in section 123 about the vehicle's brakes that is inconsistent with the second edition ADR no longer applies to the vehicle.

-
- (2) A requirement of part 11 does not apply to a coupling if—
- (a) the coupling complies with a requirement of an ADR that applies to—
 - (i) the coupling; or
 - (ii) couplings of the same class or type manufactured after the coupling; and
 - (b) the ADR requirement corresponds to a requirement in part 11.
- (3) Despite subsection (1), a requirement of the following provisions applies to a vehicle instead of the corresponding ADR requirement—
- (aa)
 - Note—*
 - Paragraph is not used. See note to section 1.
 - (a) section 44(5), (6), (7) and (8);
 - (b) section 50;
 - (c) section 114(4).
 - (d)
 - Note—*
 - Paragraph is not used. See note to section 1.
- (4) In this section—
- vehicle** includes a vehicle that has been modified to comply with the ADR requirement.

16 Non-application to vehicles subject to particular approvals

- A provision of parts 4 to 10 does not apply to a vehicle if—
- (a) the vehicle does not comply with a requirement of an ADR applying to the vehicle; and
 - (b) the provision corresponds to the requirement of the ADR; and
 - (c) despite the noncompliance—

- (i) an approval was given under the repealed *Motor Vehicle Standards Act 1989* (Cwlth), section 10A(2) or (3) for identification plates to be placed on vehicles of that type; or
 - (ii) an approval is given under the *Road Vehicle Standards (Consequential and Transitional Provisions) Act 2018* (Cwlth), schedule 3, item 4(2) or 6(2) in relation to vehicles of that type; or
 - (iii) for a vehicle to which the *Road Vehicle Standards Rules 2019* (Cwlth), section 15(2) applies—the vehicle satisfies the requirements, under section 15(1) of those rules, of the type approval pathway for the type of vehicle; and
- (d) the vehicle complies with any conditions of the relevant approval.

Notes—

- 1 The repealed *Motor Vehicle Standards Act 1989* (Cwlth), section 10A(2) deals with motor vehicles that do not comply with an ADR, but the noncompliance is only minor and inconsequential.
- 2 The repealed *Motor Vehicle Standards Act 1989* (Cwlth), section 10A(3) deals with motor vehicles that do not comply with an ADR and the noncompliance is not minor and inconsequential, but the vehicle will be safe to use if conditions are complied with.

17 Interpretation of particular second edition ADRs

In a provision of the following second edition ADRs, when applied under this schedule to a motor vehicle with a left-hand drive, the words ‘left’ and ‘right’ have the opposite meaning—

- (a) ADR 8 Safety Glass;
- (b) ADR 12 Glare Reduction in Field of View;
- (c) ADR 14 Rear Vision Mirrors;
- (d) ADR 16 Windscreen Wipers and Washers;
- (e) ADRs 18 and 18A Location and Visibility of Instruments;

- (f) ADRs 35 and 35A Commercial Vehicle Braking Systems.

18 Reference to adopted standards

- (1) Unless a contrary intention appears, a reference in a provision of this schedule to an adopted standard is a reference to the adopted standard—
 - (a) for an adopted standard referenced using an alphanumeric designation—as in force under that designation; and
 - (b) as in force—
 - (i) if the adopted standard was also an adopted standard mentioned in a provision of schedule 1 of the expired regulation—when the provision of schedule 1 of that regulation commenced; or
 - (ii) otherwise—when the provision of this schedule commenced.
- (2) The words appearing in brackets after the alphanumeric designation used to refer to an adopted standard are included for information purposes only.
- (3) In this section—

expired regulation means the *Transport Operations (Road Use Management—Vehicle Standards and Safety) Regulation 2010* as in force from time to time before it expired.

Note—

Subsections (1)(a) and (b)(i), (2) and (3) are additional Queensland provisions.

19 Compliance with particular adopted standards

A vehicle is taken to comply with an adopted standard if—

- (a) the standard is replaced by, or is inconsistent with, a later version of the standard; and
- (b) the vehicle complies with the later version of the standard.

Example—

A vehicle is taken to comply with the replaced AS 1973—1976 (Australian Standard for retreaded pneumatic passenger car tyres) if the vehicle complies with the later AS 1973—1993 (Australian Standard for pneumatic tyres—passenger car, light truck, and truck/bus—retreading and repair processes).

20 Section 20 not used

See note to section 1.

Part 3 Australian Design Rules

Division 1 Compliance with ADRs

21 Second edition ADRs

- (1) If a second edition ADR recommends that the ADR should apply to the design and construction of a vehicle, the vehicle must comply with the ADR.
- (2) If a requirement of a second edition ADR applies to a type of equipment fitted to a vehicle built on or after a stated time, equipment of the same type fitted to the vehicle after the vehicle is built must comply with—
 - (a) the requirement as in force when the vehicle is built; or
 - (b) if the requirement is amended after the vehicle is built and before the equipment is fitted—the requirement as in force—
 - (i) when the vehicle is built; or
 - (ii) when the equipment is fitted; or
 - (iii) at any time between when the vehicle is built to when the equipment is fitted.
- (3) However, a vehicle, or equipment fitted to a vehicle, need not comply with a recommendation or requirement of a second edition ADR if—

- (a) the recommendation or requirement is replaced by, or is inconsistent with, a requirement of either of the following (each a *later ADR*)—
 - (i) a later version of the second edition ADR applying to the vehicle or equipment;
 - (ii) a third edition ADR applying to the vehicle or equipment; and
 - (b) the vehicle or equipment complies with the requirement of the later ADR.
- (4) If a second edition ADR allows a vehicle built on or after a stated time to be fitted with equipment, a vehicle built before the time may also be fitted with the equipment.

22 Third edition ADRs

- (1) If a third edition ADR applies to the design and construction of a vehicle, the vehicle must comply with the ADR.
- (2) If a requirement of a third edition ADR applies to a type of equipment fitted to a vehicle built on or after a stated time, equipment of the same type fitted to the vehicle after the vehicle is built must comply with—
 - (a) the requirement as in force when the vehicle is built; or
 - (b) if the requirement is amended after the vehicle is built and before the equipment is fitted—the requirement as in force—
 - (i) when the vehicle is built; or
 - (ii) when the equipment is fitted; or
 - (iii) at any time between when the vehicle is built to when the equipment is fitted.
- (3) However, a vehicle, or equipment fitted to a vehicle, need not comply with a requirement of a third edition ADR if—
 - (a) the requirement is replaced by a requirement of a later version of the ADR applying to the vehicle or equipment; and

- (b) the vehicle or equipment complies with the requirement of the later version.
- (4) If a third edition ADR allows a vehicle built on or after a stated time to be fitted with equipment, a vehicle built before the time may be fitted with the equipment.
- (5) A reference in a third edition ADR to an expression appearing in the following table (the *ADR expression*) is taken to be a reference to the expression used in this schedule appearing opposite the ADR expression.

ADR expression	Expression used in this schedule
dipped-beam headlamp	low-beam, for a headlight
front fog lamp	front fog light
rear fog lamp	rear fog light
wheelguard	mudguard
main-beam headlamp	high-beam, for a headlight
reversing lamp	reversing light
direction indicator lamp	direction indicator light
stop lamp	brake light
rear registration plate lamp	number plate light
front position (side) lamp	parking light
rear position (side) lamp	tail light
end-outline marker lamp	front or rear clearance light
external cabin lamp	external cabin light
internal lamp	interior light
side marker lamp	side marker light
daytime running lamp	daytime running light
rear reflex reflector, non-triangular	rear reflector
front reflex reflector, non-triangular	front reflector
side reflex reflector, non-triangular	side reflector

Division 2 Exemptions from compliance with ADRs

23 Vehicles that are not road vehicles

A vehicle need not comply with an ADR applied by section 21(1) or 22(1) if—

- (a) a determination or declaration under the repealed *Motor Vehicle Standards Act 1989* (Cwlth), section 5B provided that the vehicle is not a road vehicle for that Act; or
- (b) a determination under the *Road Vehicle Standards Act 2018* (Cwlth), section 6(5)(b) or (6)(b) provides that the vehicle is not a road vehicle for that Act.

24 Vehicles subject to particular approvals

(1) A vehicle need not comply with an ADR applied by section 21(1) or 22(1) if—

- (a) despite noncompliance with the ADR—
 - (i) an approval was given under the repealed *Motor Vehicle Standards Act 1989* (Cwlth), section 10A(2) or (3) to place identification plates on vehicles of that type; or
 - (ii) an approval is given under the *Road Vehicle Standards (Consequential and Transitional Provisions) Act 2018* (Cwlth), schedule 3, item 4(2) or 6(2) in relation to vehicles of that type; and
- (b) the vehicle complies with any conditions of the approval.

(2) A vehicle need not comply with an ADR applied by section 21(1) or 22(1) if—

- (a) either—
 - (i) the vehicle was permitted to be supplied to the market under an approval given under the repealed

Motor Vehicle Standards Act 1989 (Cwlth), section 14A(1); or

- (ii) an approval is given under the *Road Vehicle Standards (Consequential and Transitional Provisions) Act 2018* (Cwlth), schedule 3, item 11(2) in relation to the vehicle; and
 - (b) the vehicle complies with any conditions of the approval.
- (3) A vehicle need not comply with an ADR applied by section 21(1) or 22(1) if—
- (a) the vehicle was permitted to be used in transport in Australia under an approval given under the repealed *Motor Vehicle Standards Act 1989* (Cwlth), section 15(2); and
 - (b) the vehicle complies with any conditions of the approval.

24A Vehicles subject to particular approvals etc. under Road Vehicle Standards Act 2018 (Cwlth)

A vehicle need not comply with an ADR applied by section 21(1) or 22(1) if the vehicle—

- (a) is a vehicle to which the *Road Vehicle Standards Rules 2019* (Cwlth), section 15(2) applies; and
- (b) satisfies the requirements, under section 15(1) of those rules, of the type approval pathway for the type of vehicle.

25 Partial exemption for personally imported vehicles

- (1) A personally imported vehicle must be fitted with—
- (a) seatbelts that are at least as effective as seatbelts that meet an Australian Standard or British Standard for seatbelts as in force 1 September 2010; and

-
- (b) seatbelt anchorages that meet the number and location requirements of second edition ADR 5a or 5b or third edition ADR 5; and
 - (c) child restraint anchorages that meet the number, location, accessibility, thread size and form requirements of second edition ADR 34 or third edition ADR 5 or 34; and
 - (d) head restraints that meet the number, location and size requirements of second edition ADR 22 or third edition ADR 22.
- (2) However, a personally imported vehicle need only meet the requirements of an ADR mentioned in subsection (1) if the ADR recommends that it should apply, or applies, to a vehicle of the same type.
- (3) A personally imported vehicle need not otherwise comply with an ADR applied by section 21(1) or 22(1).

- (4) In this section—

personally imported vehicle means a vehicle built after 1968 that is imported into Australia by a person who—

- (a) before the vehicle was imported into Australia, owned and used the vehicle for a continuous period of at least—
 - (i) if the vehicle was owned by the person before 9 May 2000—3 months; or
 - (ii) otherwise—1 year; and
- (b) has—
 - (i) if the vehicle was imported before the repeal of the repealed *Motor Vehicle Standards Act 1989* (Cwlth)—undertaken to comply with any requirements relating to road safety imposed for the vehicle under the repealed *Motor Vehicle Standards Regulations 1989* (Cwlth); or
 - (ii) if the vehicle is imported during the transitional period under the *Road Vehicle Standards (Consequential and Transitional Provisions) Act*

2018 (Cwlth)—undertaken to comply with any requirements relating to road safety applying to the vehicle under that Act; or

- (iii) otherwise—complied with the rules made under the *Road Vehicle Standards Act 2018* (Cwlth) in relation to the vehicle.

Note—

Paragraph (b)(ii) of this definition is an additional Queensland provision.

Part 4 General safety requirements

Division 1 All vehicles

26 Steering

- (1) A motor vehicle must have a right-hand drive if the vehicle is less than 30 years old.
- (2) A motor vehicle has a right-hand drive if the centre of at least 1 steering control of the vehicle is to the right of, or in line with, the centre of the vehicle.
- (3) For a motor vehicle built before 1 January 2005, a component of the vehicle’s steering system essential for effective steering of the vehicle must be built to transmit energy by mechanical means only.
- (4) Failure of a non-mechanical component of the steering system must not prevent effective steering of the vehicle.
- (5) This section does not apply to a motor vehicle if the vehicle is built mainly for a purpose other than the transport of goods or people by road.
- (6) A motor vehicle to which the third edition ADR 42 applies and that is at least 30 years old may have a left hand drive.

27 Turning ability

- (1) A motor vehicle must be able to turn in a circle of not more than 25m in diameter, measured by the outer edge of the tyre track at ground level.
- (2) The vehicle must be able to comply with subsection (1) whether it turns to the left or to the right.

28 Ability to travel backwards and forwards

A motor vehicle with an unloaded mass of more than 450kg must be able to be driven both backwards and forwards when the vehicle's driver is in the normal driving position of the vehicle.

29 Protrusions

- (1) An object fitted to a vehicle must be designed, built and fitted to the vehicle in a way that minimises the likelihood of injury to a person making contact with the vehicle.
- (2) However, subsection (1) does not apply to an object fitted to a vehicle if—
 - (a) the vehicle was designed before 1965 and the object was part of the design of the vehicle; or
 - (b) the object was fitted to the vehicle before 1965 in accordance with the law of the place where the object was fitted.

29A Section 29A not used

See note to section 1.

30 Driver's view and vehicle controls

A motor vehicle must be built—

- (a) to allow the driver a view of the road and of traffic to the front and sides of the vehicle so the driver can drive the vehicle safely; and

- (b) with its controls located so the driver can drive the vehicle safely.

31 Seating

A seat for a driver or passenger in a vehicle must be securely attached to the vehicle.

32 Mudguards

- (1) A vehicle must have a mudguard firmly fitted for each wheel or adjacent wheels.
- (2) However, subsection (1) does not apply to a vehicle if—
 - (a) the construction or use of the vehicle makes the fitting of mudguards unnecessary or impracticable; or
 - (b) the body or part of the body of the vehicle acts as a mudguard.

Examples for subsection (2)(a)—

- most road-making plant
 - some agricultural equipment
- (3) The lowest point of a mudguard must not be more than—
 - (a) 230mm above ground level; or
 - (b) for a vehicle built to be used off-road—300mm above ground level.
 - (4) The outside of a rear mudguard of a vehicle, other than a mudflap, that can be seen from behind the vehicle must be coloured white or silver if the vehicle—
 - (a) is at least 2.2m wide; and
 - (b) has a body with a vertical measurement of less than 300mm at the rear, measured from the lowest point of the body above ground level to the highest point; and
 - (c) is not fitted with rear marking plates or conspicuity markings in accordance with section 115.

- (5) Subsections (3) and (4) do not apply to a moped, motorbike or motortrike.

33 Horns, alarms etc.

- (1) A motor vehicle must be fitted with at least 1 horn or other device that can give sufficient audible warning to other road users of the approach or position of the vehicle.
- (2) A motor vehicle must not be fitted with a device that can make a sound like the sound of a siren, exhaust whistle, compression whistle or repeater horn.
- (3) However, subsection (2) does not apply to the following motor vehicles—
- (a) a police vehicle;
 - (b) an emergency vehicle;
 - (c) a transport enforcement vehicle;
 - (d) an Australian Border Force vehicle;
 - (e) an Airservices Australia vehicle;
 - (f) a vehicle at least 25 years old and fitted as a police vehicle or emergency vehicle if the vehicle—
 - (i) is used only for exhibition purposes; or
 - (ii) is part of a collection of former police vehicles or emergency vehicles;
 - (g) a vehicle used by the National Heavy Vehicle Regulator for enforcement of the Heavy Vehicle National Law;
 - (h) a motor vehicle fitted with an anti-theft alarm that can not be operated while the vehicle's ignition is on.
- (4) Also, a motor vehicle may be fitted with a device that emits a regular, intermittent sound while the vehicle is reversing or in reverse gear.
- (5) The device must not be louder than is necessary so the driver, and a person near the vehicle, can hear the device when it is operating.

- (6) A provision of a relevant ADR corresponding to subsection (2) applies to a motor vehicle as if the provision of the ADR did not refer to a bell.

34 Rear vision mirrors

- (1) At least 1 rear vision mirror must be fitted to—
 - (a) a car; and
 - (b) a motortrike with 2 front wheels; and
 - (c) a motorbike, or motortrike with 1 front wheel, built before July 1975.
- (2) At least 1 rear vision mirror must be fitted to each side of—
 - (a) a motor vehicle with a GVM of more than 3.5t; and
 - (b) a motorbike, or motortrike with 1 front wheel, built after June 1975.
- (3) A motor vehicle with a GVM of 3.5t or less, other than a motor vehicle mentioned in subsection (1) or (2), must be fitted with—
 - (a) at least 1 rear vision mirror on the right side of the vehicle; and
 - (b) at least 1 rear vision mirror on the left side of the vehicle or inside the vehicle.
- (4) A rear vision mirror fitted to a motor vehicle, as required under this section, must be fitted in a way that the vehicle's driver, in the normal driving position of the vehicle, can clearly see the road behind the vehicle and any vehicle following or overtaking the vehicle reflected in the mirror.
- (5) A rear vision mirror fitted to a motor vehicle with a GVM of more than 3.5t must not project more than 150mm past the overall width of the vehicle, measured in accordance with section 6.
- (6) However, the rear vision mirror may project not more than 230mm past the widest part of the vehicle or combination if it can fold to project not over 150mm past the overall width of the vehicle, measured in accordance with section 6.

35 Rear view mirrors—surfaces

- (1) A rear vision mirror required to be fitted to the side of a motor vehicle with a GVM of more than 3.5t must have a reflecting surface of at least 150cm².
- (2) The reflecting surface of the rear vision mirrors that are required to be fitted to a motorbike or moped must be—
 - (a) each of the same curvature; and
 - (b) if convex—part of a notional sphere with a radius of at least 1.2m.

36 Additional rear vision mirrors and surfaces

A motor vehicle may be fitted with additional rear vision mirrors or mirror surfaces that are flat, convex or a combination of flat and convex.

37 Automatic transmission

- (1) A motor vehicle fitted with an automatic transmission must have an engine starter mechanism that can not operate when the transmission control is in a position to drive the vehicle.
- (2) A vehicle built after 1975 that is fitted with an automatic transmission must have an indicator in the driver's compartment showing the transmission control position.
- (3) Subsections (1) and (2) do not apply to a motor vehicle with less than 4 wheels.

38 Diesel engines

A motor vehicle propelled by a diesel engine must be fitted with a device preventing the engine from being started accidentally or inadvertently.

39 Bonnet securing devices

- (1) A motor vehicle with a moveable body panel forward of the windscreen that covers an engine, luggage storage or battery compartment must have a device to secure the panel.
- (2) However, if the panel opens from the front in a way that partly or completely obstructs the driver's forward view through the windscreen, the panel must have primary and secondary devices to secure the panel.

40 Electrical wiring, components, connections and installations

- (1) The wiring of electrical equipment of a vehicle, other than the high tension ignition wiring, must—
 - (a) be supported at intervals of not more than 600mm, unless the vehicle is a pole-type trailer with an adjustable length pole or an extendible trailer; and
 - (b) be insulated at each of its joints; and
 - (c) be located where it can not—
 - (i) become overheated; or
 - (ii) contact moving parts; or
 - (iii) come near enough to the fuel system to be a fire hazard; and
 - (d) be protected from chafing.
- (2) The electrical components of a vehicle must be securely mounted.
- (3) The electrical connectors between motor vehicles and trailers for operation of the vehicle lights required under this schedule must comply with—
 - (a) for a connector fitted to the vehicle before 12 January 2014—AS 2513—1982 (Australian Standard for electrical connectors for trailer vehicles) as it was in force on 4 November 1995; or
 - (b) if paragraph (a) does not apply—at least 1 of the following standards—

-
- (i) AS 4177.5 (Australian Standard for caravan and light trailer towing components—electrical connectors);
 - (ii) AS 4735 (Australian Standard for heavy road vehicles—electrical connectors for articulated vehicles);
 - (iii) ISO 1185 (International Organization for Standardization standard for road vehicles—connectors for the electrical connection of towing and towed vehicles—7-pole connector type 24 N (normal) for vehicles with 24V nominal supply voltage);
 - (iv) SAE J560 (SAE International standard for primary and auxiliary seven conductor electrical connector for truck-trailer jumper cable).
- (4) For subsection (3)(b), a reference to a standard is a reference to the standard as in force under its alphanumeric designation when the connector is or was fitted to the vehicle.
- (5) A trailer must be equipped with an electrical conductor, independent of the trailer coupling, that provides a return path between the electrical circuits of the trailer and towing vehicle.
- (6) In this section—

ISO means a standard published by the International Organization for Standardization.

SAE means a standard published by SAE International.

41 Television receivers and visual display units

- (1) A television receiver or visual display unit must not be installed in a vehicle so any part of the image on the screen is visible to the driver from the normal driving position of the vehicle.
- (2) However, subsection (1) does not apply to—
- (a) a television receiver or visual display unit that can not be operated when a vehicle is moving; or

- (b) a driver's aid in a vehicle; or

Examples—

- closed-circuit television security cameras
- dispatch systems
- navigational or intelligent highway and vehicle system equipment
- rearview screens
- ticket-issuing machines
- vehicle monitoring devices

- (c) a destination sign in a bus.

- (3) A television receiver or visual display unit, and its associated equipment, in a vehicle must be securely mounted in a position that—

- (a) does not obscure the driver's view of the road; and
- (b) does not impede the movement of a person in the vehicle.

42 Requirement for windscreen to be fitted

If a motor vehicle, other than a motorbike, motortrike or moped, is designed or manufactured to have a windscreen, the motor vehicle must be fitted with a windscreen.

43 Windscreens and windows

- (1) Transparent material used in a windscreen, window or interior partition of a motor vehicle must be of approved material if—

- (a) the vehicle was built after June 1953; or
- (b) the material was first fitted to the vehicle after June 1953.

- (2) In this section—

ANSI means a standard approved and published by the American National Standards Institute.

approved material means material with the same characteristics as the material mentioned in any of the following standards—

- AS R1—1965 (Australian Standard for safety glass for land transport)
- AS R1—1968 (Australian Standard for safety glass for land transport)
- AS 2080—1977 (Australian Standard for safety glass for vehicles)
- BS 857:1967 (British Standard for specification for safety glass for land transport)
- BS 5282:1975 (British Standard for specification for road vehicle safety glass)
- BS AU178:1980 (British Standard for specification for road vehicle safety glass)
- JIS R 3211—1979 (Japanese Industrial Standard for safety glasses for road vehicles)
- ANSI Z26.1—1980 (American National Standards Institute standard for safety code for safety glazing materials for glazing motor vehicles operating on land highways).

JIS means a Japanese Industrial Standard published by the Japanese Standards Association.

transparent material does not include any coating added to the windscreen, window or partition after its manufacture.

44 Window tinting

- (1) Glazing used in a windscreen of a motor vehicle must have a luminous transmittance of at least 70%.
- (2) Glazing used in a windscreen of a motor vehicle must not be coated in a way that reduces its luminous transmittance.
- (3) However, subsections (1) and (2) do not apply to the greater of the following areas of a windscreen—

- (a) the area above the highest point of the windscreen that is swept by a windscreen wiper;
 - (b) the upper 10% of the windscreen.
- (4) Glazing used in a window or interior partition of a motor vehicle must have a luminous transmittance of at least 70%.
- (5) Glazing used in a window or interior partition of a motor vehicle, other than rear glazing, may be coated to achieve a luminous transmittance of not less than 35%.
- (6) If at least 1 rear vision mirror is fitted to each side of a motor vehicle, the motor vehicle's rear glazing may be coated to achieve a luminous transmittance of at least 20%.
- (7) However, a motor vehicle's rear glazing may be coated to achieve a luminous transmittance of 0% or more if—
 - (a) at least 1 rear vision mirror is fitted to each side of the vehicle; and
 - (b) the vehicle is a goods vehicle; and
 - (c) the vehicle has—
 - (i) at least 4 wheels; or
 - (ii) at least 3 wheels and a GVM of more than 1t.
- (8) The luminous transmittance requirements mentioned in subsections (5), (6) and (7) apply to a motor vehicle instead of the corresponding requirements stated in a second edition ADR or third edition ADR.
- (9) Glazing used in a windscreen, window or interior partition of a motor vehicle that has been coated to reduce its luminous transmittance must not have a reflectance of more than 10%.
- (10) In this section—
 - glazing*—
 - (a) means material that may be used in a windscreen, window or interior partition of a motor vehicle through which the vehicle's driver can see the road; but
 - (b) does not include a coating added after manufacture of the material.

luminous transmittance, for glazing or a coating on glazing, means the amount of light that can pass through the glazing as a percentage of the amount of light that would be transmitted if the glazing or coating were absent.

rear glazing, for a motor vehicle, means glazing used in a window or interior partition of the motor vehicle located behind the normal driving position of the vehicle.

45 Windscreen wipers and washers

- (1) A motor vehicle with 3 or more wheels that is fitted with a windscreen must be fitted with at least 1 windscreen wiper unless the vehicle's driver, in the normal driving position of the vehicle, can obtain an adequate view of the road ahead of the vehicle without looking through the windscreen.
- (2) At least 1 windscreen wiper fitted to the motor vehicle must—
 - (a) be able to remove moisture from the part of the windscreen in front of the driver to allow the driver an adequate view of the road ahead of the motor vehicle when the windscreen is wet; and
 - (b) be able to be operated from the normal driving position of the vehicle; and
 - (c) for a motor vehicle built after 1934—continue to operate until the wiper is switched off; and
 - (d) for a motor vehicle built after 1959 with the driving position nearer to one side of the vehicle than the other—
 - (i) be able to remove moisture from the part of the windscreen in front of the driver, and a corresponding part of the windscreen on the other side of the centre of the motor vehicle, to allow the driver an adequate view of the road ahead of the motor vehicle when the windscreen is wet; and
 - (ii) if the windscreen wipers are operated by engine manifold vacuum—be provided with a vacuum reservoir or pump to maintain the efficient

operation of the wiper or wipers while the vehicle is in motion.

- (3) The windscreen washer must be able to be operated by the driver from the normal driving position of the vehicle.

46 Wheels and tyres—size and capacity

- (1) The wheels and tyres fitted to an axle of a vehicle must be of sufficient size and capacity to carry the part of the vehicle's loaded mass transmitted to the ground through the axle.
- (2) For subsection (1), the size and capacity of a pneumatic tyre to be fitted to a vehicle must be decided using a cold inflation pressure that is not more than the lesser of—
 - (a) the pressure recommended by the tyre manufacturer; and
 - (b) a pressure of—
 - (i) for a radial ply tyre—825kPa; or
 - (ii) for another tyre—700kPa.
- (3) In this section—

radial ply tyre means a radial ply tyre within the meaning of ADR (definitions and vehicle categories).

47 Pneumatic tyres for particular vehicles

A vehicle built after 1932 must be fitted with pneumatic tyres.

48 Pneumatic tyres—carcass construction

- (1) The pneumatic tyres fitted to an axle of a vehicle—
 - (a) must not have different carcass construction; but
 - (b) may have different cord materials and a different number of plies.
- (3) However, subsection (1) does not apply to a tyre being used in an emergency as a temporary replacement for a tyre complying with the subsection.

49 Tyres—defects

A tyre fitted to a vehicle must be free of any apparent defect that could make the vehicle unsafe.

50 Tyres—manufacturer’s rating

- (1) This section applies to a motor vehicle if the vehicle—
 - (a) has 4 or more wheels; and
 - (b) was built after 1972.
- (2) However, this section does not apply to a tyre fitted to a motor vehicle if the tyre—
 - (a) is recommended by the builder of the vehicle as suitable for limited use on the vehicle in special circumstances at a speed less than the speed applying to the tyre under subsection (3); or
 - (b) is being used in an emergency as a temporary replacement for a tyre complying with subsection (3).
- (3) A tyre fitted to the motor vehicle must, when first manufactured, have been rated by the tyre manufacturer as suitable for road use at the lesser of—
 - (a) a speed of at least—
 - (i) for a car with special features for off-road use—140km/h; or
Example—
a four-wheel drive vehicle
 - (ii) for another car—180 km/h; or
 - (iii) for another motor vehicle—120km/h; and
 - (b) the vehicle’s top speed.
- (4) This section applies to a vehicle instead of the tyre speed category requirements stated in the relevant ADR.

51 Retreads

- (1) A tyre that is retreaded before the retread compliance date must not be used on a motor vehicle unless—
 - (a) either of the following Australian Standards apply to the tyre—
 - (i) AS 1973—1976 (Australian Standard for retreaded pneumatic passenger car tyres);
 - (ii) AS 1973—1985 (Australian Standard for retreaded pneumatic passenger car and light truck tyres); and
 - (b) the tyre is retreaded after publication of the Australian Standard; and
 - (c) the tyre is retreaded in accordance with—
 - (i) AS 1973—1976 (Australian Standard for retreaded pneumatic passenger car tyres); or
 - (ii) AS 1973—1985 (Australian Standard for retreaded pneumatic passenger car and light truck tyres); or
 - (iii) AS 1973—1993 (Australian Standard for pneumatic tyres—passenger car, light truck, and truck/bus—retreading and repair processes).
- (2) A tyre that is retreaded after the retread compliance date must not be used on a vehicle unless—
 - (a) AS 1973—1993 (Australian Standard for pneumatic tyres—passenger car, light truck, and truck/bus—retreading and repair processes) applies to the tyre; and
 - (b) the tyre is retreaded in accordance with the Australian Standard.
- (3) In this section—

retread compliance date means 1 September 2010.

52 Tyre tread

- (1) A tyre fitted to a motor vehicle must not have cleats or other gripping devices that could damage road surfaces.

-
- (2) A tyre fitted to the motor vehicle must, other than at tread wear indicators, have a tread pattern of at least 1.5mm deep in all principal grooves on the tyre in a band that runs continuously—
- (a) across the tyre width normally coming into contact with the road; and
 - (b) around the whole circumference of the tyre.
- (3) A vehicle must not be fitted with a tyre that has been treated by recutting or regrooving the tread rubber, unless the tyre was—
- (a) constructed with an extra thickness of rubber designed for recutting or regrooving; and
 - (b) labelled to indicate the construction.

- (4) In this section—

principal grooves, for a tyre, means wide grooves, other than secondary grooves—

- (a) usually positioned—
 - (i) in the central zone of the tyre’s tread; or
 - (ii) running across the tyre’s tread; and
- (b) in which tread wear indicators are usually located.

secondary grooves, for a tyre, means shallow grooves in the tyre’s tread that may disappear through wear of the tyre.

tread wear indicators, for a tyre, means projections within a groove of the tyre indicating the degree of wear of the tyre’s tread.

Division 2 Additional requirements for motorbikes

53 Steering gear and handlebars

- (1) The handlebars on a motorbike, other than a motorbike in vehicle category LC or LD, must extend at least 250mm, but

not more than 450mm, on each side of the centre line of the motorbike.

- (2) The handlebars on a motorbike in vehicle category LC or LD must extend at least 250mm, but not more than 550mm, on each side of the centre line of the motorbike.
- (3) In taking a measurement for subsection (1), mirrors and lights mounted on the handlebars of the motorbike are disregarded.
- (4) The lowest part of the hand grip on the handlebars must not be higher than—
 - (a) for a motorbike built before 1 July 1988—380mm above the attachment point of the handlebars to the motorbike; or
 - (b) for a motorbike built on or after 1 July 1988—380mm above the lowest part of the upper surface of the driver's seat.
- (5) Hand grips on the handle bars must be fitted symmetrically.
- (6) If a motorbike has the head stem as the steering pivot point, the horizontal distance from the midpoint between the head stem bearings to the centre of the front wheel must not be more than 550mm.

Example—

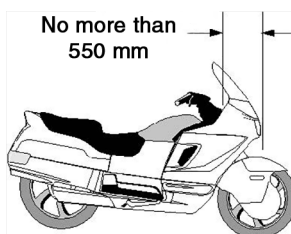

- (7) In this section—

vehicle category LC or LD means the vehicle category LC or LD shown for motor cycles under the ADR (definitions and vehicle categories).

54 Foot rests

A motorbike must be fitted with foot rests for the driver and any passenger for whom a seating position is provided.

55 Chain guards

- (1) If the engine power of a motorbike is transmitted to the rear wheel by a chain, the driver and any passenger must be protected from the front sprocket and at least the upper part of the chain by—
 - (a) the frame or equipment of the motorbike; or
 - (b) a chain guard.
- (2) A chain guard must cover the chain to a point—
 - (a) at least 300mm to the rear of the rearmost foot rest of the motorbike; or
 - (b) above the centre of the rear drive sprocket of the motorbike.

Part 5 Vehicle marking

56 Engine number and vehicle identification number

- (1) A motor vehicle must have an engine number clearly stamped, embossed or otherwise permanently marked on its engine.
- (2) A motor vehicle built after 1930 must have the engine number on its engine block or the main component of its engine.
- (3) A vehicle must have a VIN clearly stamped, embossed or otherwise permanently marked on a substantial part of its frame or chassis.
- (4) An engine number or VIN must be located where a person can read it easily and without having to use tools to remove a part of the vehicle that would otherwise obstruct the person's view of the number.

57 White or silver band on particular vehicles

- (1) This section applies to a vehicle that—
 - (a) is at least 2.2m wide; and
 - (b) has a body with a vertical measurement of less than 300mm at the rear, measured from the lowest point of the body above ground level to the highest point; and
 - (c) is not fitted with rear marking plates or conspicuity markings in accordance with section 115.
- (2) The vehicle must have a white or silver band at least 75mm high across the full width of the rearmost part of the body of the vehicle.

Part 6 Vehicle configuration and dimensions

Division 1 Axles

58 Axle configuration

- (1) A motor vehicle must have only—
 - (a) 1 axle group or single axle towards the front of the vehicle; and
 - (b) 1 axle group or single axle towards the rear of the vehicle.
- (2) A trailer must have only—
 - (a) 1 axle group or single axle; or
 - (b) 2 axle groups, 2 single axles, or 1 axle group and 1 single axle in the following configuration—
 - (i) 1 axle group or single axle towards the front of the vehicle, with all the wheels on the axle group or single axle connected to the steering mechanism for that part of the trailer;

- (ii) 1 axle group or single axle towards the rear of the vehicle.
- (3) A semitrailer that is extendible or fitted with sliding axles must—
 - (a) have a securing device that—
 - (i) can securely fix the extendible part or sliding axles to the rest of the semitrailer in any position of adjustment provided; and
 - (ii) for a device mounted on the chassis of the semitrailer—is located in a position that can prevent accidental or inadvertent release of the device; and
 - (iii) is fitted with a visible or audible warning system to indicate to a person standing beside the semitrailer that the device is not engaged; and
 - (iv) for a device that uses air from the brake system—is fitted with a way of preventing air loss from the air brake supply if the device fails in a way allowing air to escape; and
 - (v) is held in the applied position by direct mechanical action without the intervention of an electric, hydraulic or pneumatic device; and
 - (b) be built so the adjustable parts of the semitrailer remain connected if the securing device fails.

59 Retractable axles

- (1) A reference in this schedule to an axle is taken to include a reference to a retractable axle only when the retractable axle is in the lowered position.
- (2) In this section—

retractable axle means an axle with a means of adjustment enabling the axle to be raised or lowered relative to the other axles in the axle group.

Division 2 Dimension requirements

59A Light vehicle includes load on vehicle

In this division, a reference to a light vehicle includes a load on the vehicle.

Note—

This provision is an additional Queensland provision.

60 Meaning of *rear overhang* and *rear overhang line*

- (1) The *rear overhang* of a vehicle is the distance between the rear of the vehicle and the rear overhang line of the vehicle.
- (2) For a vehicle with a single axle at the rear, the *rear overhang line* is a line running along the centre line of the axle.
- (3) For a vehicle with an axle group at the rear of the vehicle consisting of 2 axles, of which 1 of the axles is fitted with twice the number of tyres as the other axle, the *rear overhang line* is a line running parallel to the axles that is—
 - (a) closer to the axle fitted with the greater number of tyres; and
 - (b) located one-third of the distance between the 2 axles.
- (4) For a vehicle with an axle group at the rear of the vehicle, other than an axle group mentioned in subsection (2) or (3), the *rear overhang line* is a line running parallel to the axles along the centre line of the axle group.
- (5) For subsection (3) or (4), if an axle group includes at least 1 steerable axle, the axle is disregarded unless all axles in the group are steerable axles.

Example of the rear overhang and rear overhang line for a motor vehicle—

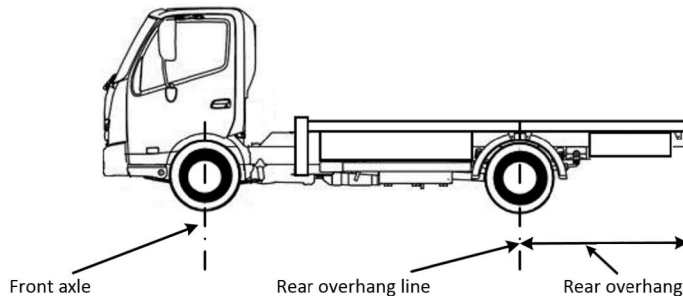

Example of the rear overhang and rear overhang line for a vehicle with a tri-axle group at the rear—

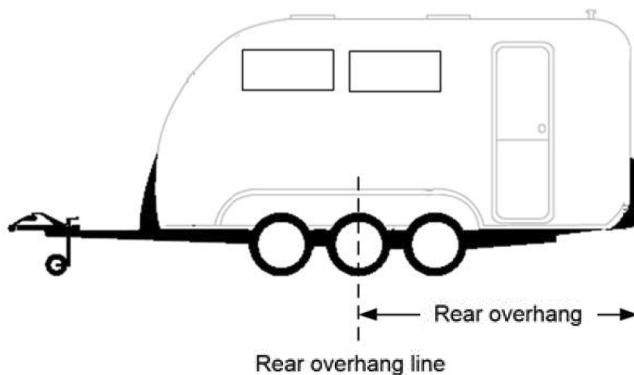

Example of the rear overhang and rear overhang line for a semitrailer—

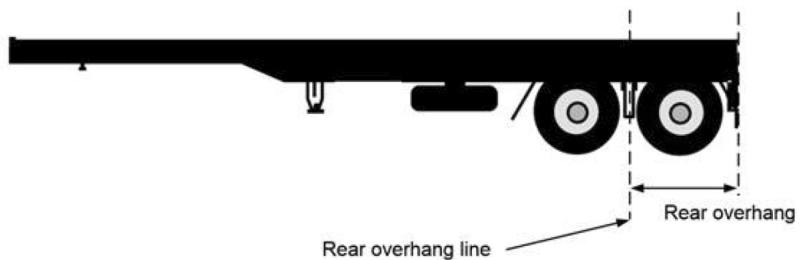

61 Length of single motor vehicles

A motor vehicle must not be more than 12.5m long.

62 Length of single trailers

- (1) For a semitrailer or a dog trailer—
 - (a) the distance between the point of articulation at the front of the trailer and the trailer's rear overhang line must not be more than 9.5m; and
 - (b) the distance between the point of articulation at the front of the trailer and the rear of the trailer must not be more than 12.3m.
- (2) A projection forward of the point of articulation at the front of a semitrailer must be contained within a radius of 1.9m from the point of articulation.

Example of the maximum dimensions of a semitrailer—

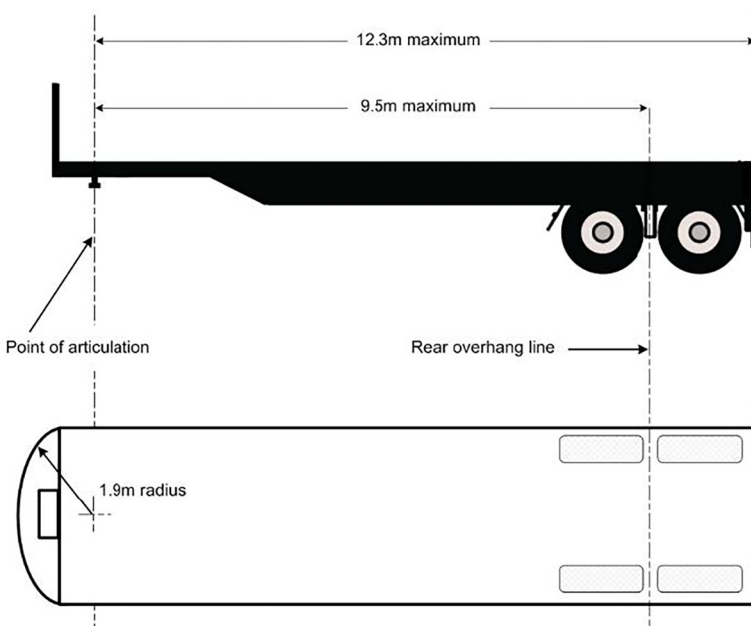

63 Length of combinations

A combination must not be more than 19m long.

64 Rear overhang

- (1) The rear overhang of a semitrailer, or dog trailer consisting of a semitrailer and converter dolly, must not exceed the lesser of—
 - (a) 60% of the distance between the point of articulation at the front of the trailer and the trailer's rear overhang line; or
 - (b) 3.7m.
- (2) The rear overhang of a trailer with only 1 axle group or a single axle, other than a semitrailer, must not exceed the lesser of—
 - (a) the length of the load-carrying area, or body, ahead of the rear overhang line of the trailer; or
 - (b) 3.7m.
- (3) The rear overhang of a vehicle, other than a vehicle mentioned in subsection (1) or (2), must not exceed the lesser of—
 - (a) 60% of the distance between the centre line of the front axle and the rear overhang line of the vehicle; or
 - (b) 3.7m.

65 Length—trailer drawbar

- (1) For a dog trailer, the distance between the pivot point of the coupling on a drawbar of the trailer and the centre line of the trailer's front axle group or single axle must not be more than 5m.

Example showing the points on a dog trailer for measuring the length of a drawbar on the trailer—

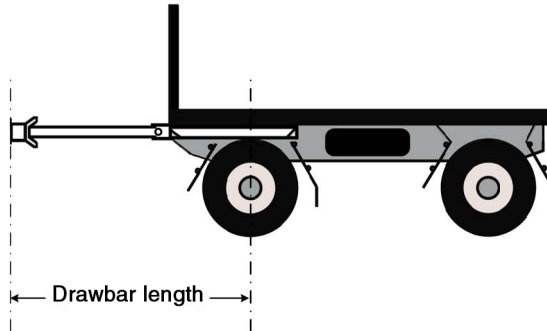

- (2) For a trailer with 1 axle group or a single axle, other than a semitrailer, the distance between the pivot point of the coupling on a drawbar of the trailer and the centre line of the trailer's axle group or single axle must not be more than 8.5m.

66 Width

A vehicle must not be more than 2.5m wide.

67 Height

A vehicle must not be more than 4.3m high.

68 Ground clearance

- (1) A motor vehicle or combination must have a ground clearance of—
- (a) at least 100mm at any point within 1m of an axle of the vehicle or combination; and
 - (b) at the midpoint between adjacent axles of the vehicle or combination—at least one-thirtieth of the distance between the centre lines of the axles; and
 - (c) at any other point—at least the distance that allows the vehicle or combination to pass over a peak in the road, with a gradient of 1:15 on either side of the peak, if the wheels of 1 axle of the vehicle or combination are on the

slope on 1 side of the peak and the wheels of the next axle are the slope on the other side.

Example of ground clearance at the midpoint between adjacent axles—

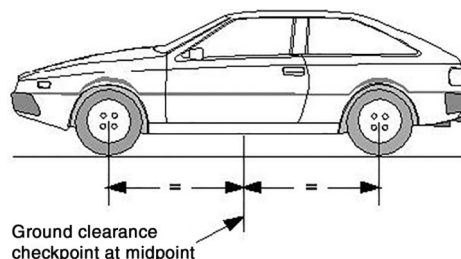

Example of ground clearance over a peak in the road—

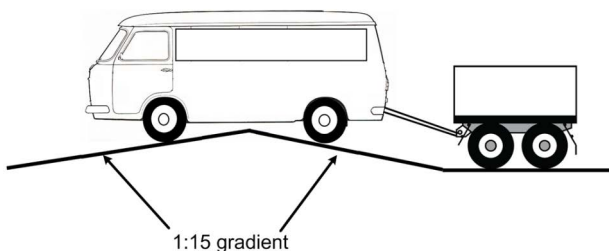

- (2) This section does not apply to—
- (a) a motor vehicle with fewer than 4 wheels; or
 - (b) a combination including a motor vehicle with fewer than 4 wheels.
- (3) In this section—

ground clearance, of a vehicle, means the minimum distance to the ground from a point on the underside of the vehicle, other than a point on a tyre, wheel, wheel hub, brake backing plate or flexible mudguard or mudflap of the vehicle.

Part 7 **Lights and reflectors**

Division 1 **Application of particular requirements**

69 **Part does not apply to particular vehicles**

- (1) This part does not apply to a vehicle built before 1931 used only in the daylight.
- (2) This part does not apply to a vehicle built before 1946 used mainly for exhibition purposes.

70 **Particular requirements apply only at night**

The requirements of this part for a light, other than a brake light or direction indicator light, to be visible over a stated distance apply only at night.

Division 2 **General requirements for lights**

71 **Prevention of glare**

A light, other than a high-beam headlight, fitted to a vehicle must be built and adjusted to provide the necessary amount of light without dazzling the driver of another vehicle approaching, or being approached by, the vehicle.

72 **Pairs of lights**

- (1) If, under this schedule, lights are required to be fitted to a vehicle in a pair—
 - (a) each light in the pair must be fitted on each side of the longitudinal axis of the vehicle; and
 - (b) the centre of each light in the pair must be the same distance from the longitudinal axis of the vehicle; and

- (c) the centre of each light in the pair must be at the same height above ground level; and
 - (d) each light in the pair must project approximately the same amount of light of the same colour.
- (2) Subsection (1) applies to a motorbike with a sidecar as if the motorbike did not have a sidecar.

Division 3 Headlights

73 Headlights to be fitted to vehicles

- (1) A motor vehicle must be fitted with—
- (a) for a moped, motorbike, or motortrike with 1 front wheel—1 low-beam headlight; or
 - (b) for a vehicle with 4 or more wheels or a motortrike with 2 front wheels, other than a moped—a pair of low-beam headlights.
- (2) If a motor vehicle built after 1934 can travel at more than 60km/h—
- (a) each low-beam headlight mentioned in subsection (1) must be able to work in the high-beam position; or
 - (b) the vehicle must be fitted with—
 - (i) for a vehicle required to have 1 low-beam headlight—1 headlight that can work in the high-beam position; or
 - (ii) a pair of headlights that can work in the high-beam position.
- (3) A motorbike may be equipped with a headlight modulation system that—
- (a) varies the brightness of its high-beam headlight or low-beam headlight, but not both, at a rate of at least 200, but not more than 280, flashes a minute; and
 - (b) is designed to operate only in the daylight.

- (4) Up to 4 additional headlights may be fitted to a motor vehicle with 4 or more wheels, a motorbike or a motortrike.
- (5) An additional headlight fitted to a vehicle must be fitted so it faces forward and is symmetrical in relation to the centre of the front of the vehicle.

Note—

See also section 72 for further requirements applying when lights are required to be fitted to a vehicle in a pair.

Example of the position of additional headlights fitted to a vehicle—

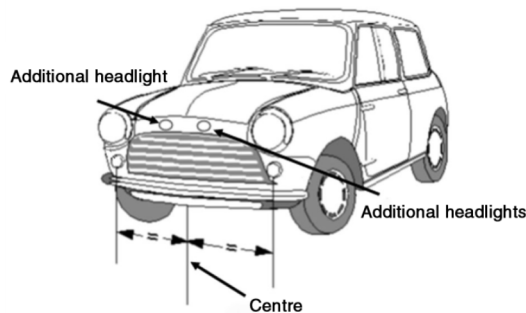

74 How headlights are to be fitted

- (1) The centre of each low-beam headlight fitted as a pair on a motor vehicle with 4 or more wheels must be at least 600mm apart.
- (2) However, subsection (1) does not apply to a motor vehicle built before 1970 if the centres of its low-beam headlights—
 - (a) were less than 600mm apart when the vehicle was built; and
 - (b) are not nearer than they were when the vehicle was built.
- (3) Each low-beam headlight of a pair of headlights fitted to a motortrike with 2 front wheels, other than a moped, must not be more than 400mm from the nearer side of the motortrike.
- (4) The centre of a low-beam headlight fitted to a motor vehicle built after June 1953 must be—
 - (a) at least 500mm above ground level; and

- (b) not more than 1.4m above ground level.

75 How single headlights are to be fitted

- (1) A motorbike or motortrike fitted with a single headlight must have the light fitted in the centre of the motorbike or motortrike.
- (2) Subsection (1) applies to a motorbike with sidecar as if the motorbike did not have a sidecar.

76 Section 76 not used

See note to section 1.

77 Performance of headlights

- (1) When on, a headlight or additional headlight fitted to a vehicle must—
 - (a) show only white light; and
 - (b) project its main beam of light ahead of the vehicle.
- (2) A headlight must be fitted to a vehicle in a way that the light from the headlight does not reflect off the vehicle into the eyes of the driver from the normal driving position of the vehicle.

78 Effective range of headlights

- (1) This section applies to a headlight fitted to a motor vehicle that is on at night.
- (2) A low-beam headlight must illuminate the road ahead of the vehicle for at least 25m.
- (3) A high-beam headlight must illuminate the road ahead of the vehicle for at least 50m.
- (4) However, a low-beam headlight fitted to a motor vehicle built before 1931, or a moped, need only illuminate the road ahead of the vehicle for at least 12m.

79 Changing headlights from high-beam to low-beam position

- (1) A motor vehicle built after 1934 that can travel at more than 60km/h must be fitted with—
 - (a) a dipping device enabling the driver from the normal driving position of the vehicle—
 - (i) to change the headlights from the high-beam position to the low-beam position; or
 - (ii) to simultaneously switch off a high-beam headlight and switch on a low-beam headlight; and
 - (b) for a vehicle built after June 1953—a device to indicate to the driver from the normal driving position of the vehicle that the headlights are in the high-beam position.
- (2) A headlight fitted to a motor vehicle without a dipping device mentioned in subsection (1)(a) must operate in the low-beam position.
- (3) When a headlight fitted to a motor vehicle is switched to the low-beam position, any other headlight on the vehicle must operate only in the low-beam position or be off.

Division 4 Parking lights

80 Parking lights

- (1) A motor vehicle built after June 1953 must be fitted with—
 - (a) for a motor vehicle with 4 or more wheels or a motortrike with 2 front wheels, other than a moped—a pair of parking lights; or
 - (b) for a motorbike with a sidecar, or a motortrike with 1 front wheel, other than a moped—at least 1 parking light.

Note—

See also section 72 for further requirements applying when lights are required to be fitted to a vehicle in a pair.

Example of the position of a pair of parking lights fitted to a motor vehicle with 4 wheels—

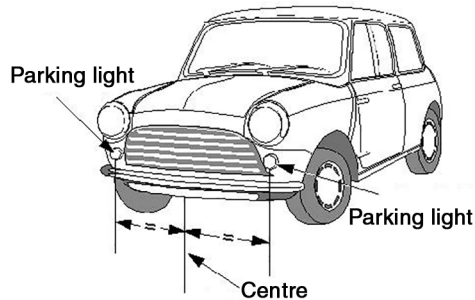

- (2) A pair of parking lights fitted to a motor vehicle with 4 or more wheels must be fitted with the centre of each light—
 - (a) at least 600mm from the centre of the other light; and
 - (b) not more than 510mm from the nearer side of the vehicle.
- (3) However, a pair of parking lights fitted to a motor vehicle less than 1,300mm wide may be fitted with the centre of each light not less than 400mm from the centre of the other light.
- (4) A parking light fitted to a motortrike with 2 front wheels must not be more than 400mm from the nearer side of the vehicle.
- (5) A parking light fitted to a motorbike with a sidecar must be fitted not more than 150mm from the side of the sidecar furthest from the motorbike.
- (6) When on, a parking light fitted to a motor vehicle must—
 - (a) show a white or yellow light visible at least 200m from the front of the vehicle; and
 - (b) not use more than 7W.
- (7) A parking light fitted to a motor vehicle built after 1969 must be wired so the parking light is on when a headlight on the vehicle is on.
- (8) A parking light fitted to a sidecar of a motorbike must be wired to operate when a headlight, tail light or parking light on the motorbike is on.

Division 5 Daytime running lights

81 Daytime running lights

- (1) A pair of daytime running lights may be fitted to a motor vehicle.

Note—

See also section 72 for further requirements applying when lights are required to be fitted to a vehicle in a pair.

Example of the position of a pair of daytime running lights fitted to a motor vehicle with 4 wheels—

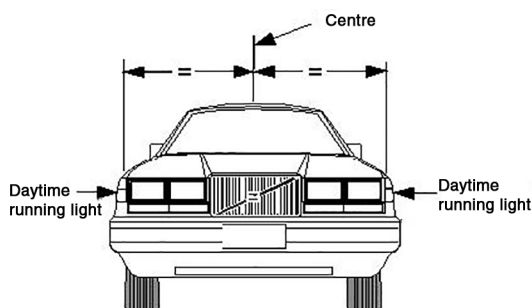

- (2) A pair of daytime running lights fitted to a vehicle with 4 or more wheels must be fitted with the centre of each light—
- at least 600mm from the centre of the other light; and
 - not more than 510mm from the nearer side of the vehicle.
- (3) However, a pair of daytime running lights fitted to a motor vehicle less than 1,300mm wide may be fitted with the centre of each light not less than 400mm from the centre of the other light.
- (4) When on, a daytime running light fitted to a motor vehicle must—
- show a white or yellow light visible from the front of the vehicle; and
 - not use more than 25W.

Note—

The third edition ADRs only allow white daytime running lights.

- (5) Daytime running lights fitted to a motor vehicle must be wired so they are off when a headlight, other than a headlight being used as a flashing signal, is on.

Division 6 Tail lights

82 Tail lights generally

- (1) A vehicle must have at least 1 tail light fitted on or towards the rear of the vehicle.
- (2) A motortrike with 2 rear wheels, or a motor vehicle with 4 or more wheels, built after 1959 must have at least 1 tail light fitted on, or towards each side of, the rear of the vehicle.
- (3) A trailer built after June 1973 must have at least 1 tail light fitted on, or towards each side of, the rear of the vehicle.
- (4) The centre of a tail light mentioned in subsection (1), (2) or (3) must not be more than—
 - (a) 1.5m above ground level; or
 - (b) if it is not practicable to fit the light as required under paragraph (a)—2.1m above ground level.
- (5) A vehicle may be fitted with 1 or more additional tail lights at any height above ground level.

83 Pattern of fitting tail lights

- (1) If only 1 tail light is fitted to a vehicle, it must be fitted in the centre, or to the right of the centre, of the vehicle's rear.
- (2) Subsection (1) applies to a motorbike with a sidecar as if the motorbike did not have a sidecar.
- (3) If 2 or more tail lights are fitted to a vehicle, at least 2 of the tail lights must be fitted as a pair.

Note—

See also section 72 for further requirements applying when lights are required to be fitted to a vehicle in a pair.

Example of the position of a pair of tail lights fitted to a vehicle—

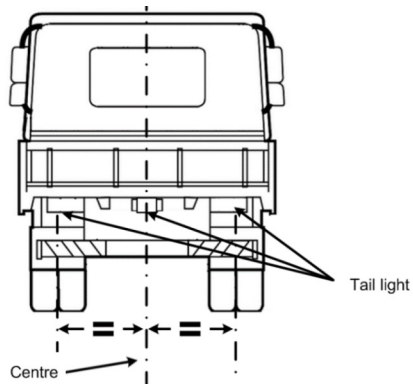

- (4) Tail lights fitted to a vehicle in accordance with this division may also serve as rear clearance lights if the tail lights are fitted to the vehicle in accordance with section 89(3).

84 Performance of tail lights

- (1) When on, a tail light fitted to a vehicle must—
- (a) show a red light visible at least 200m from the rear of the vehicle; and
 - (b) not use more than 7W.
- (2) A tail light fitted to a street rod vehicle may incorporate a blue lens not more than 20mm in diameter.

85 Wiring of tail lights

A tail light fitted to a motor vehicle must be wired to come on, and stay on, when a parking light or headlight on the vehicle is on, unless an external switch is fitted to operate the tail light.

Division 7 **Number plate lights**

86 **Number plate lights**

- (1) At least 1 number plate light must be fitted to the rear of a vehicle.
- (2) When on, a number plate light must illuminate a number plate fitted to the rear of the vehicle with white light, so the characters on the number plate can be read at night at least 20m from the rear of the vehicle.
- (3) A number plate light—
 - (a) may be combined with another light; and
 - (b) must not project white light to the rear of the vehicle other than by reflection; and
 - (c) must not obscure the characters of the number plate; and
 - (d) must be wired to come on, and stay on, when a parking light, headlight or tail light on the vehicle is on.

Division 8 **Clearance lights**

87 **Front clearance lights**

- (1) Front clearance lights may only be fitted to a vehicle that is at least 1.8m wide.
- (2) A pair of front clearance lights must be fitted to a motor vehicle that is at least 2.2m wide or a prime mover.
- (3) The centre of a front clearance light must be fitted—
 - (a) not more than 400mm from the nearer side of the vehicle; and
 - (b) for a vehicle built after June 1953—
 - (i) at least 750mm higher than the centre of any low-beam headlight fitted to the vehicle; or
 - (ii) not lower than the top of the windscreen.

- (4) However, a front clearance light may be mounted on an external rear vision mirror or a mirror support if, when the mirror is correctly adjusted, no part of the lens of the light is visible to the driver from the normal driving position of the vehicle.
- (5) When on, a front clearance light must—
 - (a) show a white or yellow light visible at least 200m from the front of the vehicle; and
 - (b) not use more than 7W.

88 External cabin lights

- (1) A motor vehicle fitted with front clearance lights may have additional forward-facing lights fitted to, or above, the roof of its cabin.
- (2) The forward-facing lights must be spaced evenly between the front clearance lights, with the centres of the lights at least 120mm apart.
- (3) When on, a forward-facing light fitted to a motor vehicle must—
 - (a) show a white or yellow light; and
 - (b) not use more than 7W.

89 Rear clearance lights

- (1) Rear clearance lights may only be fitted to a vehicle that is at least 1.8m wide.
- (2) A pair of rear clearance lights must be fitted to the rear of a vehicle that is at least 2.2m wide.
- (3) The centre of a rear clearance light must be fitted—
 - (a) not more than 400mm from the nearer side of the vehicle; and
 - (b) if practicable, at least 600mm above ground level.
- (4) When on, a rear clearance light must—

- (a) show a red light visible at least 200m from the rear of the vehicle; and
- (b) not use more than 7W.

Division 9 Side marker lights

90 Vehicles required to have side marker lights

- (1) A pair of side marker lights must be fitted towards the rear of the sides of a motor vehicle that is more than 7.5m long and at least 2.2m wide.
- (2) A pole-type trailer or a motor vehicle built to tow a pole-type trailer, each with at least 1 cross-bar or bolster, must have 1 side marker light fitted to each side of the back of the trailer, cross-bar or bolster.
- (3) Also, a pole-type trailer with 2 or more cross-bars or bolsters may have 1 side marker light fitted to each side of the front cross-bar or bolster.
- (4) At least 2 side marker lights must be fitted to each side of—
 - (a) a trailer, other than a pole-type trailer, that is at least 2.2m wide and not more than 7.5m long; or
 - (b) a semitrailer that is not more than 7.5m long.
- (5) At least 3 side marker lights must be fitted to each side of—
 - (a) a trailer, other than a pole-type trailer, that is at least 2.2m wide and more than 7.5m long; or
 - (b) a semitrailer that is more than 7.5m long.

91 Location of side marker lights

- (1) The centre of a side marker light must not be more than 150mm from the nearer side of the vehicle.
- (2) A front side marker light fitted to a motor vehicle must be fitted—
 - (a) towards the front of the side of the vehicle; and

- (b) with no part of the lens visible to the vehicle's driver.
- (3) The centre of a front side marker light fitted to a trailer must be—
 - (a) within 300mm of the front of the side of the trailer; or
 - (b) if the construction of the trailer makes it impracticable to comply with paragraph (a)—as near as practicable to the front of the side of the trailer.
- (4) The centre of a rear side marker light fitted to a vehicle must be—
 - (a) within 300mm of the rear of the side of the vehicle; or
 - (b) if the construction of the vehicle makes it impracticable to comply with paragraph (a)—as near as practicable to the rear of the side of the vehicle.
- (5) Side marker lights fitted to a vehicle must, as far as practicable, be evenly spaced along the side of the vehicle.
- (6) Subsections (2) to (5) do not apply to a side marker light fitted to a cross-bar or bolster of a pole-type trailer.
- (7) If complying with subsections (3) and (4) would result in front and rear side marker lights being less than 2.5m apart, only the side marker lights nearest to the rear of a vehicle need be fitted.
- (8) A side marker light fitted to a vehicle must be fitted—
 - (a) with its centre at least 600mm above ground level; and
 - (b) with its centre not more than—
 - (i) 1.5m above ground level; or
 - (ii) if it is not practicable to fit it in accordance with subparagraph (i)—2.1m above ground level; and
 - (c) as far as practicable, in a row of side marker lights along the side of the vehicle.
- (9) Subsection (8)(b) does not apply to a side marker light that is not required to be fitted to the vehicle by section 90.

92 Performance of side marker lights

- (1) When on, a side marker light fitted to a vehicle must—
 - (a) show a light visible at least 200m from the vehicle; and
 - (b) not use more than 7W.
- (2) Also, when on, a side marker light fitted to a vehicle must show—
 - (a) yellow light to the front of the vehicle; and
 - (b) light to the rear of the vehicle that is—
 - (i) for a light that also operates as a rear light or reflector—red; and
 - (ii) otherwise—red or yellow.
- (3) However, if a pole-type trailer with 2 or more cross-bars or 2 or more bolsters has the side marker lights permitted under section 90(3)—
 - (a) the side marker lights fitted to the front cross-bar or bolster may comply with subsection (2)(a) only; and
 - (b) the side marker lights fitted to the back cross-bar or bolster may comply with subsection (2)(b) only.

93 Side marker lights and rear clearance lights

The side marker light nearest to the rear of a vehicle may be a rear clearance light for section 89.

Division 10 Brake lights

94 Fitting brake lights

- (1) A brake light must be fitted to the rear of a vehicle built after 1934.
- (2) A pair of brake lights must be fitted to the rear of—
 - (a) a motor vehicle with 4 or more wheels built after 1959; and

- (b) a motortrike with 2 rear wheels built after 1959; and
- (c) a trailer built after June 1973.

Note—

See also section 72 for further requirements applying when lights are required to be fitted to a vehicle in a pair.

Example of the position of a pair of brake lights fitted to a motor vehicle with 4 wheels—

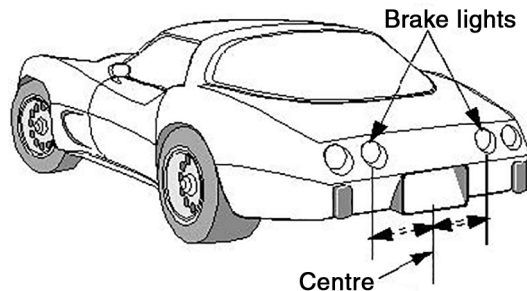

- (3) The centre of a brake light must be—
 - (a) at least 350mm above ground level; and
 - (b) not more than—
 - (i) 1.5m above ground level; or
 - (ii) if it is not practicable to fit the light in accordance with subparagraph (i)—2.1m above ground level.
- (4) A vehicle may be fitted with 1 or more additional brake lights.
- (5) The centre of an additional brake light must be at least 350mm above ground level.
- (6) If only 1 brake light is fitted to a vehicle, it must be fitted in the centre, or to the right of the centre, of the vehicle's rear.
- (7) Subsection (6) applies to a motorbike with a sidecar as if the motorbike did not have a sidecar.
- (8) For this section, a light fitted to a vehicle built before 1 January 1973 that functions as a brake light and a direction indicator light is taken to be a brake light.

95 Performance and operation of brake lights

- (1) When on, a brake light fitted to a vehicle must show a red light visible at least 30m from the rear of the vehicle.
- (2) A brake light fitted to a street rod vehicle may incorporate a blue lens not more than 20mm in diameter.
- (3) A brake light fitted to a motor vehicle must come on, if it is not already on, when—
 - (a) for a vehicle with 4 or more wheels or a vehicle built after 1974—a service brake is applied; or
 - (b) for another vehicle—the rear wheel brake is applied.
- (4) Subsection (3) does not apply if the controls of the motor vehicle that start the engine are in a position making it impossible for the engine to operate.
- (5) A brake light fitted to a trailer must come on when—
 - (a) the brake light of the trailer’s towing vehicle comes on; or
 - (b) a brake control on the trailer’s towing vehicle, which independently activates the service brake on the trailer, is operated.
- (6) A brake light may be operated by an engine brake, retarder or similar device if the device does not interfere with the proper operation of the brake light.

Division 11 Reversing lights

96 Reversing lights

- (1) One or more reversing lights may be fitted to the rear of a vehicle and on each side of the vehicle towards its rear.
- (2) A reversing light fitted to a vehicle must have its centre not more than 1.2m above ground level.
- (3) When on, a reversing light fitted to a vehicle must show a white or yellow light to the rear, or to the side and rear, of the vehicle.

Note—

Third edition ADRs only allow white reversing lights.

- (4) A reversing light fitted to a motor vehicle must be wired so it operates only when the vehicle is reversing or in reverse gear.
- (5) A reversing light fitted to a trailer must be wired so it operates only when a motor vehicle towing the trailer is reversing or in reverse gear.
- (6) A yellow reversing light fitted to a vehicle may also operate as a direction indicator light for the vehicle.

Division 12 Direction indicator lights

97 Direction indicator lights on motor vehicles

- (1) A motor vehicle with 4 or more wheels built after August 1966 must have—
 - (a) a pair of direction indicator lights fitted on, or towards, its front facing forwards; and
 - (b) a pair of direction indicator lights fitted on, or towards, its rear facing backwards.
- (2) A motor vehicle with fewer than 4 wheels built after June 1975 must have—
 - (a) a pair of direction indicator lights fitted on, or towards, its front facing forwards; and
 - (b) a pair of direction indicator lights fitted on, or towards, its rear facing backwards.
- (3) A motor vehicle that is not required to have direction indicator lights may have—
 - (a) 1 or more pairs of direction indicator lights visible from both the front and rear of the vehicle; or
 - (b) both—
 - (i) a pair of direction indicator lights fitted on, or towards, its front facing forwards; and

- (ii) a pair of direction indicator lights fitted on, or towards, its rear facing backwards.

98 Direction indicator lights on trailers

- (1) A trailer built after June 1973 must have a pair of direction indicator lights fitted on, or towards, its rear facing backwards.
- (2) A trailer that is not required to have direction indicator lights may have 1 or more pairs of direction indicator lights fitted on, or towards, its rear facing backwards.

99 Location of direction indicator lights

- (1) A pair of direction indicator lights fitted to a vehicle must have the centre of each light fitted at least—
 - (a) for a motorbike or the single wheel end of a motortrike—300mm from the centre of the other light; and
 - (b) for the 2 wheel end of a motortrike—600mm from the centre of the other light, unless the centre of each light is not more than 400mm from the nearer side of the motortrike; and
 - (c) for another vehicle with a width of not more than 1,300mm—400mm from the centre of the other light; and
 - (d) for another vehicle with a width of more than 1,300mm—600mm from the centre of the other light.
- (2) The centre of each direction indicator light fitted to a vehicle must be at least 350mm above ground level.
- (3) The centre of each light in a pair of direction indicator lights fitted to a vehicle must not be more than—
 - (a) 1.5m above ground level; or
 - (b) if it is not practicable for the light to be fitted lower—2.1m above ground level.

100 Operation and visibility of direction indicator lights

- (1) A direction indicator light fitted to a motor vehicle must—
 - (a) when operating, display regular flashes of light at a rate of—
 - (i) for a motor vehicle with 4 or more wheels—at least 60, but not more than 120, flashes a minute; and
 - (ii) for another motor vehicle—at least 45, but not more than 120, flashes a minute; and
 - (b) be able to be operated by the driver from the normal driving position of the vehicle; and
 - (c) be wired to a visible or audible device in the vehicle that tells the driver, in the normal driving position of the vehicle, the direction indicator light is operating; and
 - (d) flash at the same time and rate as any other direction indicator lights fitted on the same side of the vehicle.
- (2) A direction indicator light fitted to a side of a trailer must, when operating, flash at the same time and rate as the direction indicator light or lights fitted to the same side of the trailer's towing vehicle.
- (3) The flashes of light displayed by a direction indicator light must be—
 - (a) for a light facing forwards—white or yellow; and
 - (b) for a light facing backwards—
 - (i) yellow; or
 - (ii) for a vehicle built before July 1973—yellow or red; and
 - (c) for a light facing outwards from a side of the vehicle—
 - (i) white or yellow towards the front and side of the vehicle; and
 - (ii) for a vehicle built before July 1973—yellow or red towards the rear and side of the vehicle; and
 - (iii) for a vehicle built after June 1973—yellow towards the rear and side of the vehicle.

Note—

The ADRs only allow yellow direction indicator lights.

- (4) A motor vehicle may be equipped to allow the direction indicator lights fitted on both sides of the vehicle to operate simultaneously if—
 - (a) the lights display only yellow light; and
 - (b) a visible or audible signal tells the driver when the lights are operating simultaneously.
- (5) When on, a direction indicator light fitted to a vehicle must be visible at least 30m from—
 - (a) for a light facing forwards—the front of the vehicle; or
 - (b) for a light facing backwards—the rear of the vehicle; or
 - (c) for a light facing outwards from a side of the vehicle—the side of the vehicle.
- (6) For a prime mover or another motor vehicle more than 7.5m long, each direction indicator light in at least 1 pair of lights fitted on, or towards, the front of the vehicle must, when on, be visible at a point—
 - (a) at least 1.5m at a right angle from the side of the prime mover or other motor vehicle to which the light is fitted; and
 - (b) in line with the rear of the prime mover or other motor vehicle.

Division 13 Fog lights

101 Front fog lights

- (1) A pair of front fog lights may be fitted to a motor vehicle with 4 or more wheels.
- (2) A pair of front fog lights, or a single front fog light, may be fitted to a motorbike or motortrike.
- (3) A pair of front fog lights fitted to a motor vehicle with 4 or more wheels must have the centre of each light not more than

400mm from the nearer side of the vehicle unless the centres of the lights are at least 600mm apart.

- (4) If the top of the front fog light fitted to a vehicle is higher than the top of any low-beam headlight fitted to the vehicle, the centre of the fog light must not be higher than the centre of the low-beam headlight.
- (5) A front fog light fitted to a vehicle must—
 - (a) when on—
 - (i) project white or yellow light in front of the vehicle; and
 - (ii) be a low-beam light; and
 - (b) be able to be operated independently of any headlight fitted to the vehicle; and
 - (c) be fitted so the light from it does not reflect off the vehicle into the eyes of the driver in the normal driving position of the vehicle.

102 Rear fog lights

- (1) A vehicle may have—
 - (a) a pair of rear fog lights fitted to its rear; or
 - (b) 1 rear fog light fitted to, or to the right of, the centre of the rear of the vehicle.
- (2) Subsection (1)(b) applies to a motorbike with a sidecar as if the motorbike did not have a sidecar.
- (3) A rear fog light fitted to a vehicle must—
 - (a) have its centre—
 - (i) not more than 1.5m above ground level; and
 - (ii) at least 100mm from the centre of a brake light for the vehicle; and
 - (b) when on, project red light behind the vehicle; and
 - (c) not use more than 27W; and

- (d) be wired to a visible device in the vehicle that tells the vehicle's driver that the light is operating.
- (4) In this section—
- rear fog light* means a light fitted to a vehicle to make the vehicle more easily visible, from the rear, in dense fog.

Division 14 Interior lights

103 Interior lights

A vehicle may be fitted with interior lights that illuminate any interior part of the vehicle.

Division 15 Reflectors generally

104 General requirements for reflectors

- (1) A reflector fitted to a vehicle must show a red, white or yellow reflection of light when light is projected directly onto the reflector at night by a low-beam headlight of another vehicle if the headlight of the other vehicle—
 - (a) is 45m from the reflector; and
 - (b) complies with this schedule.
- (2) The reflection must be clearly visible by the driver in the normal driving position of the other vehicle.

Division 16 Rear reflectors

105 Rear reflectors

- (1) A motor vehicle with 4 or more wheels, or a trailer, must be fitted towards each side of its rear with a rear-facing reflector that shows a red reflection of light.

- (2) A motorbike, motorbike with a sidecar or motortrike must be fitted on its rear with 1 rear-facing reflector that shows a red reflection of light.
- (3) The centre of each reflector fitted to the vehicle must be—
 - (a) at the same height above ground level; and
 - (b) not more than 1.5m above ground level.
- (4) However, subsection (3) does not apply to a reflector fitted to a sidecar of a motorbike.
- (5) A reflector fitted to a motor vehicle with 4 or more wheels, or a trailer, must not be more than 400mm from the nearer side of the vehicle.
- (6) A vehicle fitted with reflectors in accordance with subsection (1) or (2) may be fitted with additional rear-facing reflectors that show a red reflection of light—
 - (a) at any height above ground level; or
 - (b) at any distance from the nearer side of the vehicle.

Division 17 Side reflectors

106 Compulsory side reflectors on pole-type trailers

- (1) Side-facing reflectors that show a red or yellow reflection of light must be fitted to the pole of a pole-type trailer as follows—
 - (a) 1 reflector must be fitted to the middle third of the left and right faces of the pole;
 - (b) the front reflector must be not more than 3m from the front of the trailer;
 - (c) the other reflectors must not be more than 3m apart.
- (2) Additional side-facing reflectors may be fitted to a pole-type trailer in accordance with section 107.

107 Optional side reflectors

- (1) A vehicle may be fitted with side-facing reflectors.
- (2) A side-facing reflector must show a reflection of light that is—
 - (a) for a side-facing reflector fitted towards the front of the vehicle—white or yellow; and
 - (b) for a side-facing reflector fitted towards the rear of the vehicle—red or yellow; and
 - (c) for a side-facing reflector fitted on the central part of the vehicle—yellow.

Division 18 Front reflectors

108 Compulsory front reflectors on particular trailers

- (1) A front-facing reflector that shows a white or yellow reflection of light must be fitted to each side of the front of—
 - (a) a semitrailer, other than a pole-type trailer; or
 - (b) the front cross-bar or bolster of a pole-type trailer; or
 - (c) a trailer that is at least 2.2m wide.
- (2) Each reflector must have its centre—
 - (a) at the same height above ground level; and
 - (b) not more than 1.5m above ground level; and
 - (c) not more than 400mm from the nearer side of the vehicle.
- (3) Additional front-facing reflectors may be fitted to a trailer mentioned in subsection (1) in accordance with section 109.

109 Optional front reflectors

- (1) A motor vehicle with 4 or more wheels, or a trailer, may have fitted towards each side of its front 1 or more front-facing reflectors that show a white or yellow reflection of light.

- (2) A motor vehicle with fewer than 4 wheels may have 1 or more front-facing reflectors that show a white or yellow reflection of light.
- (3) The centre of at least 1 of the reflectors fitted to each side of the front of the vehicle must be—
 - (a) at the same height above ground level as the centre of the other reflector; and
 - (b) the same distance from the longitudinal axis of the vehicle as the centre of the other reflector; and
 - (c) at least—
 - (i) for a vehicle with a width of less than 1,300mm—400mm from the centre of the other reflector; and
 - (ii) for another vehicle—600mm from the centre of the other reflector.

Division 19 Warning lights and signs on buses carrying children

110 Application of division

This division applies to a vehicle that is a bus used mainly for carrying children other than a bus fitted with warning lights before July 1999.

Note—

See also the Queensland Road Rules, sections 222 and 222A.

111 Fitting of warning lights and signs

- (1) Two warning lights and a warning sign must be fitted to the front and rear of the bus.
- (2) The warning lights must be fitted—
 - (a) on each side of, and the same distance from, the centre of the warning sign; and

- (b) with the edge of the warning sign not over 100mm from the nearest point on the lens of the warning lights; and
 - (c) with the distance between the warning lights at least 300mm at the nearest point; and
 - (d) so no part of the bus obstructs the light displayed—
 - (i) 30° to the left and right of the centre of each light; and
 - (ii) 10° above and below the centre of each light.
- (3) The warning lights may be on the warning sign if the words or image on the sign are not obscured.
- (4) The warning lights at the same end of the bus must be fitted—
- (a) at the same height; and
 - (b) as high as practicable; and
 - (c) with the lowest point on the lens of each light not lower than midway between the highest and lowest points on the bus body.
- (5) If the centres of the warning lights are under 1.8 metres above ground level, no part of the warning lights or warning sign may be on the left of the bus.
- (6) Any requirement of a third edition ADR about warning lights and warning signs does not apply to a bus to which this division applies.

112 Operation and performance of warning lights

- (1) A warning light attached to the bus, when operating, must emit a flashing yellow light.
- (2) The warning lights at the same end of the bus must flash alternately between 90 and 180 times each minute.
- (3) Unless the driver has turned the warning lights off, they must operate automatically when a passenger door on the bus opens and for at least 10, and not more than 20 seconds, after all the doors on the bus have closed.

Schedule 1

- (4) The bus must have an audible or visible signal that tells the driver of the bus in the normal driving position when the warning lights are flashing.
- (5) The bus must be fitted with a switch that allows the driver of the bus to turn the warning lights off from the normal driving position.
- (6) A warning light must have—
 - (a) an effective lit lens area of at least 60cm²; and
 - (b) a luminous intensity (in candela) of at least the values mentioned in the following table when measured at the angles mentioned in the table.

Vertical angle from centre of light	Horizontal angle from centre of light								
	-30°	-20°	-10°	-5°	0°	5°	10°	20°	30°
10°				50	80	50			
5°		180	320	350	450	350	320	180	
0°	75	450	1000	1250	150	1250	1000	450	75
				0					
-5°	40	270	450	570	600	570	450	270	40
-10°				75	75	75			

- (7) For the purposes of subsection (6)(b), the luminous intensity of a light is to be measured in accordance with the test method mentioned in third edition ADR 6.

113 Specifications for warning signs

- (1) A warning sign at the front of the bus must—
 - (a) display the words ‘SCHOOL BUS’ in capital letters at least 100mm high; or
 - (b) the required image.
- (2) A warning sign at the rear of the bus must show the required image.

- (3) The warning sign showing the required image must—
 - (a) be a rectangular shape at least—
 - (i) if warning lights are on the warning sign—550mm long and 400mm high; or
 - (ii) otherwise—400mm long and 250mm high; and
 - (b) have a black border; and
 - (c) have black graphics; and
 - (d) have a yellow surface complying with class 1, 2, 400 or 100 of the version of AS/NZS 1906 ‘Retroreflective materials and devices for road traffic control purposes’ applying to the warning sign at the sign’s date of manufacture.
- (4) In this section—

required image means an image of 2 children in the same proportions as the children in AS 1743 ‘Road Signs—Specifications’, image W6-3, with the image of the taller child at least 230mm high.

Division 20 Other lights, reflectors, rear marking plates or signals

114 Other lights and reflectors

- (1) Despite a requirement of a third edition ADR, an exempt vehicle may be fitted with any light or reflector.
- (2) Despite a requirement of a third edition ADR, a special use vehicle may be fitted with 1 or more flashing yellow lights.
- (3) A vehicle may be fitted with a light or reflector not permitted under this schedule only if the light or reflector is required or permitted to be fitted to a vehicle under an Act.
- (4) A vehicle, other than an exempt vehicle or special use vehicle, must not be fitted with a light that flashes other than as required or permitted under an Act.

- (5) A vehicle, other than an exempt vehicle, must not be fitted with a light or reflector that—
- (a) shows or reflects a red light to the front; or
 - (b) shows or reflects a white light to the rear; or
 - (c) is shaped or located in a way that reduces the effectiveness of another light or reflector required to be fitted to the vehicle under this schedule.

- (6) In this section—

exempt vehicle means—

- (a) an Airservices Australia vehicle; or
- (b) an Australian Border Force vehicle; or
- (c) an emergency vehicle; or
- (d) a police vehicle; or
- (e) a transport enforcement vehicle; or
- (f) a vehicle used by the National Heavy Vehicle Regulator for enforcement of the Heavy Vehicle National Law.

special use vehicle means any of the following vehicles—

- (a) a vehicle built or fitted for use in hazardous situations on a road;
- (b) a vehicle used on a road under a safe movement approval;
- (c) a vehicle built or fitted to accompany—
 - (i) a vehicle mentioned in paragraph (b); or
 - (ii) a vehicle used on a road under an exemption from a requirement about the dimensions of a heavy vehicle under an Act;
- (d) a vehicle that is a bus fitted, before July 1999, with a sign telling road users that the bus carries children.

115 Rear marking plates and conspicuity markings

- (1) Rear marking plates or conspicuity markings may be fitted to—
- (a) a motor vehicle; or
 - (b) a trailer.

Note—

See also the Vehicle Standards Bulletin titled ‘VSB 12—National Code of Practice—Rear Marking Plates’ for requirements about ‘Do not overtake turning vehicle’ signs that may apply to a vehicle fitted with conspicuity markings.

Example of rear marking plates fitted to a motor vehicle—

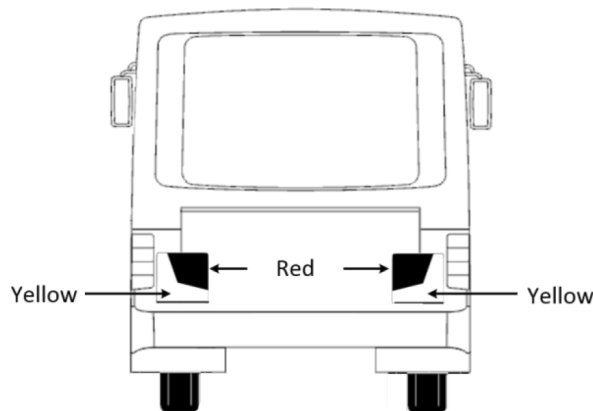

Example of an alternative pattern for rear marking plates—

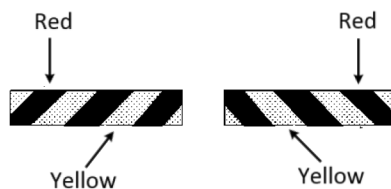

- (2) In this section—

conspicuity marking means a conspicuity marking within the meaning of ADR 13/00.

rear marking plate means a rear marking plate that complies with the Vehicle Standards Bulletin titled ‘VSB 12—National Code of Practice—Rear Marking Plates’.

Note—

The Vehicle Standards Bulletin titled ‘VSB 12—National Code of Practice—Rear Marking Plates’ is available from the National Heavy Vehicle Regulator’s website.

116 Signalling devices

- (1) This section applies to a motor vehicle if—
 - (a) the vehicle is not fitted with a brake light mentioned in division 10 or direction indicator light mentioned in division 12; and
 - (b) the construction of the vehicle would otherwise prevent the driver from the normal driving position of the vehicle from hand signalling an intention—
 - (i) to turn or move the vehicle to the right; or
 - (ii) to stop or suddenly reduce the vehicle’s speed.
- (2) The vehicle must be fitted with—
 - (a) a mechanical signalling device complying with section 117; or
 - (b) a pair of turn signals complying with section 118.

117 Mechanical signalling devices

- (1) A mechanical signalling device for a motor vehicle must—
 - (a) be fitted to the right side of the vehicle; and
 - (b) be able to be operated by the driver from the normal driving position of the vehicle; and
 - (c) consist of a white or yellow representation of an open human hand at least 15cm long; and
 - (d) be constructed so the driver of the vehicle can keep the device—

- (i) in a neutral position so it is unlikely that the driver of another vehicle or anyone else would regard it as a signal; and
 - (ii) in a horizontal position with the palm of the hand facing forwards and the fingers pointing out at a right angle to the vehicle to signal an intention to turn or move the vehicle to the right; and
 - (iii) with the palm of the hand facing forwards and the fingers pointing upwards to signal an intention to stop or suddenly reduce the vehicle's speed.
- (2) When the mechanical signalling device is in a position mentioned in subsection (1)(d)(ii) or (iii), the complete hand must be clearly visible from both the front and the rear of the vehicle, at a distance of at least 30m.

118 Turn signals

A turn signal fitted to a motor vehicle must—

- (a) consist of a steady or flashing illuminated yellow sign of at least 150mm long and 25mm wide that—
 - (i) when in operation—is kept horizontal; and
 - (ii) when not in operation—is kept in a position so it is unlikely that the driver of another vehicle or anyone else would regard it as a signal; and
- (b) be fitted to the side of the vehicle at least 500mm, but not more than 2.1m, above ground level, in a position so the driver, in the normal driving position of the vehicle, can see whether the signal is in operation; and
- (c) be able to be operated by the driver from the normal driving position of the vehicle; and
- (d) when in operation, be visible from both the front and rear of the vehicle at a distance of at least 30m.

Part 8 Braking systems

Division 1 Brake requirements for all vehicles

119 Components of a braking system

A brake tube or hose fitted to a vehicle must—

- (a) be manufactured from a material appropriate for the intended use of the tube or hose in the vehicle; and
- (b) be long enough to allow for the full range of steering and suspension movements of the vehicle; and
- (c) be fitted to prevent the tube or hose from being damaged during the operation of the vehicle by—
 - (i) a source of heat; or
 - (ii) any movement of the parts the tube or hose is attached to or near.

120 Provision for wear

The braking system of a vehicle must allow for adjustment to take account of normal wear in the braking system.

121 Supply of air or vacuum to brakes

- (1) If air brakes are fitted to a vehicle—
 - (a) the vehicle's air brake compressor must be able to build up air pressure to at least 80% of the vehicle's governor cut-out pressure in 5 minutes or less after the compressed air reserve is fully used up; and
 - (b) there must be an automatic or manual condensate drain valve at the lowest point of each air brake reservoir in the vehicle's braking system; and
 - (c) a spring brake fitted to the vehicle must not operate before the warning mentioned in section 125(4)(a) or 128(3)(a) is given.

-
- (2) If vacuum brakes are fitted to a vehicle, the vacuum supply must be able to build up vacuum—
- (a) to the level when the warning signal mentioned in section 125(4)(a) or 128(3)(a) no longer operates within 30 seconds after the vacuum reserve is fully used up; and
 - (b) to the normal working level within 60 seconds after the vacuum reserve is fully used up.
- (3) In this section—

air brake compressor, of a vehicle, means a compressor for supplying air to the vehicle's air brakes.

compressed air reserve, for a vehicle, means compressed air stored on the vehicle for supplying the vehicle's braking system.

condensate drain valve means a device used to remove water from the compressed air reserve for a vehicle fitted with air brakes.

governor cut-out pressure, of a vehicle, means the air pressure at which the vehicle's air brake compressor stops supplying air to the vehicle's air brake reservoir.

spring brake means a brake using 1 or more springs to store the energy needed to operate the brake.

vacuum reserve, in relation to a vehicle, means air at low pressure stored on the vehicle for supplying the vehicle's braking system.

122 Performance of braking systems

- (1) One sustained application of the brake of a motor vehicle built after 1930, or a combination that includes a motor vehicle built after 1930, must be able to produce the performance mentioned in subsections (2) to (7)—
- (a) when the vehicle or combination is on a dry, smooth, level road surface, free from loose material; and
 - (b) whether or not the vehicle or combination is loaded; and

- (c) without part of the vehicle or combination moving outside a straight path—
 - (i) centred on the longitudinal axis of the vehicle or combination before the brake is applied; and
 - (ii) 3.7m wide.
- (2) The braking system of a motor vehicle or combination with a loaded mass of less than 2.5t must bring the vehicle or combination from a speed of 35km/h to a stop within—
 - (a) when the service brake is applied—12.5m; and
 - (b) when the emergency brake is applied—30m.
- (3) The braking system of a motor vehicle or combination with a loaded mass of 2.5t or more must bring the vehicle or combination from a speed of 35km/h to a stop within—
 - (a) when the service brake is applied—16.5m; and
 - (b) when the emergency brake is applied—40.5m.
- (4) The braking system of a motor vehicle or combination with a loaded mass of less than 2.5t must decelerate the vehicle or combination, from any speed at which the vehicle or combination can travel, by an average of at least—
 - (a) when the service brake is applied— 3.8m/s^2 ; and
 - (b) when the emergency brake is applied— 1.6m/s^2 .
- (5) The braking system of a motor vehicle or combination with a loaded mass of 2.5t or more must decelerate the vehicle or combination, from any speed at which the vehicle or combination can travel, by an average of at least—
 - (a) when the service brake is applied— 2.8m/s^2 ; and
 - (b) when the emergency brake is applied— 1.1m/s^2 .
- (6) The braking system of a motor vehicle or combination with a loaded mass of less than 2.5t must achieve a peak deceleration of the vehicle or combination, from any speed at which the vehicle or combination can travel, of at least—
 - (a) when the service brake is applied— 5.8m/s^2 ; and
 - (b) when the emergency brake is applied— 1.9m/s^2 .

-
- (7) The braking system of a motor vehicle or combination with a loaded mass of 2.5t or more must achieve a peak deceleration of the vehicle or combination, from any speed at which the vehicle or combination can travel, of at least—
 - (a) when the service brake is applied— 4.4m/s^2 ; and
 - (b) when the emergency brake is applied— 1.5m/s^2 .
 - (8) The parking brake of a vehicle or combination must be able to hold the vehicle or combination stationary on a 12% gradient—
 - (a) when the vehicle or combination is on a dry, smooth road surface free from loose material; and
 - (b) whether or not the vehicle or combination is loaded.

Division 2 Motor vehicle braking systems

123 What braking system motor vehicle must have

- (1) A motor vehicle with 4 or more wheels built, or used, mainly for transporting goods or people by road must be fitted with—
 - (a) a braking system that—
 - (i) consists of brakes fitted to all wheels of the vehicle; and
 - (ii) has at least 2 separate methods of activation, arranged so effective braking remains on at least 2 wheels if 1 method fails; or
 - (b) 2 independent brakes, each of which, when in operation, acts directly on at least half the number of wheels of the vehicle.
- (2) The braking system of a motor vehicle mentioned in subsection (1) and built after 1945 must have a service brake operating on all wheels that, when applied—
 - (a) acts directly on the vehicle's wheels and not through the vehicle's transmission; or

- (b) acts on a shaft between a differential and a wheel of the vehicle.
- (3) The braking system of a motor vehicle with 4 or more wheels must have a parking brake that—
 - (a) is held in the applied position by direct mechanical action without the intervention of an electrical, hydraulic or pneumatic device; and
 - (b) is fitted with a locking device that can hold the brake in the applied position; and
 - (c) has its own separate control.
- (4) The parking brake may also be the emergency brake.
- (5) If 2 or more independent brakes are fitted to a motor vehicle with 4 or more wheels, the brakes must be arranged so brakes are applied to all of the wheels on at least 1 axle of the vehicle when any brake is operated.
- (6) A motorbike or motortrike must be fitted with—
 - (a) 2 independent brakes; or
 - (b) a single brake that acts directly on all wheels of the vehicle and is arranged so effective braking remains on at least 1 wheel if a part of the braking system fails.
- (7) Subsection (6) applies to a motorbike with a sidecar as if the motorbike did not have a sidecar.
- (8) A motortrike must have a parking brake that is held in the applied position by mechanical means.
- (9) In this section—

independent brake, for a vehicle, means a brake operated entirely separately from another brake on the vehicle, other than a drum, disc or other part of the brake on which a shoe, band or friction pad makes contact and is common to the brake and 1 or more other brakes.

124 Operation of brakes on motor vehicles

The braking system fitted to a motor vehicle must be arranged to allow the vehicle's driver, from the normal driving position of the vehicle, to apply the brakes.

125 Air or vacuum brakes on motor vehicles

- (1) If a motor vehicle has air brakes, the vehicle's braking system must include at least 1 air storage tank.
- (2) If a motor vehicle has vacuum brakes, the vehicle's braking system must include at least 1 vacuum storage tank.
- (3) An air or vacuum storage tank must be built so the vehicle's service brake can be applied to meet the performance standards of section 122 at least twice if the vehicle's engine stops or the source of air or vacuum fails.
- (4) An air or vacuum storage system must—
 - (a) be built to give a visible or audible warning to the driver, in the normal driving position of the vehicle, of a lack of air or vacuum that would prevent the vehicle's service brake from being applied to meet the performance standards under section 122 at least twice; and
 - (b) be safeguarded by a check valve or other device against loss of air or vacuum if the supply fails or leaks.
- (5) However, subsection (4)(a) does not apply to a vehicle that is fitted with an air or vacuum assisted braking system.
- (6) If air or vacuum brakes are fitted to a motor vehicle equipped to tow a trailer, the vehicle's brakes must be able to stop the vehicle, at the performance standards for emergency brakes under section 122, if the trailer breaks away.

Note—

Subsections (4)(a), (5) and (6) are additional Queensland provisions.

Division 3 Trailer braking systems

126 What brakes a trailer must have

- (1) A trailer with a GTM of more than 750kg must have brakes that operate on at least 1 wheel at each end of 1 or more axles of the trailer.
- (2) A semitrailer or converter dolly with a GTM of more than 2t must have brakes that operate on all its wheels.

127 Operation of brakes on trailers

- (1) The braking system of a trailer with a GTM of more than 2t must allow the driver of the trailer's towing vehicle, from a normal driving position of the towing vehicle, to operate the trailer's brakes.
- (2) The brakes on a trailer with a GTM of more than 2t must—
 - (a) operate automatically and quickly if the trailer breaks away from the towing vehicle; and
 - (b) remain in operation for at least 15 minutes after a break-away; and
 - (c) while in operation after a break-away, be able to hold the trailer on a 12% grade.

128 Air or vacuum brakes on trailers

- (1) If a trailer is fitted with air brakes, the braking system for the trailer must include at least 1 air storage tank.
- (2) If a trailer is fitted with vacuum brakes, the braking system for the trailer must include at least 1 vacuum storage tank.
- (3) An air or vacuum storage system for a trailer must—
 - (a) be built to give a visible or audible warning to the driver of the trailer's towing vehicle, in the normal driving position of the towing vehicle, of a lack of air or vacuum that would prevent the trailer's brakes from meeting the performance standards of section 122; and

- (b) be safeguarded by a check valve or other device against loss of air or vacuum if the supply of air or vacuum fails or leaks.
- (4) This section does not apply to a trailer with a GTM of 2t or less.

Part 9 Control of emissions

Division 1 Crank case gases and exhaust emissions

129 Crank case gases

- (1) This section applies to a motor vehicle with 4 or more wheels built after 1971 that is powered by a petrol engine.
- (2) The vehicle must be built to prevent, or fitted with equipment that prevents, gases emitted from the vehicle's engine crank case escaping to the atmosphere.

130 Visible emissions—vehicles with internal combustion engines

- (1) This section applies to a motor vehicle built after 1930 that is propelled by an internal combustion engine.
- (2) The vehicle must not emit visible emissions for a continuous period of 10 seconds or more.
- (3) However, this section does not apply to emissions that are visible only because of heat or the condensation of water vapour.

131 Sections 131–133 not used

See note to section 1.

Division 2 Exhaust systems

134 Exhaust systems

- (1) The outlet of the exhaust system fitted to a motor vehicle, other than a bus, must extend—
 - (a) behind the back seat; and
 - (b) at least 40mm past the outermost joint of the floorpan that is not continuously welded or permanently sealed; and
 - (c) to the edge of the vehicle, if—
 - (i) the body of the vehicle is permanently enclosed; and
 - (ii) the vehicle is not fitted with a vertical exhaust system; and
 - (d) no further than the edge of the vehicle at its widest point.
- (2) The outlet must discharge the main exhaust flow to the air—
 - (a) if the vehicle is fitted, or required to be fitted, with an exhaust system with a vertical outlet pipe—
 - (i) at an angle above the horizontal; and
 - (ii) at least 150mm above the cab of the vehicle; and
 - (iii) towards the rear, or to the right, of the vehicle; or
 - (b) otherwise—
 - (i) horizontally or at an angle of not over 45° downwards; and
 - (ii) under 750mm above ground level; and
 - (iii) towards the rear, or to the right, of the vehicle.
- (3) Subsections (1) and (2)(b) do not apply to a goods vehicle with—
 - (a) 3 wheels and a GVM of more than 1t but not more than 4.5t; or

- (b) more than 3 wheels and a GVM of not more than 4.5t.

Division 3 Noise emissions

Subdivision 1 General

135 Measurement of stationary noise levels

For this division, the stationary noise level of a motor vehicle must be measured in accordance with the procedure set out for the type of vehicle in the document titled ‘National Stationary Exhaust Noise Test Procedures for In-Service Motor Vehicles—September 2006’ published by the National Transport Commission.

Note—

The National Stationary Exhaust Noise Test Procedures for In-Service Motor Vehicles—September 2006 is available on the National Transport Commission’s website.

136 Meaning of *certified to ADR 83/00*

For this division, a vehicle is *certified to ADR 83/00* if—

- (a) approval has been given to place identification plates showing compliance with ADR 83/00 on vehicles of that type under—
- (i) the repealed *Motor Vehicle Standards Act 1989* (Cwlth), section 10A; or
 - (ii) the *Road Vehicle Standards (Consequential and Transitional Provisions) Act 2018* (Cwlth), schedule 3, item 4(2) or 6(2); or
- (b) the vehicle—
- (i) has satisfied the requirements of an entry pathway under the *Road Vehicle Standards Act 2018* (Cwlth), section 15(2), including compliance with ADR 83/00; and

(ii) is entered on the RAV.

137 Silencing device for exhaust systems

- (1) A motor vehicle propelled by an internal combustion engine must be fitted with a silencing device through which exhaust from the engine passes.
- (2) For subsection (1), a silencing device designed to be manipulated by the vehicle's driver, for example, by using in-vehicle controls, must be designed so the device can be tested with the device being fully opened.

Subdivision 2 Noise levels applying to vehicles not certified to ADR 83/00

138 Application of subdivision

This subdivision applies to a motor vehicle other than a vehicle certified to ADR 83/00.

139 Stationary noise levels—car-type vehicles, motorbikes or motortrikes

- (1) The stationary noise level of a car-type vehicle, motorbike or motortrike must not be more than—
 - (a) for a car-type vehicle built after 1982—90dB(A); or
 - (b) for another car-type vehicle—96dB(A); or
 - (c) for a motorbike or motortrike built after February 1985—94dB(A); or
 - (d) for another motorbike or motortrike—100dB(A).
- (2) In this section—

car-type vehicle means—

 - (a) a car; or
 - (b) a utility truck, panel van or another motor vehicle derived from a car design; or

- (c) another motor vehicle—
- (i) built mainly to seat 9 or fewer adults; and
 - (ii) that has 4 or more wheels.

140 Stationary noise levels—other vehicles with spark ignition engines

- (1) This section applies to a motor vehicle with a spark ignition engine, other than a motor vehicle to which section 139 applies.
- (2) The stationary noise level of the motor vehicle must not exceed the noise level stated for the motor vehicle in the following table—

GVM (t)	Exhaust height (mm)	When vehicle was built	Noise level (dB(A))
≤3.5	<1,500	before July 1983	92
		after June 1983	89
>3.5	<1,500	before July 1983	98
		after June 1983	95
≥3.5	≥1,500	before July 1983	88
		after June 1983	85
>3.5	≥1,500	before July 1983	94
		after June 1983	91

141 Stationary noise levels—other vehicles with diesel engines

- (1) This section applies to a motor vehicle with a diesel engine, other than a motor vehicle to which section 139 applies.
- (2) The stationary noise level of the motor vehicle must not exceed the noise level stated for the vehicle in the following table—

GVM (t)	Exhaust height (mm)	When vehicle was built	Noise level (dB(A))
≤3.5	<1,500	before July 1980	105
		after June 1980 but before July 1983	102
		after June 1983	99
>3.5	<1,500	before July 1980	107
		after June 1980 but before July 1983	104
		after June 1983	101
≤3.5	≥1,500	before July 1980	101
		after June 1980 but before July 1983	98
		after June 1983	95
>3.5	≥1,500	before July 1980	103
		after June 1980 but before July 1983	100
		after June 1983	97

Subdivision 3 Noise levels applying to vehicles certified to ADR 83/00

142 Stationary noise levels

- (1) The stationary noise level of a motor vehicle that is certified to ADR 83/00 must not exceed, by more than 5dB(A), the noise level stated in the ADR 83/00 approval notice given when the motor vehicle is certified.

- (2) In this section—

ADR 83/00 approval notice, for a motor vehicle certified to ADR 83/00, means the notice of approval showing the

vehicle's compliance with ADR 83/00 given for the motor vehicle under the *Vehicle Standard (Australian Design Rule 83/00—External Noise) 2005* (Cwlth).

Note—

Subsection (2) is an additional Queensland provision.

Part 10 Alternative fuel systems

143 LPG-powered vehicles

- (1) An LPG system installed in a motor vehicle, and the vehicle, must comply with all relevant requirements set out in AS 1425 as in force when the system was installed in the vehicle.
- (2) A motor vehicle that has an LPG system installed must have fixed conspicuously to its front and rear number plates the labels required by AS 1425 as in force when the system was installed in the vehicle.
- (3) If a motor vehicle had an LPG system installed before AS 1425 was first published, the vehicle must have fixed conspicuously to its front and rear number plates a label—
 - (a) that is made of durable material; and
 - (b) that is at least 25mm wide and 25mm high; and
 - (c) that is of a reflective red that conforms with either AS 1743—1992, Appendix C, class 2 (Australian Standard for road signs—specifications—retroreflective colours) or AS 1906.1, class 2 (Australian Standard for retroreflective materials and devices for road traffic control purposes—retroreflective sheeting); and
 - (d) that states ‘LPGAS’ or ‘LPG’, or similar words or acronyms that have the same meaning, in upper case letters at least 6mm high.
- (4) In this section—

AS 1425 means AS 1425 (Australian Standard for LP gas fuel systems for vehicle engines).

144 Vehicles powered by natural gas

A natural gas system installed in a motor vehicle, and the vehicle, must comply with all relevant requirements set out in AS 2739 (Australian Standard for natural gas (NG) fuel systems for vehicle engines) as in force when the system was installed in the vehicle.

Examples of natural gas systems—

compressed natural gas (CNG) fuel system, liquid natural gas (LNG) fuel system

144A Hydrogen-powered vehicles

- (1) A hydrogen-powered vehicle built, or a vehicle modified to be a hydrogen-powered vehicle, after 1 January 2019 must have fixed conspicuously to its front and rear number plates—
 - (a) for a vehicle fitted with 1 hydrogen fuel container—a label complying with subsection (2); or
 - (b) for a vehicle fitted with 2 or more hydrogen fuel containers—2 labels that comply with subsection (2).
- (2) For subsection (1), a label complies with this subsection if—
 - (a) it is affixed to a plate made of metal at least 1mm thick; and
 - (b) the label, and the plate to which it is affixed, is a regular pentagonal shape with—
 - (i) each side 20mm long; and
 - (ii) each interior angle 108°; and
 - (c) it has a yellow surface complying with class 2 of AS 1906.1 (Australian Standard for retroreflective materials and devices for road traffic control purposes—retroreflective sheeting); and
 - (d) it is marked ‘H’ in a black upper case letter at least 10mm high with the orientation shown in the example; and
 - (e) it is fixed to the number plates so the letter marked on the label is in an upright position; and

- (f) it does not wholly or partly obscure the characters on the number plates.

Example of a label for a hydrogen-powered vehicle—



- (3) In this section—

hydrogen-powered vehicle means a vehicle—

- (a) powered by a hydrogen fuel system; and
(b) that has 1 or more hydrogen fuel containers fitted to the vehicle for the system.

144B Electric-powered vehicles

- (1) An electric-powered vehicle built, or a vehicle modified to be an electric-powered vehicle, after 1 January 2019 must have fixed conspicuously to its front and rear number plates a label that complies with subsection (2).
- (2) For subsection (1), a label complies with this subsection if—
- (a) it is affixed to a plate made of metal of at least 1mm thick; and
- (b) the label, and the plate to which it is affixed, is triangular in shape with sides of 30mm in length; and
- (c) it has a blue surface complying with class 2 of AS 1906.1 (Australian Standard for retroreflective materials and devices for road traffic control purposes—retroreflective sheeting); and
- (d) it is marked ‘EV’ in white upper case letters at least 8mm high with the orientation shown in the example; and

- (e) it is fixed to the number plates so the letters on the label are in an upright position; and
- (f) it does not wholly or partly obscure the characters on the number plates.

Example of a label for an electric-powered vehicle—



- (3) This section does not apply to a hydrogen-powered vehicle mentioned in section 144A even if the vehicle is fitted with an electric motor or traction motor used in conjunction with a hydrogen fuel system for the propulsion of the vehicle.
- (4) In this section—

electric-powered vehicle means a vehicle powered by 1 or more electric motors or traction motors that are—

 - (a) the only propulsion system for the vehicle; or
 - (b) used in conjunction with another propulsion system for the vehicle.

Part 11 Mechanical connections between vehicles

145 General coupling requirements

- (1) A fifth wheel coupling, the mating parts of a coupling, a kingpin or a towbar must not be used for a load on a vehicle that is more than the manufacturer's load rating for the coupling, mating parts, kingpin or towbar.
- (2) A kingpin must be used only with a fifth wheel coupling that has a corresponding jaw size.

Example—

An adaptor must not to be used to fit a kingpin to a fifth wheel coupling.

- (3) The mating parts of a coupling used to connect a semitrailer to a towing vehicle must not allow the semitrailer to roll to an extent that makes the vehicle unstable.

146 Drawbar couplings

- (1) A coupling for attaching a trailer, other than a semitrailer or pole-type trailer, to a towing vehicle must be built and fitted so that—
 - (a) the coupling is equipped with a positive locking mechanism; and
 - (b) the positive locking mechanism can be released regardless of the angle of the trailer to the towing vehicle.
- (2) If the trailer is in a combination and is not fitted with breakaway brakes in accordance with section 127(2), it must be connected to the towing vehicle by—
 - (a) at least 1 chain, cable or other flexible device; and
 - (b) the coupling required under subsection (1).
- (3) The connection must be built and fitted so that—
 - (a) the trailer is kept in tow if the coupling breaks or accidentally detaches; and
 - (b) normal angular movement of the coupling is permitted without unnecessary slack.
- (4) If practicable, the connection must be built and fitted so that, if the coupling accidentally detaches, the drawbar of the trailer is prevented from hitting the ground.
- (5) For subsections (3) and (4), a connection between a trailer and a towing vehicle includes anything connecting the trailer and the towing vehicle.

Examples of a connection—

- a chain

Schedule 1

- a cable
- a thing fixed to a trailer or vehicle towing trailer to which a chain is attached
- shackles.

Schedule 2 Exempt areas

schedule 4, definition *exempt area*

- 1 The following local government areas—
 - Aurukun
 - Barcoo
 - Boulia
 - Bulloo
 - Burke
 - Carpentaria
 - Cook
 - Croydon
 - Diamantina
 - Doomadgee
 - Etheridge
 - Hope Vale
 - Kowanyama
 - Lockhart River
 - Mapoon
 - Mornington
 - Napranum
 - Northern Peninsula Area
 - Pormpuraaw
 - Quilpie
 - Torres
 - Torres Strait Island
 - Wujal Wujal
- 2 A Queensland island on which there is no AIS or, for a particular type of vehicle, no AIS approved to inspect that type of vehicle
- 3 For a motorbike—an area outside a radius of 50km of an AIS approved to inspect motorbikes
- 4 For a trailer with an ATM of more than 0.75t but not more than 4.5t—an area outside a radius of 50km of an AIS approved to inspect trailers with an ATM of more than 0.75t but not more than 4.5t
- 5 For a vehicle not mentioned in item 2, 3 or 4—in each of the following local government areas, an area that is outside a radius of 50km of an AIS approved to inspect the type of vehicle—

Schedule 2

- Balonne
- Barcaldine
- Blackall-Tambo
- Central Highlands
- Charters Towers
- Cloncurry
- Flinders
- Goondiwindi
- Isaac
- Longreach
- Maranoa
- Mareeba
- McKinlay
- Mount Isa
- Murweh
- Paroo
- Richmond
- Tablelands
- Western Downs
- Whitsunday
- Winton
- Woorabinda

Schedule 3 Fees

section 110

	Fee units
1 Inspection of vehicle for issue of safety certificate—	
(a) for a motorbike	58.26
(b) for a light motor vehicle other than a motorbike	90.63
(c) for a trailer with an ATM of more than 0.75t but not more than 4.5t	45.39
2 Inspection of vehicle for issue of certificate of inspection—	
(a) for a bus with a GVM of not more than 4t or a school bus	94.97
(b) for another bus with a GVM of more than 4t	112.08
(c) for another light motor vehicle—	
(i) for inspection by an authorised officer	56.35
(ii) for inspection by an approved examiner	92.23
(d) for another motor vehicle that is a heavy vehicle with a GVM of not more than 16t	129.45
(e) for another motor vehicle that is a heavy vehicle with a GVM of more than 16t	161.97
(f) for a trailer with an ATM of more than 4.5t	73.46
(g) for inspection of a vehicle by an authorised officer requested outside of ordinary business hours—a fee equal to the overtime payable to, and travelling expenses incurred by, the authorised officer for the inspection, in addition to any fees for inspection of the vehicle	

	Fee units
3 Inspection of vehicle under section 36 of the Act	56.35
4 Booking fee for inspection of vehicle by authorised officer	32.85
5 Inspection of a light vehicle following the issue of a defect notice—	
(a) if the defect notice was issued because the vehicle was unsafe	103.05
(b) otherwise	50.65
6 Inspection of a heavy vehicle for the purpose of making a decision under the Heavy Vehicle National Law (Queensland), section 87	56.35
7 Inspection of a heavy vehicle required to be produced for inspection under the Heavy Vehicle National Law (Queensland), section 522	56.35
8 Inspection of a heavy vehicle following the issue of a major defect notice under the Heavy Vehicle National Law (Queensland), section 526(2)(a)	103.05
9 Inspection of a heavy vehicle following the issue of a minor defect notice under the Heavy Vehicle National Law (Queensland), section 526(2)(b)	50.65
10 Surveying plans for approval under section 23 of a modification of a light vehicle	100.45
11 Issuing a replacement inspection certificate or replacement certificate of modification	24.70
12 Copy of approved examiner’s inspection report issued by the chief executive	24.70
13 Supplying book of 50 inspection certificates	85.70
14 Supplying book of 50 certificates of modification	51.95
15 Postage and handling for each package of up to 4 books of inspection certificates or certificates of modification	10.40

Schedule 4 Dictionary

section 4

adopted standard, for schedule 1, see schedule 1, section 3.

ADR, for schedule 1, see schedule 1, section 3.

ADR (definitions and vehicle categories) means the *Vehicle Standard (Australian Design Rule—Definitions and Vehicle Categories) 2005* (Cwlth).

air brake, for schedule 1, see schedule 1, section 3.

Airservices Australia, for schedule 1, see schedule 1, section 3.

Airservices Australia vehicle, for schedule 1, see schedule 1, section 3.

air storage tank, of a vehicle, for schedule 1, see schedule 1, section 3.

AIS see the *Transport Operations (Road Use Management—Accreditation and Other Provisions) Regulation 2015*, schedule 7.

approval, in relation to an approved modification, means the chief executive's approval of the modification under section 23.

approved modification means a modification of a light vehicle that has been approved by the chief executive under section 23.

approved examiner see the *Transport Operations (Road Use Management—Accreditation and Other Provisions) Regulation 2015*, schedule 7.

approved person see the *Transport Operations (Road Use Management—Accreditation and Other Provisions) Regulation 2015*, schedule 7.

ATM (aggregate trailer mass), for a trailer—

- (a) means the maximum mass, specified by the manufacturer, for the trailer when it is loaded; and
- (b) includes the mass imposed on the towing vehicle when the towing vehicle and trailer are on a horizontal surface.

Australian Border Force vehicle, for schedule 1, see schedule 1, section 3.

axle means 1 or more shafts, positioned in a line across a vehicle, on which 1 or more wheels intended to support the vehicle turn.

axle group, for schedule 1, see schedule 1, section 3.

booked hire vehicle see the *Transport Operations (Passenger Transport) Act 1994*, schedule 3.

braking system, for schedule 1, see schedule 1, section 3.

British Standard, for schedule 1, see schedule 1, section 3.

British Standards Institution, for schedule 1, see schedule 1, section 3.

bus means a motor vehicle built mainly to carry people that seats 10 or more adults.

car, for schedule 1, see schedule 1, section 3.

centre line, for an axle or an axle group, for schedule 1, see schedule 1, section 3.

certificate of inspection see section 66(1).

certificate of modification, for a modified vehicle, means a certificate in the approved form that records that the modification of the vehicle has been inspected and found to comply with the light vehicle standards (modification).

certified modification means a modification of a vehicle for which a certificate of modification has been issued under section 26.

certified to ADR 83/00, for schedule 1, part 9, division 3, see schedule 1, section 136.

chassis, for a vehicle with a frame and body that are a unit, includes—

- (a) the cab and cowl of the vehicle; and
- (b) a part of the body of the vehicle that is a structural support.

code S13 modification, of a heavy bus, see section 25(b).

COI database means an information system for certificates of inspection issued by authorised officers made available by the chief executive.

COI vehicle see section 70.

compliance plate means a plate authorised to be placed on a vehicle, or taken to have been placed on a vehicle, under—

- (a) the repealed *Motor Vehicle Standards Act 1989* (Cwlth); or
- (b) the *Road Vehicle Standards (Consequential and Transitional Provisions) Act 2018* (Cwlth), schedule 3, part 3.

compliant, for a modification of a light vehicle, see section 17.

component, of a light vehicle, includes—

- (a) a part fitted, or required under the light vehicle standards to be fitted, to the vehicle; and
- (b) a component of the vehicle necessary for the control of emissions of gas, particles or noise; and
- (c) a label required, under the light vehicle standards, to be fitted to a number plate attached to the vehicle.

converter dolly, for schedule 1, see schedule 1, section 3.

daylight, for schedule 1, see schedule 1, section 3.

dealer means—

- (a) in relation to a trailer—a person whose business is, or includes, the sale of used trailers; or

- (b) otherwise—a motor dealer under the *Motor Dealers and Chattel Auctioneers Act 2014*.

defective—

- (a) for a light vehicle—see section 7; or
- (b) for a heavy vehicle—means the vehicle is a defective heavy vehicle under the Heavy Vehicle National Law (Queensland), section 525.

defect notice see section 9(2).

diesel engine, for schedule 1, see schedule 1, section 3.

disposal, of a vehicle, includes delivery of possession of the vehicle under a barter, gift, hire-purchase agreement, lease or sale, but does not include—

- (a) disposal of the vehicle to a bailee for alteration, repair, renovation or garaging of the vehicle or a similar purpose that does not involve use of the vehicle for the bailee's benefit; or
- (b) disposal of the vehicle to a person entitled to the vehicle as beneficiary in an estate; or
- (c) passing, or apparently passing, possession of the vehicle, from 1 body corporate (the **first body corporate**) to another body corporate (the **second body corporate**) because—
- (i) the name of the first body corporate is changed by law to the name of the second body corporate; or
- (ii) the second body corporate is a reconstruction of the first body corporate, or the result of an amalgamation of the first body corporate and 1 or more other bodies corporate, under a law; or
- (iii) the second body corporate is a holding company or subsidiary company of the first body corporate; or
- (d) disposal as a result of the reconstitution of a partnership; or
- (e) disposal of a vehicle, other than a COI vehicle, by a person to the person's spouse; or

- (f) disposal of a vehicle, other than a COI vehicle, under any of the following instruments—
- (i) an agreement registered or approved under the *Family Law Act 1975* (Cwlth);
 - (ii) an order of a court under the *Family Law Act 1975* (Cwlth);
 - (iii) an instrument made after the start of a proceeding for the dissolution or annulment of a marriage;
 - (iv) a recognised agreement under the *Property Law Act 1974*, section 266, to the extent the agreement deals with the property of de facto partners;
 - (v) an order of a court under the *Property Law Act 1974*, part 19, to the extent the order deals with the property of de facto partners;
 - (vi) an instrument made under an instrument mentioned in subparagraph (i), (ii) (iv) or (v).

dog trailer, for schedule 1, see schedule 1, section 3.

drawbar, for schedule 1, see schedule 1, section 3.

electronic system means the electronic system for issuing inspection certificates made available by the chief executive.

emergency brake, for schedule 1, see schedule 1, section 3.

emergency vehicle, for schedule 1, see schedule 1, section 3.

exempt area means—

- (a) an area mentioned in schedule 2, item 1; and
- (b) for a vehicle that is not a COI vehicle—includes an area mentioned in schedule 2, item 2, 3, 4 or 5.

exempted provision, for a safe movement approval, for part 5, see section 49.

exhaust system means a system fitted to a light vehicle through which exhaust from the vehicle's engine passes.

fifth wheel coupling, for schedule 1, see schedule 1, section 3.

fitted, for component of a light vehicle, means—

- (a) if the light vehicle standards prescribe a requirement for fitting the component to the vehicle—the component is fitted to the vehicle in accordance with the standards; or
- (b) otherwise—the component is fitted securely to the vehicle.

front fog light, for schedule 1, see schedule 1, section 3.

GCM (gross combination mass)—

- 1 The *GCM* of a motor vehicle is the maximum loaded mass for the motor vehicle and any vehicles it may lawfully tow—
 - (a) stated for the motor vehicle in the RAV; or
 - (b) if the maximum loaded mass is not stated in the way mentioned in paragraph (a)—
 - (i) stated on the motor vehicle’s compliance plate; or
 - (ii) if the motor vehicle does not have a compliance plate or the maximum loaded mass is not stated on the compliance plate or is illegible—
 - (A) stated by the motor vehicle’s manufacturer in another place; or
 - (B) if the motor vehicle’s manufacturer can not be identified—stated by the registration authority for the motor vehicle.
- 2 However, if a motor vehicle has been modified, the *GCM* of the motor vehicle is the maximum loaded mass for the motor vehicle and any vehicles it may lawfully tow—
 - (a) stated on the relevant certificate or relevant plate for the modification; or

- (b) if the maximum loaded mass is not stated in the way mentioned in paragraph (a)—stated by the registration authority for the motor vehicle; or
- (c) if the maximum loaded mass is not stated in any of the ways mentioned in paragraph (a) or (b)—applying to the motor vehicle under paragraph 1.

goods vehicle, for schedule 1, see schedule 1, section 3.

GTM, for schedule 1, see schedule 1, section 3.

heavy bus means a bus with a gross vehicle mass of more than 5t.

high-beam, for schedule 1, see schedule 1, section 3.

HVNL certificate, for a modification of a heavy vehicle, means a certificate approving the modification given under the Heavy Vehicle National Law (Queensland), section 86(2)(a) or 87(3)(a) or a corresponding law.

HVNL plate, for a modification of a heavy vehicle, means a plate or label relating to the modification fitted or affixed to the vehicle under the Heavy Vehicle National Law (Queensland), section 86(2)(b) or 87(3)(b) or a corresponding law.

identification plate has the meaning given by the repealed *Motor Vehicle Standards Act 1989* (Cwlth).

information includes a document.

inspection certificate see section 65.

inspection report see section 86(2)(a).

interstate modification means a modification of a light vehicle made in another State that—

- (a) is certified, however called, under a corresponding law for part 3, division 3; or
- (b) would, had the modification been made in Queensland, be a modification—
 - (i) required to be certified under the light vehicle standards (modification); or

(ii) mentioned in section 21.

left, for schedule 1, see schedule 1, section 3.

light combination means a combination that is a light vehicle.

light motor vehicle means a motor vehicle that is a light vehicle.

light trailer means a trailer that is a light vehicle.

light vehicle see section 5.

light vehicle standards see section 6(2).

light vehicle standards (modification) see section 6(4).

light vehicle standards (safety inspection) see section 6(5).

limousine see the *Transport Operations (Passenger Transport) Act 1994*, schedule 3.

load see section 30.

loaded mass, for a light vehicle, means the vehicle's mass together with the mass of the vehicle's load that is transmitted to the ground.

low-beam, for schedule 1, see schedule 1, section 3.

maintenance management accreditation see the Heavy Vehicle National Law (Queensland), section 5.

maintenance management system see the Heavy Vehicle National Law (Queensland), section 457 or a corresponding law.

mass requirement, for a light vehicle, see section 31.

miscellaneous vehicle means—

- (a) an aircraft; or
- (b) a motorised mobility device; or
- (c) a power-assisted pedal cycle as defined under the ADR (definitions and vehicle categories); or
- (d) a personal mobility device; or
- (e) a vehicle—

- (i) designed to be controlled by a person walking next to it; or
- (ii) drawn by animal power; or
- (iii) propelled, or designed to be propelled, by human power; or
- (iv) propelled by 1 or more motors with a combined maximum power output of not more than 200W.

modification plate, for a modification of a light vehicle, means a plate in the approved form that is stamped or engraved with the details of the modification of the vehicle.

modified heavy vehicle means a heavy vehicle that has a modification under the Heavy Vehicle National Law (Queensland), part 3.3.

modify, a light vehicle, means alter the vehicle in a way that is not in accordance with—

- (a) if there is the manufacturer's specification for the vehicle—the manufacturer's specification; or
- (b) otherwise—the original design for the vehicle.

Examples of altering a vehicle—

- adding a component not stated in the manufacturer's specifications or original design for the vehicle to the vehicle
- removing a component stated in the manufacturer's specifications or original design for the vehicle from the vehicle
- altering a component in a way other than as stated in the manufacturer's specifications or original design for the vehicle

moped, for schedule 1, see schedule 1, section 3.

motorbike, for schedule 1, see schedule 1, section 3.

motortrike, for schedule 1, see schedule 1, section 3.

mudguard, for schedule 1, see schedule 1, section 3.

National Heavy Vehicle Inspection Manual means the document titled 'National Heavy Vehicle Inspection Manual' produced by the Regulator under the Heavy Vehicle National Law and published on the Regulator's website.

National Transport Commission means the National Transport Commission established under the *National Transport Commission Act 2003* (Cwlth), section 5.

nearer side of the vehicle, for schedule 1, see schedule 1, section 3.

original design, for a light vehicle—

- (a) means the design of the vehicle when the vehicle is built and before any alteration is made to the vehicle; and
- (b) includes the manufacturer's design for a component of the vehicle before an alteration is made to the component.

parking brake, for schedule 1, see schedule 1, section 3.

point of articulation, for schedule 1, see schedule 1, section 3.

pole-type trailer means a light trailer—

- (a) attached to a towing vehicle by a pole or an attachment fitted to the pole; and
- (b) ordinarily used for transporting loads, for example, logs, pipes, structural members, or other long objects, that can generally support themselves like beams between supports.

Example of a pole-type trailer—

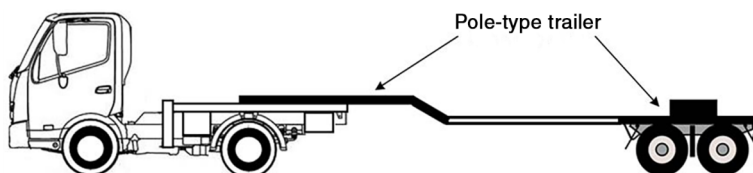

police vehicle, for schedule 1, see schedule 1, section 3.

proprietor, see the *Transport Operations (Road Use Management—Accreditation and Other Provisions) Regulation 2015*, schedule 7.

public passenger service see the *Transport Operations (Passenger Transport) Act 1994*, schedule 3.

Queensland Light Vehicle Inspection Manual means the document titled ‘Queensland Light Vehicle Inspection Manual’ produced by the department and published on the department’s website.

Queensland Road Vehicle Modification Handbook means the document titled ‘Queensland Road Vehicle Modification Handbook’ produced by the department and published on the department’s website.

RAV means the Register of Approved Vehicles under the *Road Vehicle Standards Act 2018* (Cwlth).

rear fog light, for schedule 1, see schedule 1, section 102(4).

rear overhang, of a vehicle, for schedule 1, see schedule 1, section 60(1).

rear overhang line, of a vehicle, for schedule 1, see schedule 1, see section 60(2), (3) and (4).

registration authority, for a vehicle, means the authority responsible for registering vehicles in the State in which the vehicle is, or is required to be, registered.

relevant certificate, for a modification of a light vehicle, means—

- (a) a certificate of modification for the modification; or
- (b) a certificate approving the modification given under a corresponding law to section 26(2)(a).

relevant plate, for a modification of a light vehicle, means—

- (a) a modification plate for the modification; or
- (b) a plate relating to the modification attached to the vehicle under a corresponding law to section 26(2)(b).

repeater horn, for schedule 1, see schedule 1, section 3.

replacement inspection certificate see section 94.

right, for schedule 1, see schedule 1, section 3.

safe movement approval see section 49.

safe movement guideline see section 53(1).

safe movement permit see section 54.

safety certificate see section 67(1).

school bus means a bus while it is being used exclusively for the carriage of school children to or from a school.

second edition ADR, for schedule 1, see schedule 1, section 3.

service brake, for a vehicle, for schedule 1, see schedule 1, section 3.

side marker light, for schedule 1, see schedule 1, section 3.

single axle, for schedule 1, see schedule 1, section 3.

single axle group, for schedule 1, see schedule 1, section 3.

street rod vehicle, for schedule 1, see schedule 1, section 3.

tandem axle group, for schedule 1, see schedule 1, section 3.

taxi see the *Transport Operations (Passenger Transport) Act 1994*, schedule 3.

third edition ADR, for schedule 1, see schedule 1, section 3.

towing vehicle, for a trailer or combination, means the vehicle towing the trailer or combination.

transport enforcement vehicle, for schedule 1, see schedule 1, section 3.

tri-axle group, for schedule 1, see schedule 1, section 3.

turntable, for schedule 1, see schedule 1, section 3.

unique number, for an inspection certificate for a vehicle, means the unique number that identifies the certificate in the COI database or electronic system.

vacuum brakes, for schedule 1, see schedule 1, section 3.

vacuum storage tank, for a vehicle, for schedule 1, see schedule 1, section 3.

visibility requirements, for a load projecting from a light vehicle, see section 39.

warning light, for schedule 1, see schedule 1, section 3.

yellow, for schedule 1, see schedule 1, section 3.